



Autodesk Inventor Tutorials

by Sean Dotson

www.sdotson.com

sean@sdotson.com

Introduction to 3D Sketches

Latest Revision: 5/06/02

**© 2002 Sean Dotson (sdotson.com)
Inventor is a registered trademark of Autodesk Inc.**

By downloading this document you agreed to the following:

Your use of this material is for information purposes only. You agree not to distribute, publish, transmit, modify, display or create derivative works from or exploit the contents of this document in any way. Any other use, including the reproduction, modification, distribution, transmission, republication, display, or performance, of the content on this site is strictly prohibited.

Another popular request in the Inventor NG is how to construct 3D sweeps. This is useful in tubing, piping and wiring applications. If you are going to get very detailed in piping and wire harness design there are add on packages to Inventor that will help simplify this process. But if you just need to route a few hoses or wires, 3D sweeps can help you here. Furthermore you can make these sweep adaptive so that they will change with your base geometry.

We start our example with a simple assembly. While 3D sweep can be constructed in a standalone part environment, to have adaptability you need to work in the assembly environment. Our assembly consists of two parts. One bracket with a hose attachment on each end (the two extruded circles) and a plate in the middle with a hole cut through. The goal of this tutorial is to show the user how to connect the two hose attachment together with a 3D sweep that passes through the hole, no matter to where the hole (or hose attachments) are moved. (see Figure 1)

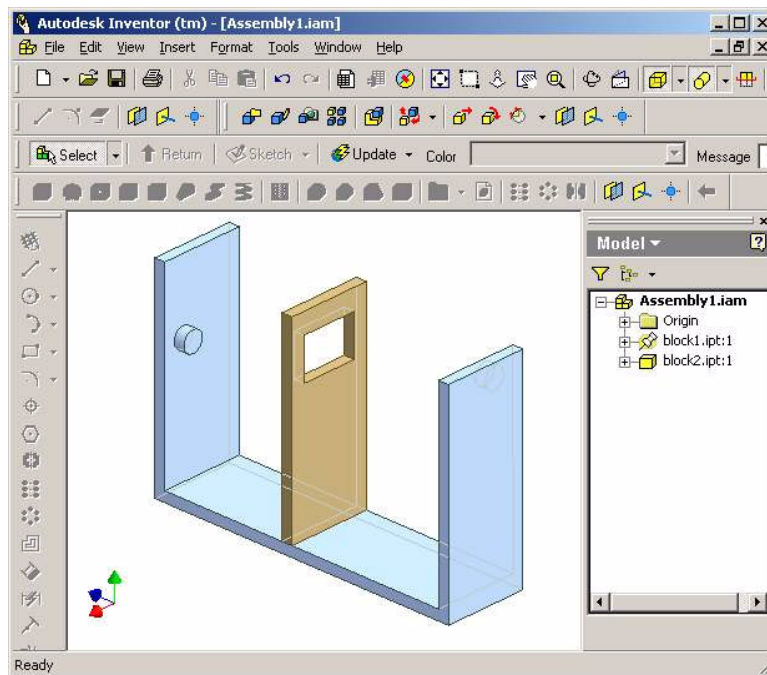

Figure 1 – Assembly

At this point we want to create the part that will be our tubing. Select the “Create Component” button from the assembly menu. Name the file, select its location and select the template file you want to use. (see Figure 2). Be sure the “Constrain sketch plane to selected plane or face” checkbox is checked. This assures that the part will be constrained to the first face chosen. Hit OK when done. (Note: when you exit this dialogue the parts will likely appear opaque. In this example the opacity was turned off so that the images would appear more clearly)

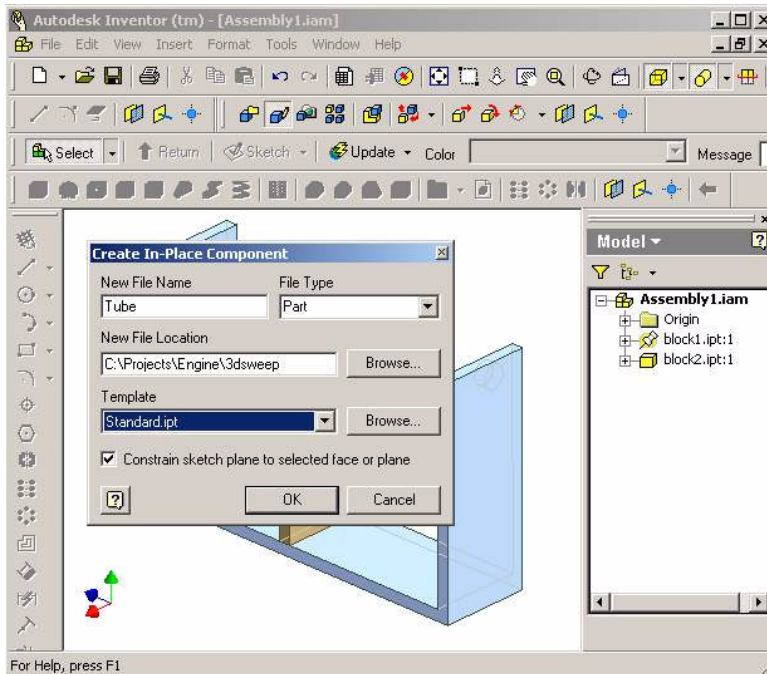

Figure 2 – Create Component Dialogue

You must now choose the face to being the sketch. Choose one of the circular extrusions. This will begin a new 2D sketch. In our example the diameter of the hose is the same as the diameter of the connections so we simply project the geometry of the circle. If the diameters are not the same, simply sketch whatever geometry you wish on this face to be used as a sweep profile. (see Figure 3)

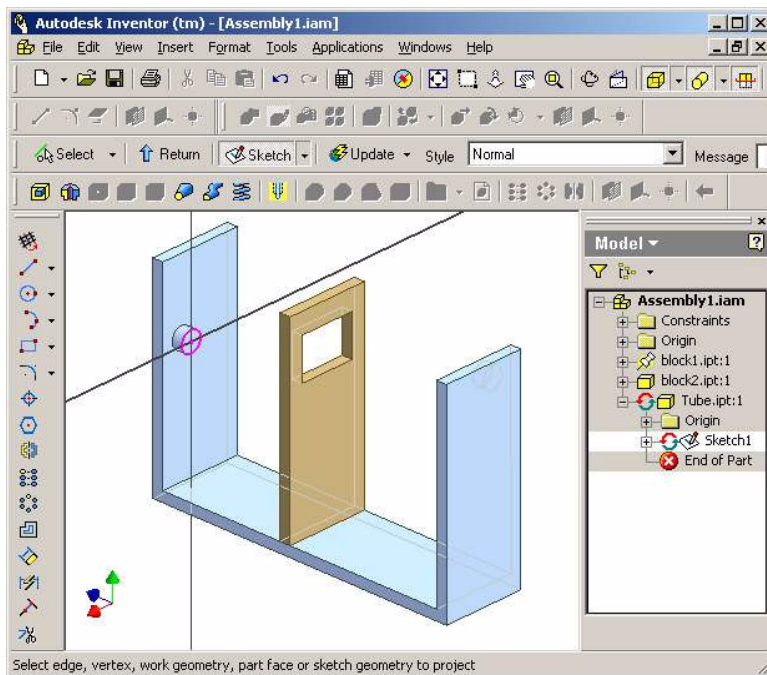

Figure 3 - 2D Sketch on Hose Connection Face

Exit the 2D sketch. We are now ready to begin the 3D sketch. On the Sketch button pull down select 3D sketch.

3D sketches are nothing more than a line in space with 3 degrees of freedom (ignoring any rotational degrees of freedom). They can be controlled by dimensions but these dimensions then “hard-code” the shape of the sweep. This can be useful in some cases (e.g. when you have a bent tube of which you know the geometry and have to design around) but the more useful and robust technique is to use work geometry to control the sweep.

A 3D sweep line can be constructed by following a series of work points. These work points must be defined in space by a plane and an axis, two intersecting axes or three intersecting planes. By constructing a series of workplanes and axes based off existing geometry the user can then place workpoints onto these planes and axes to form a “connect-the-dots” framework for the sketch.

In our example we begin with an axis through the first hose connection. We place a workpoint on the face of the connection and through the workpoint. We then place a work plane a distance off the face of the connection and place another workpoint on this plane and the hose connection axis. This provides us a small “straight” section before leading into the connection. Failure to do this can result in the face of the hose not being planar with the hose connection face when base geometry is changed.

Additional workplane and axes are placed off the hole in the middle of the plate to constrain the work points to flow through the middle of the cutout. Again we provide two planes set off both sides of the middle plate to make sure the hose is straight as it goes through the middle plate.

We continue this logic until we reach the other hose connection where we place another offset workplane and point (for the short straight section) and a workpoint on the face of the connection and an axis running through the middle. (see Figure 4). (Note that the background color was changed to provide contrast of the workpoints)

Now choose the line tool on the 3D sketch toolbar. Creating the sweep path is as simple as connecting the workpoints. Click on the first workpoint, then the next, then the next etc. until complete. Inventor will automatically provide radii in the intersections of non planar sections of line. These can be changed (as shown in the example) to whatever is required. Note that the first radius is a controlling dimension in that all of the following radii are parametrically referenced to this dimension. Changing the first dimension will change them all. If the second or third dimension requires editing, change that particular dimensions. (see Figure 5)

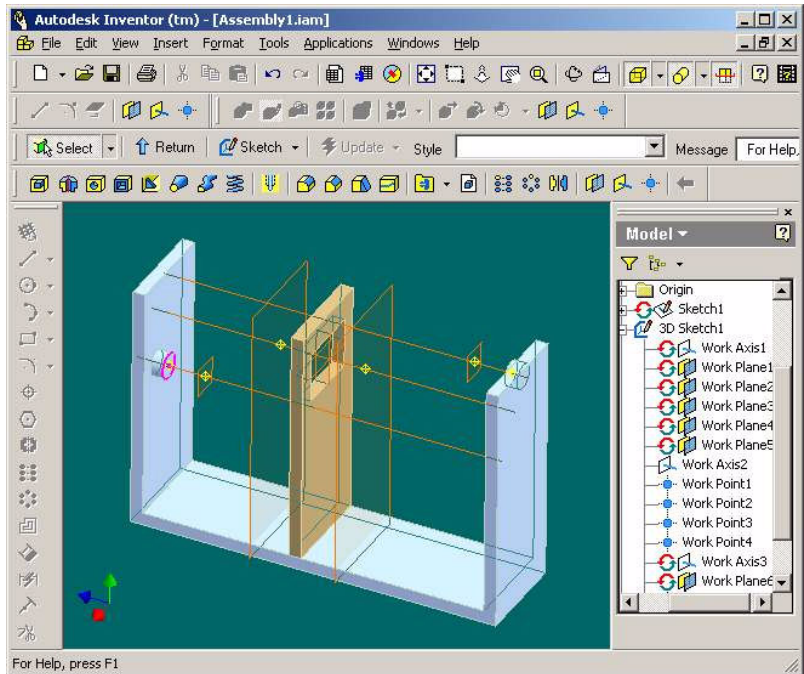

Figure 4 – Workpoints, Planes and Axes

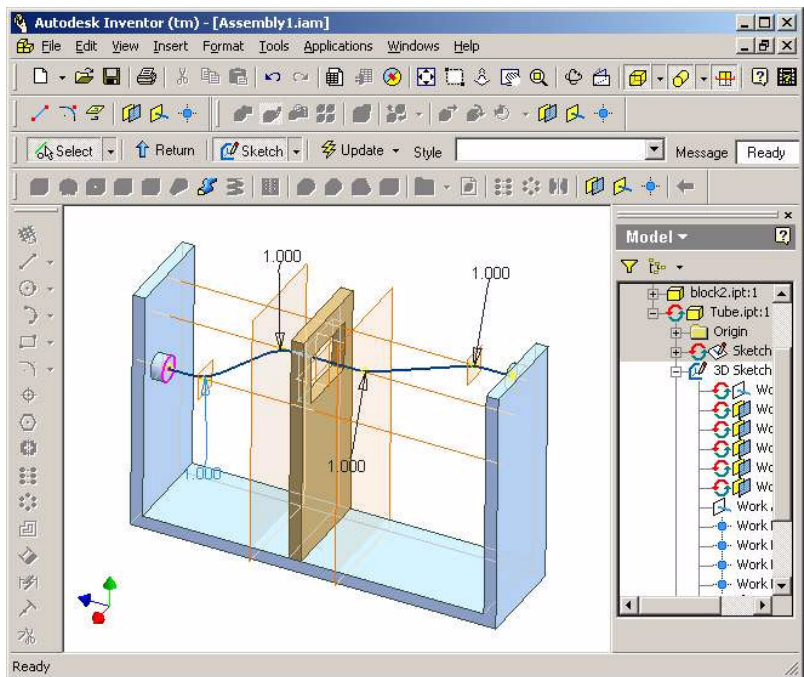

Figure 5 – 3D Sketch completed

The next step in constructing the tube is the actual sweep. While still in the edit part mode choose the sweep command. In this command you will be asked to choose the profile to be swept (the 2D sketch) and the path to follow (the 3D sketch). (see Figure 6)

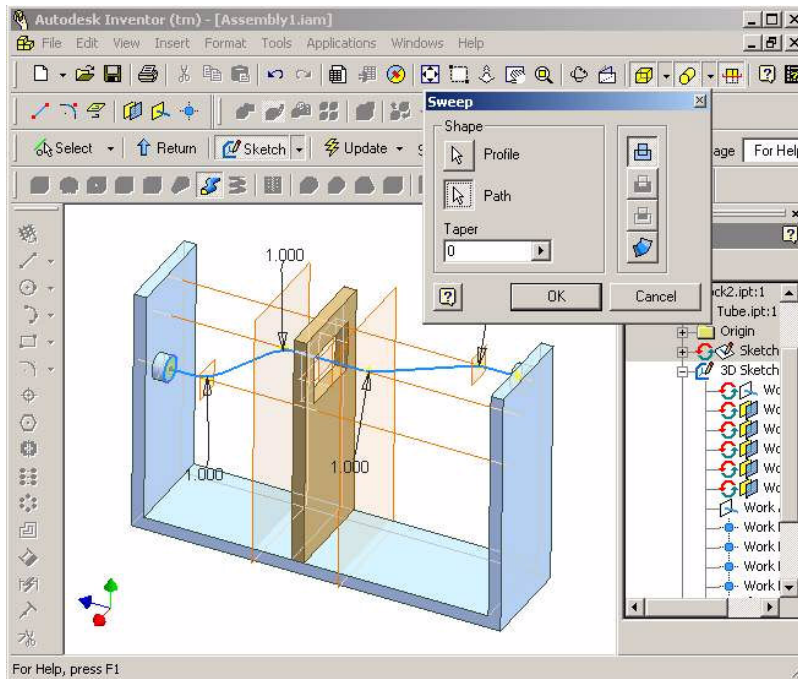

Figure 6 - 3D Sweep Dialogue

Once OK is chosen the sweep will be generated. The tube connects the two hose connections together while passing through the center of the cutout. (see Figure 7)

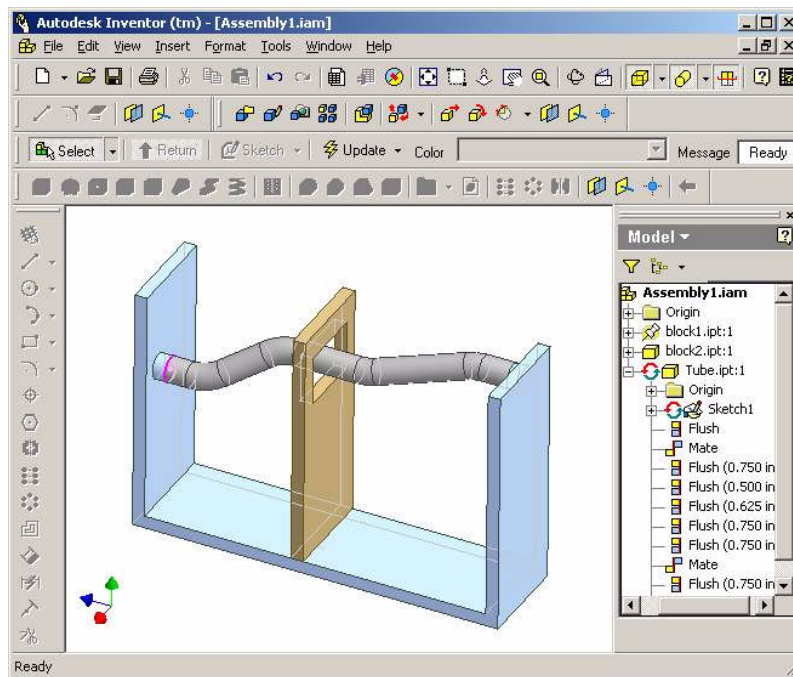

Figure 7 - Completed Sweep

To test the adaptivity of the tube, open the middle block part model and edit the position of the cutout. Save then return to the assembly and update. The hose should have followed the position of the cutout. (see Figure 8) Now open the blue channel and move the positions of the hose connections. Save the file and update the assembly. Again the hose should follow the position of the hose connections. (see Figure 9)

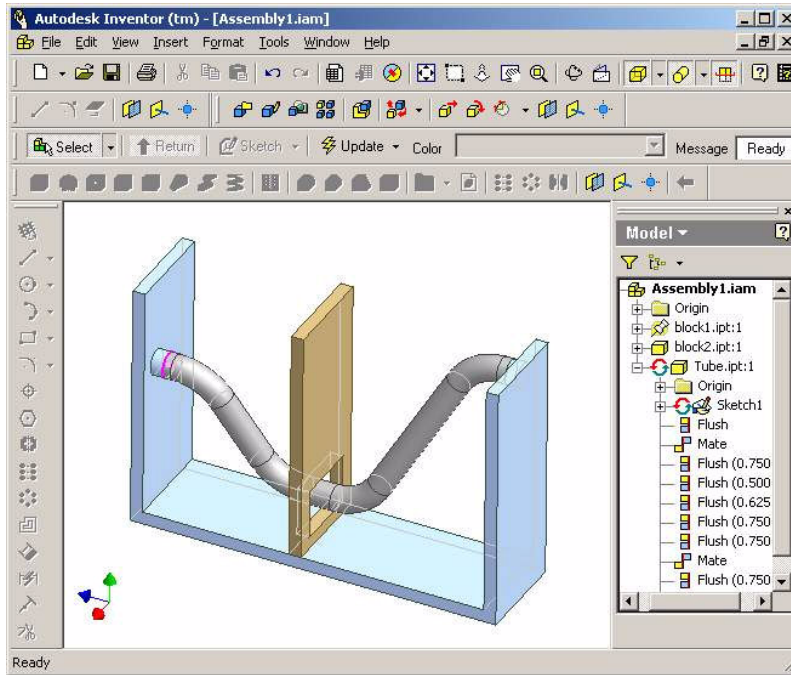

Figure 8 - Moving the Cutout Changes Hose Geometry

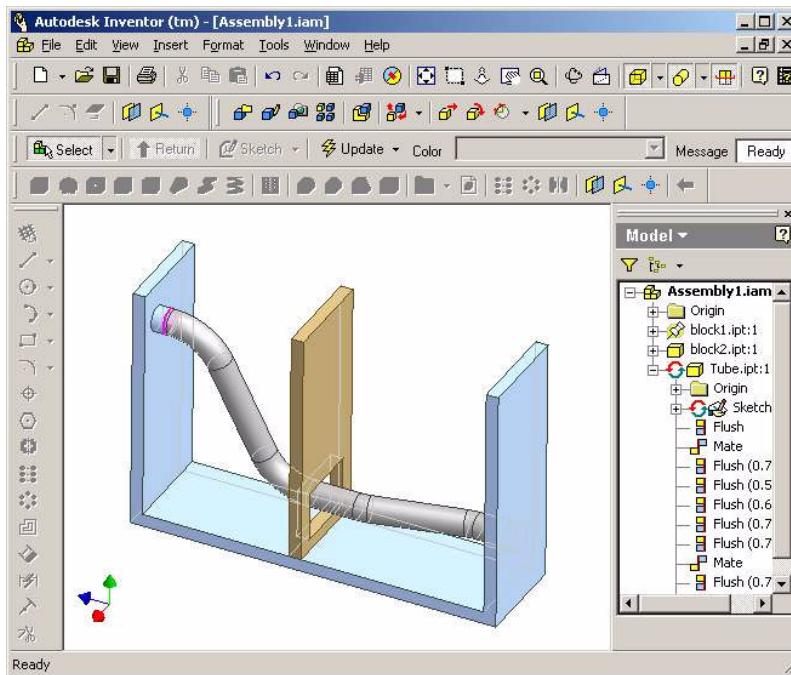

Figure 9 - Moving the Hose Connections Changes Hose Geometry

It is usually a good idea to only change one part at a time and then update the assembly. Changing multiple parts at once can cause some instability in the 3D sweep.

Another limitation of 3D sweeps is the fact that some forethought must be put into how the planes and points are constructed. A change to geometry that will force a radius to go beyond zero or infinity will result in errors in the tubing. This generally happens when the radii and the path are too small for the profile to be swept without the profile “folding in” on itself. Changing the radii generally clears up the error.

Another good resource for 3D sketch techniques is at Drew’s Inventor Tips & Tricks page. It can be found at <http://www.mymcad.com>. Click on Inventor at the top of the page then Inventor Tips and Tricks. The tip is #1012. A direct link to the page is http://www.mymcad.com/iv_tipstricks_answer1012.html but I would suggest looking at the main page as there is a wealth of information there.

While this tutorial is a basic lesson in 3D sweeps the author hopes that you will take the opportunity to experiment with these techniques. If you find a better or faster way to do any of these steps feel free to send me some comments.