

RENOLD

SECTION 3

DESIGNER GUIDE SPECIFICATION GUIDELINES

Renold Chain Designer Guide

3

Development of Early Roller/Bush Chain

As the industrial revolution gained pace, the need for higher performance chain ensured that the product did not stand still. A quick look at the 1880 patent would give the impression that there is no difference between it and modern chain.

In concept, this is true. However, early chain performance was very much constrained by design knowledge, material sophistication and production processes. For example, in order to achieve a close tolerance on round parts, Hans Renold also pioneered centreless grinding and at one time had a whole section devoted to grinding cold drawn bar to size before further processing.

The shortcomings of available technology meant that, compared with modern chain, there were low strength to weight ratios, erratic pitch control, poor engagement characteristics and a tendency toward point loading, causing high bearing pressures, wear and failure. The ever increasing number of applications for chain resulted in a continuous refinement of our production processes and the introduction of heat treatment, improving Renold Chain to meet these new and arduous demands.

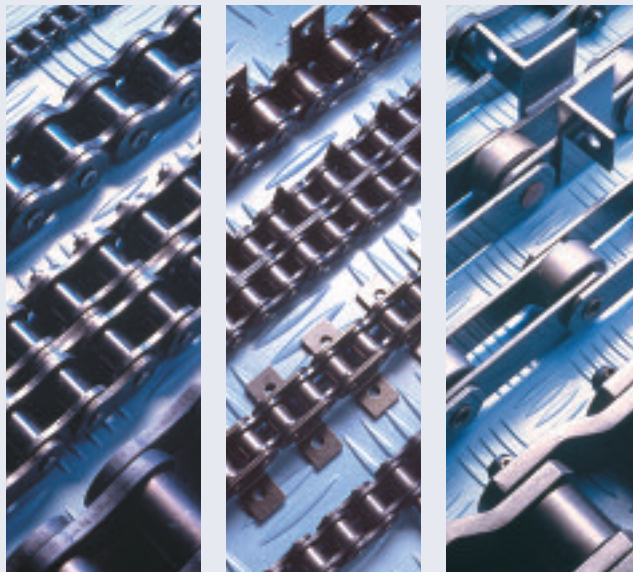

Modern Chain

There is today a very wide range of chain products available. Some of these are special low volume products, for example nuclear waste handling chain. Other high volume products such as motorcycle chain are an offshoot of one of the key groups shown below.

At the top level of the chain groups, conveyor chain is perhaps the most difficult to compartmentalize, since most types of chain can be used to convey. There is, however, a range of so called conveyor chain products typified by its long pitch, large roller diameter and emphasis on tensile strength rather than fatigue life.

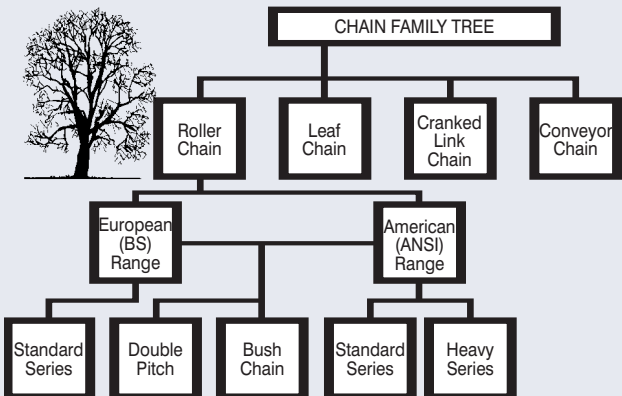

Cranked link chain, like conveyor chain, is intended to run only at low speeds, since the presence of a cranked plate will reduce fatigue life. This chain tends to be used in conveying applications where harsh environmental conditions prevail, in mineral excavation for example.

Leaf chain is similar in construction to the old Galle chain, except that plates are interleaved in various configurations right across the width of the pin. This means that there is no way of providing sprocket engagement and the chain can only be used to transmit force through suitably anchored ends. Chains are guided around simple plain pulleys. Perhaps the best example of the use of leaf chain is in the lifting mechanism of a fork lift truck.

This leaves the most important group of chain, the European and American series of transmission chain. The European (from the old British Standard) range, grew out of the early pioneering work of Hans Renold, as mentioned above, and the size of components through the range therefore reflected a growing understanding of chain design and probably was influenced by the availability of stock material sizes. The American or ANSI range, which came later, has a clear mathematical theme, whereby the sizes of components are calculated in accordance with expressions now quoted in the ANSI standard B29.1. It should also be mentioned here that the ANSI range of chain is shadowed by a range of similar chains, but using the side plate material from the chain of the next highest size. This results in a range of chains with higher fatigue life but not necessarily higher tensile strength, since the pin diameters are unchanged.

Both European and ANSI ranges of chain are available in double pitch and bush chain forms. Double pitch is primarily another form of conveyor chain using the round parts from a standard chain, but having twice the pitch.

Bush chain is simply roller chain without a roller and is also the only design configuration possible on very small pitch chain, such as 4mm and ANSI 25 or 1/4 inch pitch. Bush chain is used for lightly loaded applications or those requiring only direct pull.

Modern chain has features incorporated which enable demanding applications to be tackled with ease. These include high wear and fatigue resistance and transmission efficiency of around 98%.

Chain is also now manufactured in multiple strands joined together by a common pin, giving more scope for increased power transmission in restricted space. The range of products now available with alternative materials, special coatings, endless varieties of attachments, hollow bearing pins and anti-backbend, to name just a few, give scope for the widest portfolio of design solutions imaginable.

Together with improvements to factory applied greases and better understanding of applicational techniques, designers can now specify transmission chain with confidence.

Chain Performance

Renold Chain products that are dimensionally in line with the ISO standard far exceed the stated ISO minimum tensile strength requirements. However Renold does not consider breaking load to be a key indicator of performance because it ignores the principal factors of wear and fatigue. In these areas, Renold products are designed to produce the best possible results and independent testing proves this.

In this catalogue, where the ISO breaking load is quoted, it should be noted that we are stating that the Renold product conforms to the ISO minimum standard. Independent test results show that the minimum (many companies quote averages) breaking loads were far in excess of the ISO minimum.

Where the quoted breaking load is not described as being the ISO minimum, the product has no relevant ISO standard. In this case, the breaking loads quoted are the minimum guaranteed.

The performance of a chain is governed by a number of key factors. The tensile strength is the most obvious since this is the means by which a chain installation is roughly sized. However, since a chain is constructed from steel, the yield strength of which is around 65% of the ultimate tensile strength, any load above this limit will cause some permanent deformation to take place with consequent rapid failure.

Reference to the s-n curve below shows that at loads below this 65% line, finite life may be expected and at subsequent reductions in load the expected life increases until the fatigue endurance limit is reached at around 8 000 000 operations.

Loads below the endurance limit will result in infinite fatigue life. The

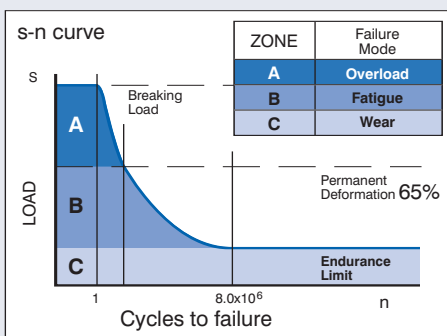

failure mode will then become wear related which is far safer, since a controlled monitor of chain extension can take place at suitable planned intervals. In practice, if a load ratio of tensile strength to maximum working load of 8:1 is chosen, then the endurance limit will not normally be exceeded. Careful consideration of the expected maximum working loads should be given since these are often much higher than the designer may think! It is also a requirement that any passenger lift applications are designed with a safety factor of not less than 10:1.

In most applications the failure mode is designed to be wear and therefore some consideration of how a chain behaves in this mode are shown below.

Examination of the wear characteristics graph below shows that chain tends to wear in three distinct phases. The first phase, shown as 'bedding in', is a very rapid change in chain length associated with components adjusting to the loads imposed on them. The degree of this initial movement will depend to a large extent on the quality of chain used. For example, good component fits, chain pre-loaded at manufacture, plates assembled squarely etc. Renold chain has many features that minimise the degree of bedding in.

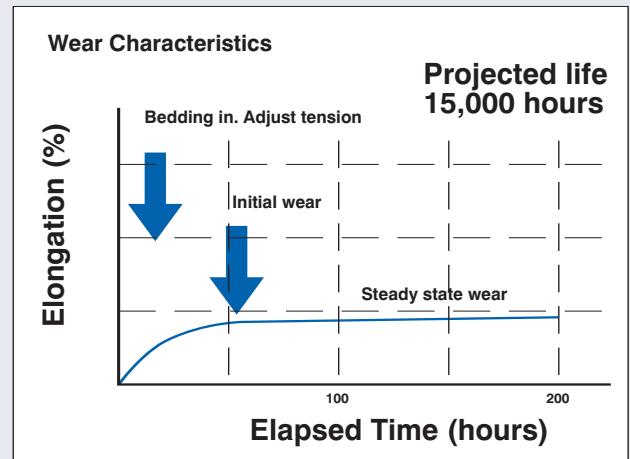

The second phase, shown as 'initial wear', might also be described as secondary 'bedding in'. This is caused firstly by the rapid abrasion of local high spots between the mating surfaces of the pin and bush, and secondly by displacement of material at the bush ends. This is explained more clearly by the inner link assembly diagram shown, where it may be seen that in order to ensure good fatigue life, the bush and plate have a high degree of interference fit resulting in a tendency of the bush ends to collapse inwards slightly. This localised bulge will wear rapidly until the pin bears equally along the length of the bush. Renold limits this effect by introducing special manufacturing techniques. Some manufacturers maintain cylindricity by reducing the interference fit to a very low level. This reduces fatigue performance.

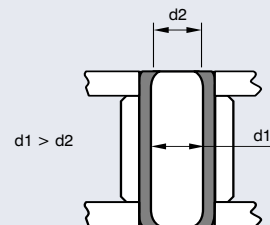

Tendency of bush to collapse at assembly

The final steady state of wear will continue at a very low rate until the chain needs renewal. In a correctly designed and lubricated system, 15 000 hours continuous running should be normal.

Renold Chain Designer Guide

3

The reason that wear takes place at all is demonstrated with reference to the Stribeck diagram below. It may be seen from this that where two mating surfaces are in contact, the coefficient of friction is very high at the point of initial movement, known as static friction. The reason for this is that the surface irregularities of the two bodies are interlocked with little or no separating lubrication layer. As the surface speeds increase, lubricant is drawn between the two surfaces and friction takes place with some surface contact. This condition is known as 'mixed friction'. These two conditions result in material loss over time. With a continuing increase in surface speed, hydrodynamic friction takes place, a condition where there is no metal to metal contact.

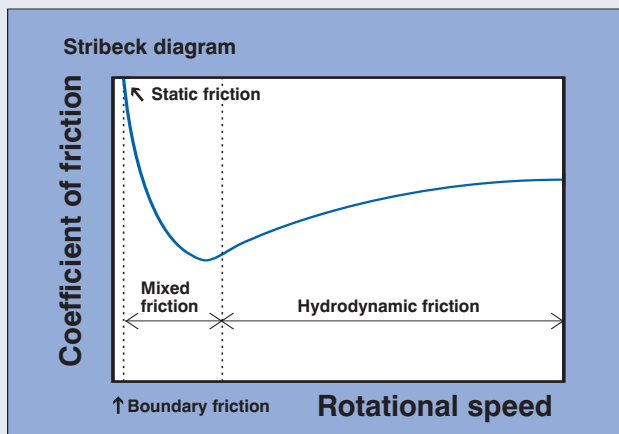

If we consider the action of the mating surfaces of the bush and pin during one cycle of a two sprocket system, it will quickly be realised that these components are stationary with respect to each other during travel from one sprocket to the other, and accelerate rapidly through a very small angle when engaging with the sprocket before coming to rest once more. This means that the pin/bush combination is operating between the static and mixed friction states and that lubrication will therefore be an important aspect of system design.

Wear Factors

As already shown, wear takes place from the friction between the mating of the pin and bush. The rate of wear is primarily determined by the bearing area and the specific pressure on these surfaces. The hardened layers of the pin and bush are eroded in such a way that the chain will become elongated.

ELONGATION may amount to a MAXIMUM of 2% of the nominal length of the chain. Above 2% elongation, there can be problems with the chain riding up and jumping the sprocket teeth.

Elongation should be limited to 1% when:

- A sprocket in the system has 90 teeth or more.
- Perfect synchronization is required.
- Centre distances are greater than recommended and not adjustable.

When the demands of the system become even higher, it is necessary to reduce the allowable percentage elongation further.

Wear depends on the following variables in a drive system:

- **SPEED** - The higher the speed of a system, the higher the frequency of bearing articulations, so accelerating wear.
- **NUMBER OF SPROCKETS** - The more sprockets used in a drive system, the more frequently the bearings articulate.
- **NUMBER OF TEETH** - The fewer the number of teeth in a sprocket, the greater the degree of articulation, the higher the wear.
- **CHAIN LENGTH** - The shorter the length of chain, the more frequently the bearings in the chain will have to operate, the faster wear takes place.
- **LUBRICATION** - As already shown, using the correct lubrication is critical to giving good wear life.

Chain Types

SIMPLEX CHAIN



STANDARD ISO 606 ANSI B29.1

DUPLEX CHAIN



STANDARD ISO 606 ANSI B29.1

TRIPLEX CHAIN

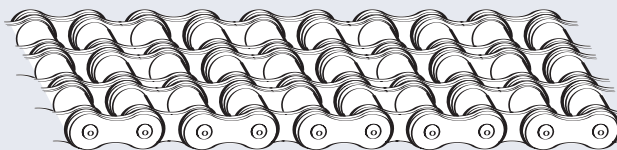

STANDARD ISO 606 ANSI B29.1

As with all engineered products, industry demands that chain be produced to a formal standard. The key transmission chain standards are summarised on page 93.

European Standard

Chains manufactured to the above standards are covered by ISO 606 and DIN 8187. These standards cover 3 versions:

- SIMPLEX
- DUPLEX
- TRIPLEX

The range of pitch sizes can vary between 4mm, (0.158 inch) to 114.3mm, (4.500 inch).

They are characterised by a large pin diameter, especially for the larger pitch sizes. This results in better wear resistance due to the greater bearing area.

The ISO standard has a simple form of part numbering, for example 1/2 inch pitch duplex chain would be 08B-2.

- The first two digits are the pitch size in 1/16's of an inch, therefore 08 = 8/16 or 1/2 inch.
- The letter 'B' indicates European Standard.
- The suffix 2 indicates the number of strands in the chain, in this case a duplex chain.

American Standard

American standard chains are covered by ISO 606, ANSI B29.1 and DIN 8188 and eight versions are covered.

- SIMPLEX, DUPLEX and TRIPLEX as for the European standard chains.
- QUADRUPLEX, 4 strands.
- QUINTUPLEX, 5 strands.
- SEXTUPLEX, 6 strands.
- OCTUPLEX, 8 strands.
- DECUPLEX, 10 strands.

The pitch sizes covered by this standard are 1/4 to 3 inch pitch.

American standard chains have a smaller pin diameter than their European standard equivalent. Wear resistance is therefore reduced when compared with European standard chains with the one exception, 5/8 inch pitch. In this case the pin and bush diameter is larger in an American standard chain.

American standard chains are normally referred to under the ANSI standard numbering system, for example a 1/2 inch pitch duplex chain would be, ANSI 40-2.

The ANSI numbering system works as follows:

- The first number is the pitch size in 1/8 inch, ie 4/8 = 1/2 inch pitch.
- The second number refers to the chain being a roller chain, 0 = roller chain. A 5 replacing the 0 would indicate a bush chain.
- The suffix, as with European standard chain, refers to the number of strands in the chain, that is 2 = duplex chain.

ANSI chain is also available in heavy duty options with thicker plates (H) and through hardened pins (V). An ANSI heavy chain would be specified using these suffixes.

- ie. ANSI 140-2HV Duplex, thick plates, through hardened pin
 ANSI 80H Simplex, thick plates

Range of Application

The transmission chain market worldwide is divided between these two chain standards, based on the economic and historical influences within their regions.

- American standard chain is used primarily in the USA, Canada, Australia, Japan and some Asiatic countries.
- European standard chains dominate in Europe, the British Commonwealth, Africa and Asian countries with a strong British historical involvement.

In Europe around 85% of the total market uses European standard chain. The remaining 15% is American standard chains found on:

- Machinery imported from countries where American standard chain dominates.
- Machinery manufactured in Europe under licence from American dominated markets.

Chain Not Conforming to ISO Standards

There are also Renold manufacturing standards for special or engineered chain which can be split as follows:

1. HIGHER BREAKING LOAD CHAIN - This chain usually has plates that undergo a special treatment, has thicker side plate material and/or pin diameters that slightly deviate from the standards.
2. SPECIAL DIMENSIONS - Some chains can be a mixture of American and European standard dimensions or the inner width and roller diameters vary, such as in motorcycle chains.
3. APPLICATIONAL NEEDS - Special or engineered chain is manufactured for specific applicational use, examples being:

- Stainless steel chain.
- Zinc or nickel plated chain.
- Chain with plastic lubricating bushes.
- Chains with hollow bearing pins.
- Chain that can bend sideways, (SIDEBOW).

In applications requiring a special or engineered chain, we would suggest that you contact our technical sales staff for more information.



Renold Chain Designer Guide

Standards Reference Guide

Transmission Chain Types

	ISO	ANSI	OTHER
Short Pitch Transmission Chain and Sprockets	606	B29.1M	DIN8187 DIN8188
Short Pitch Bush Chains and Sprockets	1395		DIN8154
Double Pitch Roller Chain and Sprockets	1275	B29.3M	DIN8181
Oilfield Chain and Sprockets	606	B29.1M	API Spec 7F
Cycle Chains	9633		
Motorcycle Chains	10190		
Cranked Link Chain and Sprockets	3512	B29.1M	DIN8182

Lifting Chain Types

	ISO	ANSI	OTHER
Leaf Chain, Clevises and Sheaves	4347	B29.8M	DIN8152
Roller Load Chains for Overhead Hoists		B29.24M	

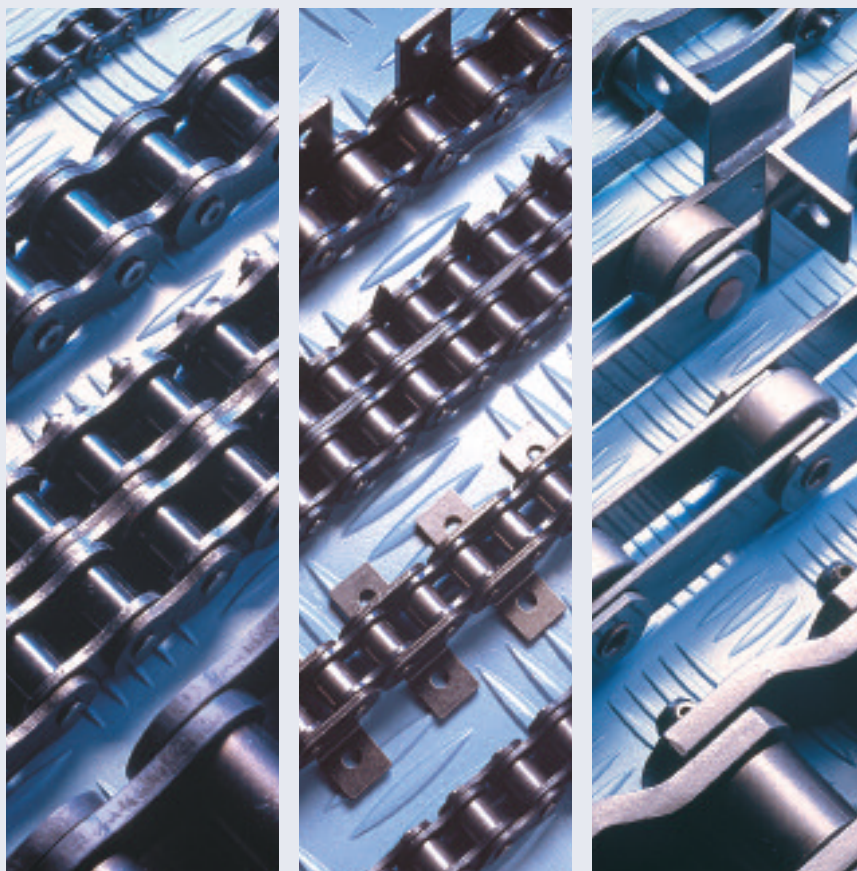

Advantages of Chain Drives

Steel transmission roller chain is made to close tolerances with excellent joint articulation, permitting a smooth efficient flow of power. Any friction between the chain rollers and sprocket teeth is virtually eliminated because the rollers rotate on the outside of the bushes, independent of bearing pin articulation inside the bush. As a result, very little energy is wasted and tests have shown chain to have an efficiency of between 98.4% and 98.9%.

This high level of efficiency, achieved by a standard stock chain drive under the correct conditions of lubrication and installation, is equalled only by gears of the highest standard with teeth ground to very close tolerances.

Roller chain offers a positive, non-slip driving medium. It provides an accurate pitch by pitch positive drive which is essential on synchronised drives such as those to automobile and marine camshafts, packaging and printing machinery. Under conditions of high speed and peak load when efficiency is also required, the roller chain has proved consistently quiet and reliable.

Centre distances between shafts can range from 50mm up to more than 9 metres in a very compact installation envelope. Drives can be engineered so that the sprocket teeth just clear each other or so that a considerable span is traversed by the chain. In this later category, double pitch chain comes into its own.

Roller chain has a certain degree of inherent elasticity and this, plus the cushioning effect of an oil film in the chain joints, provides good shock absorbing properties. In addition, the load distribution between a chain and sprocket takes place over a number of teeth, which assists in reducing wear. When, after lengthy service, it becomes necessary to replace a chain, this is simple and does not normally entail sprocket or bearing removal.

Roller chain minimises loads on the drive motor and driven shaft bearings since no pre-load is required to tension the chain in the static condition.

One chain can drive several shafts simultaneously and in almost any configuration of centre distance or layout. Its adaptability is not limited to driving one or more shafts from a common drive point. It can be used for an infinite variety of devices including reciprocation, racks, cam motions, internal or external gearing, counterbalancing, hoisting or weight suspension. Segmental tooth or 'necklace' chain sprocket rims can be fitted to large diameter drums.

Since there are no elastomeric components involved, chain is tolerant of a wide variety of environmental conditions, including extremes of temperature. Chain is used successfully in such harsh environments as chemical processing, mining, baking, rock drilling and wood processing. Special coatings can easily be applied for further enhancement.

Roller chain can also be fitted with link plate attachments and extended bearing pins etc., which allow them to be used for mechanical handling equipment and the operation of mechanisms. These attachments are detailed in this catalogue.

Roller chain drives are available for ratios up to 9:1 and to transmit up to 520 kw at 550 r.p.m. Beyond this, four matched strands of triplex chain can achieve 3200 kw at 300 r.p.m.

Roller chain does not deteriorate with the passage of time, the only evidence of age being elongation due to wear which normally is gradual and can be accommodated by centre distance adjustment or by an adjustable jockey sprocket. Provided a chain drive is selected correctly, properly installed and maintained, a life of 15000 hours can be expected without chain failure either from fatigue or wear. Where complete reliability and long life are essential, chains can be selected on their assured performance for applications such as hoists for control rods in nuclear reactors and control systems for aircraft.

Chain is a highly standardised product available in accordance with ISO Standards all over the world. It is also totally recyclable and causes no harmful effects to the environment.

Shown below is a simple table comparing the merits of different transmission/lifting media.

Summary of Advantages

FEATURE	GEARS	ROPE	BELT	CHAIN
EFFICIENCY	A	X	B	A
POSITIVE DRIVE	A	X	B	A
CENTRE DISTANCE	C	A	B	A
ELASTICITY	C	A	A	B
WEAR RESISTANCE	A	C	B	A
NO PRE-LOAD	A	C	C	A
MULTIPLE DRIVES	C	X	C	A
HEAT RESISTANT	B	B	C	A
CHEMICAL RESISTANT	B	A	C	A
OIL RESISTANT	A	A	C	A
ADAPTATIONS	C	B	C	A
POWER RANGE	A	X	B	A
EASE OF MAINTENANCE	C	B	B	A
STANDARDISED	C	B	B	A
ENVIRONMENT	A	A	C	A

A = EXCELLENT
C = POOR

B = GOOD
X = NOT APPROPRIATE

NOTE : To achieve the above ratings, different types of belt would be required.

Renold Chain Designer Guide

Chain Selection

The notes given below are general recommendations and should be followed in the selection and installation of a chain drive, in order that satisfactory performance and drive life may be ensured.

Chain Pitch

The Rating Charts (pages 107 and 108) give the alternative sizes of chains that may be used to transmit the load at a given speed. The smallest pitch of a simplex chain should be used, as this normally results in the most economical drive. If the simplex chain does not satisfy the requirements dictated by space limitations, high speed, quietness, or smoothness of running, then consider a smaller pitch of duplex or triplex chain.

When the power requirement at a given speed is beyond the capacity of a single strand of chain, then the use of multistrand drives permits higher powers to be transmitted.

These drives can also be made up from multiples of matched simplex, duplex or triplex ISO chains or in the case of ANSI chain, multiplex chain up to decuplex (10 strands) are available.

Please consult our technical staff for further information.

Maximum Operating Speeds

For normal industrial drives, experience has established a maximum sprocket speed for each pitch of chain. These speeds, which relate to driver sprockets having 17 to 25 teeth inclusive, are given in the graph below; they are applicable only if the method of lubrication provided is in line with recommendations.

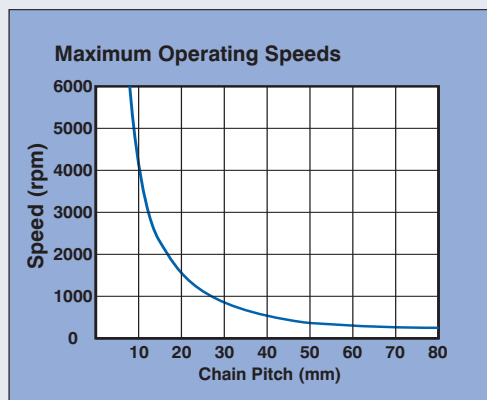

Polygonal Effect

Four important advantages of a chain drive are dependent directly upon the number of teeth in the driver sprocket (Z1).

The advantages are smooth uniform flow of power, quietness of operation, high efficiency and long life, the reason for their dependence being that chain forms a polygon on the sprocket. Thus, when the sprocket speed is constant, the chain speed (due to the many sided shape of its path around the teeth) is subject to a regular cyclic variation. This cyclic variation becomes less marked as the path of the chain tends towards a true circle and in fact, becomes insignificant for most applications as the number of teeth in the driver sprocket exceeds 19.

The effect of this cyclic variation can be shown in the extreme case of a driver sprocket with the absolute minimum number of teeth, i.e. three. In this instance, for each revolution of the sprocket the chain is subjected to a three-phase cycle; each phase being associated with the engagement of a single tooth. As the tooth comes into engagement, for a sixth of a revolution the effective distance, or driving radius from the sprocket centre to the chain is gradually doubled; for the remaining sixth of a revolution, it falls back to its original position. Thus, as the linear speed of the chain is directly related to the effective driving radius of the driver sprocket, the chain speed fluctuates by 50% six times during each revolution of the driver sprocket.

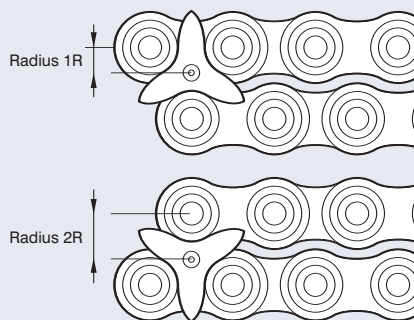

As the graph below shows, the percentage of cyclic speed variation decreases rapidly as more teeth are added. With the driver sprocket of 19 teeth, therefore, this cyclic speed variation is negligible; hence we recommend that driver sprockets used in normal application drives running at medium to maximum speeds, should have not less than 19 teeth.

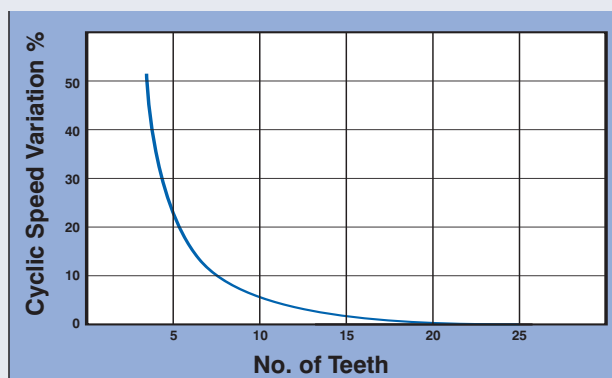

There are, however, applications where space saving is a vital design requirement and the speed/power conditions are such that the smaller numbers of teeth (i.e. below 17) give acceptable performance so that a compact, satisfactory drive is achieved, e.g. office machinery, hand operated drives, mechanisms, etc.

The limiting conditions with steady loading for using small numbers of teeth are:

No. of Teeth	Percentage of Maximum rated speed	Percentage of Maximum rated power
11	20	30
13	30	40
15	50	60
17	80	90

Most drives have an even number of pitches in the chain and by using a driver sprocket with an odd number of teeth, uniform wear distribution over both chain and sprocket teeth is ensured. Even numbers of teeth for both the driver and driven sprockets can be used, but wear distribution on both the sprocket teeth and chain is poor.

Number of Teeth

The maximum number of teeth in any driven sprocket (Z2) should not exceed 114. This limitation is due to the fact that for a given elongation of chain due to wear, the working pitch diameter of the chain on the sprocket increases in relation to the nominal pitch diameter, i.e. the chain assumes a higher position on the sprocket tooth. The allowable safe chain wear is considered to be in the order of 2% elongation over nominal length.

A simple formula for determining how much chain elongation a sprocket can accommodate is $\frac{200}{N}$

expressed as a percentage where N is the number of teeth on the largest sprocket in the drive system.

It is good practice to have the sum of teeth not less than 50 where both the driver and driven sprockets are operated by the same chain, e.g. on a 1:1 ratio drive, both sprockets should have 25 teeth each.

Centre Distance

For optimum wear life, centre distance between two sprockets should normally be within the range 30 to 50 times the chain pitch. On drive proposals with centre distances below 30 pitches or greater than 2m, we would recommend that the drive details are discussed with our technical staff.

The minimum centre distance is sometimes governed by the amount of chain lap on the driver sprocket, our normal recommendation in this circumstance being not less than 6 teeth in engagement with the chain.

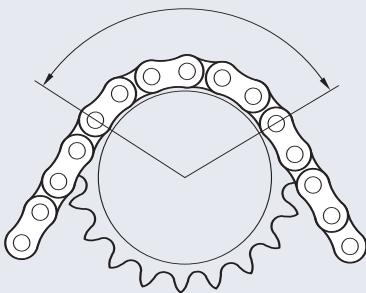

Minimum 6 teeth

The centre distance is also governed by the desirability of using a chain with an even number of pitches to avoid the use of a cranked link, a practice that is not recommended except in special circumstances.

For a drive in the horizontal plane the shortest centre distance possible should be used consonant with recommended chain lap on the driver sprocket.

Formulae for the calculation of chain length and centre distance for two-point drives are given on page 105.

Recommended centre distances for drives are:

Pitch	Inch	3/8	1/2	5/8	3/4	1	1 1/4
	mm	9.525	12.70	15.87	19.05	25.40	31.75
Centre							
Distance mm		450	600	750	900	1000	1200

Pitch	Inch	1 1/2	1 3/4	2	2 1/2	3
	mm	38.1	44.45	50.80	63.50	76.20
Centre						
Distance mm		1350	1500	1700	1800	2000

Lie of Drive

Drives may be arranged to run horizontally, inclined or vertically. In general, the loaded strand of the chain may be uppermost or lowermost as desired. Where the lie of the drive is vertical, or nearly so, it is preferable for the driver sprocket (Z1) to be above the driven sprocket (Z2); however, even with a drive of vertical lie it is quite feasible for the driver sprocket to be lowermost, provided care is taken that correct chain adjustment is maintained at all times.

CENTRES

The centre distance between the axis of two shafts or sprockets

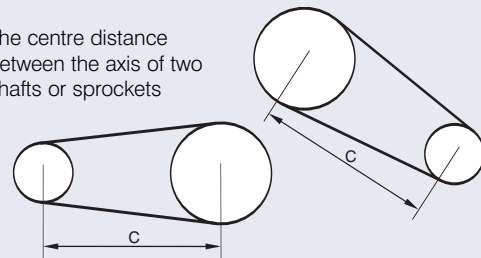

ANGLE

The lie of the drive is given by the angle formed by the line through the shaft centres and a horizontal line.

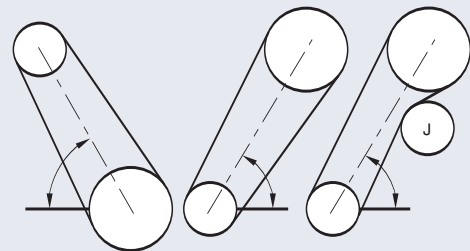

ROTATION

Viewed along the axis of the driven shaft the rotation can be clockwise or anti-clockwise

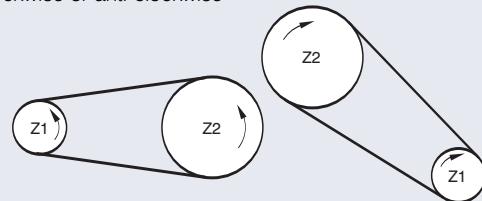

Renold Chain Designer Guide

Drive Layout

One chain can be used for driving a number of shafts and due to the ability of roller chains to gear on either face, individual shafts in the same drive can be made to rotate in the same or opposite directions by arranging the driven sprockets to gear in different faces of the chain. The number of driven sprockets permissible in any one drive depends on the layout.

A selection of possible drive layouts is shown below.

3

DRIVES WITH VARIABLE SHAFT POSITIONS

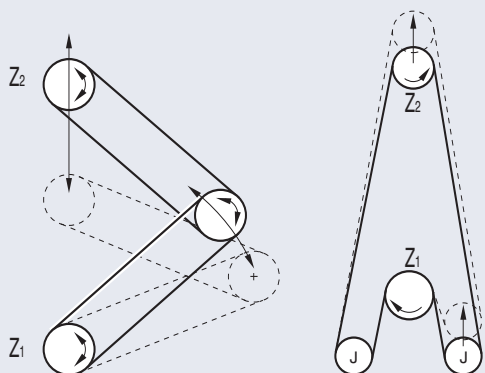

Floating countershaft and floating jockey
 CHAIN LAP - Recommended 120° . Minimum of 90° permissible for sprockets of 27 teeth or over.
 CENTRES - Pitch of chain multiplied by 30 to 50.

DRIVES WITH ABNORMALLY LONG CENTRES

Could incorporate countershafts

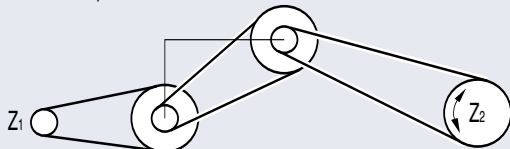

Or supporting jockeys

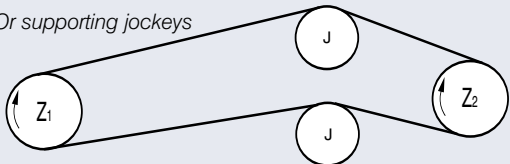

For slow and medium chain speed applications up to 150 metres per minute.

Or supporting guides

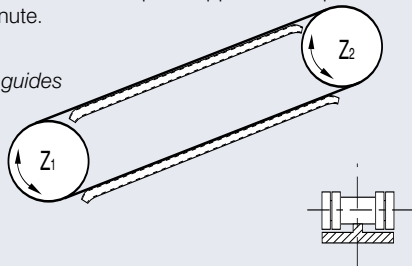

For applications where countershafts or supporting jockeys cannot be employed and where the chain speed does not exceed 60 metres per minute.

MULTI-SHAFT DRIVES

The permissible number of driven shafts will vary according to drive characteristics.

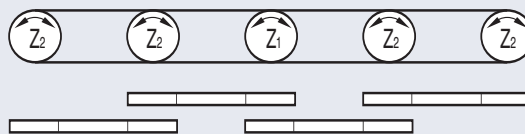

Five sprockets coupled by four simple drives.

Whilst the efficiency of a single stage drive is approximately 98%, where a series of drives are interconnected as in live roller conveyors, the overall efficiency will vary with the number of drives involved. It is necessary in applications of this nature to increase the calculated motor power to allow for this reduced efficiency.

- 4 drives overall efficiency = 94%
- 8 drives overall efficiency = 87%
- 12 drives overall efficiency = 80%

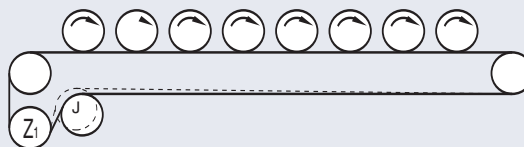

Eight shafts rotated by a single chain with high efficiency but reduced tooth contact.
 The jockey is used to ensure adequate chain lap on the driven sprockets.

HORIZONTAL DRIVES

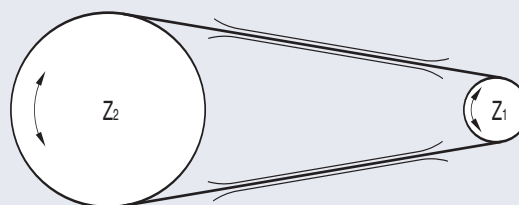
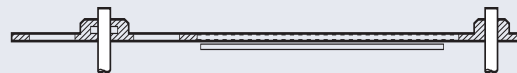

Plan

Two shafts vertically mounted

When centres are long, use guide strips to support chain strands with generous 'lead-in' to ensure smooth entry and exit of chain.

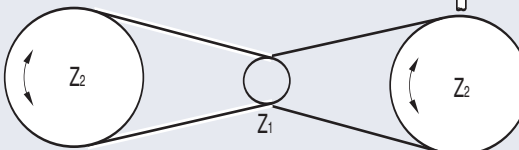
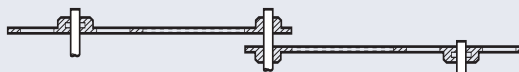

Plan

Three shafts vertically mounted
 CHAIN LAP - Recommended 120° . Minimum of 90° permissible for sprockets of 27 teeth or over.
 CENTRES - Shortest possible.

Introduction

Chain selected using this method will have a minimum life expectancy with proper installation and lubrication of 15000 hours.

Warning

The rating charts page 107 and page 108 exceed the minimum standards and selection of chain using the figures quoted in this section is only valid for RENOLD CHAIN.

Use our interactive Chain Selector on www.renold.com.

Symbols, Terms and Units

- Z1 = Number of teeth on drive sprocket.
- Z2 = Number of teeth on driven sprocket.
- C = Centre distance (mm).
- P = Chain pitch (mm).
- i = Drive ratio.
- L = Chain length (pitches).

In order to select a chain drive the following essential information must be known:

- The power in kilowatts to be transmitted.
- The speed of the driving and driven shafts.
- The characteristics of the drive.
- Centre distance.

From this base information the selection power to be applied to the ratings chart is derived.

1 Select Drive and Ratio

Chart 1 may be used to choose a ratio based on the standard sprocket sizes available. It is best to use an odd number of teeth combined with an even number of chain pitches.

Ideally, chain sprockets with a minimum of 19 teeth should be chosen. If the chain drive operates at high speed or is subjected to impulsive loads, the smaller sprockets should have at least 25 teeth and should be hardened.

It is recommended that chain sprockets should have a maximum of 114 teeth.

Drive ratio can otherwise be calculated using the formula:

$$i = \frac{Z2}{Z1}$$

For large ratio drives, check that the angle of lap on Z1 is not less than 120 degrees.

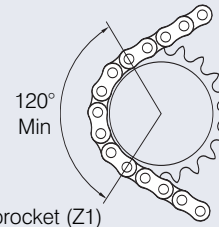

Driver Sprocket (Z1)

SELECT DRIVE RATIO AND SPROCKETS - $\frac{Z2}{Z1}$

Chain Reduction Ratios to One Using Preferred Sprockets

Chart 1

No. of Teeth Driven Sprocket Z2	No. of Teeth Drive Sprocket Z1					
	15	17	19	21	23	25
25	-	-	-	-	-	1.00
38	2.53	2.23	2.00	1.80	1.65	1.52
57	3.80	3.35	3.00	2.71	2.48	2.28
76	5.07	4.47	4.00	3.62	3.30	3.04
95	6.33	5.59	5.00	4.52	4.13	3.80
114	7.60	6.70	6.00	5.43	4.96	4.56

FOR RECOMMENDED CENTRE DISTANCES SEE PAGE 103

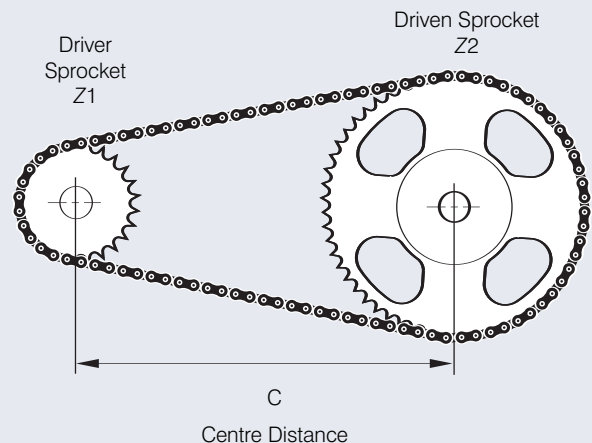

Selection Summary		
1	Select drive ratio and sprockets Z1 = 19 teeth minimum	Page 103
2	Establish selection application factors f1 takes account of dynamic loads Tooth factor f2 (19/Z1)	104
3	Calculate selection power = power x f1 x f2 (kw)	105
4	Select chain drive Use rating charts	105 107-108
5	Calculate chain length using formulae	105
6	Calculate exact centre distance	105
FINALLY	Choose lubrication method	109

Renold Chain Designer Guide

2 Establish Selection Factors

The following factors will be used later on to determine the selection power.

Application Factor f1

Factor f1 takes account of any dynamic overloads depending on the chain operating conditions. The value of factor f1 can be chosen directly or by analogy using chart 2.

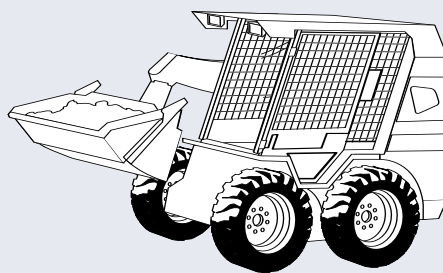

3

Chart 2

DRIVEN MACHINE CHARACTERISTICS		CHARACTERISTICS OF DRIVER		
		SMOOTH RUNNING Electric Motors, Steam and Gas Turbines, Internal Combustion Engines with Hydraulic coupling	SLIGHT SHOCKS Internal Combustion Engines with 6 cyls or more with mechanical Coupling, Electric Motors with frequent starts	MODERATE SHOCKS Internal Combustion Engines with less than 6 cyls, with mechanical coupling
SMOOTH RUNNING	Centrifugal Pumps and Compressors, Printing Machines, Paper Calanders, Uniformly Loaded Conveyors, Escalators, Liquid Agitators and Mixers, Rotary Driers, Fans	1	1.1	1.3
MODERATE SHOCKS	Pumps and Compressors (3+ cyls), Concrete Mixing Machines, Non uniformly Loaded Conveyors, Solid Agitators and Mixers	1.4	1.5	1.7
HEAVY SHOCKS	Planers, Excavators, Roll and Ball Mills, Rubber Processing Machines, Presses and Shears 1 & 2 Cyl Pumps and Compressors, Oil Drilling Rigs	1.8	1.9	2.1

Tooth Factor f2

The use of a tooth factor further modifies the final power selection. The choice of a smaller diameter sprocket will reduce the maximum power capable of being transmitted since the load in the chain will be higher.

Tooth factor f2 is calculated using the formula $f2 = \frac{19}{Z1}$

Note that this formula arises due to the fact that selection rating curves shown in the rating charts (see pages 107 and 108) are those for a 19 tooth sprocket.

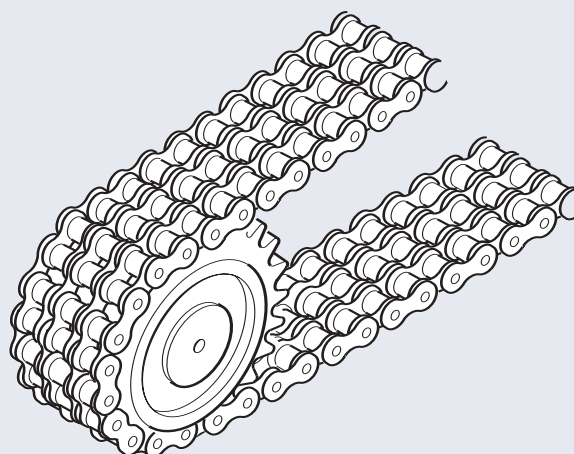

f2 factors for standard sprocket sizes

Z1	f2
15	1.27
17	1.12
19	1.00
21	0.91
23	0.83
25	0.76

3 Calculate The Selection Power

Multiply the power to be transmitted by the factors obtained from STEP TWO.

Selection POWER = POWER to be transmitted x f1 x f2 (kw).

This selection power can now be used with the appropriate rating chart, see pages 107 and 108.

4 Select Chain Drive

From the rating chart, select the smallest pitch of simplex chain to transmit the SELECTION POWER at the speed of the driving sprocket Z1.

This normally results in the most economical drive selection. If the SELECTION POWER is now greater than that shown for the simplex chain, then consider a multiplex chain of the same pitch size as detailed in the ratings chart.

5 Calculate Chain Length

To find the chain length in pitches (L) for any contemplated centre distance of a two point drive, use the formula below:

$$\text{Length (L)} = \frac{Z_1 + Z_2}{2} + \frac{2C}{P} + \frac{\left(\frac{Z_2 - Z_1}{2P}\right)^2 \times P}{C}$$

The calculated number of pitches should be rounded up to a whole number of even pitches. Odd numbers of pitches should be avoided because this would involve the use of a cranked link which is not recommended. If a jockey sprocket is used for adjustment purposes, two pitches should be added to the chain length (L).

C is the contemplated centre distance in mm and should generally be between 30 - 50 pitches.

e.g. for 1 1/2 " pitch chain C = 1.5 x 25.4 x 40 = 1524mm.

6 Calculate Exact Centre Distance

The actual centre distance for the chain length (L) calculated by the method above, will in general be greater than that originally contemplated. The revised centre distance can be calculated from the formula below.

$$C = \frac{P}{8} \left[2L - Z_2 - Z_1 + \sqrt{(2L - Z_2 - Z_1)^2 - \left(\frac{\pi}{3.88}\right) (Z_2 - Z_1)^2} \right]$$

Where P = Chain pitch (mm)
L = Chain length (pitches)
Z1 = Number of teeth in driver sprocket
Z2 = Number of teeth in driven sprocket

Drive with Multiple Sprockets

When designing a drive with multiple sprockets, the chain length calculation becomes more complicated. Most CAD systems, however, can be used to calculate chain length by wrapping a polyline around the PCD's of each sprocket. A scale manual drawing could also give a fairly accurate result as follows:

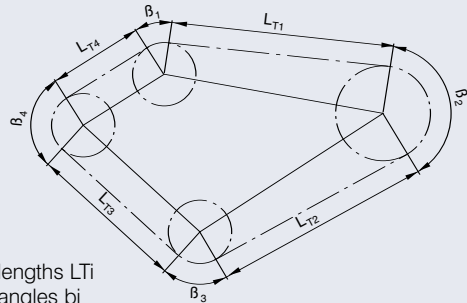

Measure lengths L_{Ti}
Measure angles beta_i

The theoretical length in pitches can now be calculated by the addition of all LT and b values using the following formula. Where:

P = the chain pitch
Z_i = the number of teeth

$$\text{Number of pitches} = \frac{1}{P} \sum_{i=1}^{i=n} L_{Ti} + \sum_{i=1}^{i=n} \frac{\beta_i Z_i}{360^\circ}$$

This calculation method can also be applied on drives where the chain is driven on guide rails or around jockey sprockets. These should be considered as ordinary sprockets.

Sprockets for Transmission Chain

Renold manufacture a comprehensive range of stock sprockets for European standard chains up to 2 inch pitch.

Other sizes of sprocket, including those to American standard dimensions, are available on request.

Special sprockets are also manufactured on request, in special materials or formats, normally to suit a specific application in harsh or difficult drive situations, examples being:

- Sprockets incorporating shafts.
- Welded or detachable hubs.
- Shear pin devices fitted.
- Necklace sprockets made up of chain plates and individual tooth sections for turning large drums or tables.
- Combination sprockets (two or more sprockets combined having different pitch sizes and numbers of teeth).
- Sprockets in two or more sections, ie split sprockets or segmental sprockets.

Renold Chain Designer Guide

Examples of two typical special sprockets.

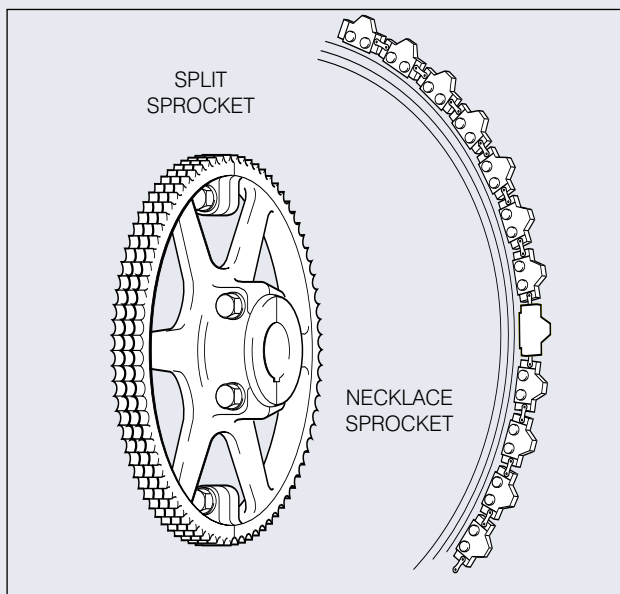

3

Selection of Sprocket Materials

Choice of material and heat treatment will depend upon shape, diameter and mass of the sprocket. The table below can be used as a simple guide on the correct selection of sprocket material.

SPROCKET	SMOOTH RUNNING	MODERATE SHOCKS	HEAVY SHOCKS
UP TO 29T	EN8 or EN9	EN8 or EN9 Hardened and Tempered or Case Hardened Mild Steel	EN8 or EN9 Hardened and Tempered or Case Hardened Mild Steel
30T AND OVER	Cast Iron	Mild Steel or Meehanite	EN8 or EN9 Hardened and Tempered or Case Hardened Mild Steel

Kilowatt ratings, for European and ANSI chains, shown in the ratings charts on pages 103 and 104 are based on the following conditions:-

- service factor of 1.
- wheel centre distance of 30 to 50 times the chain pitch.
- speed of driver sprocket (Z1) whether on the driving or driven shaft.
- two sprocket drive arrangement.
- adjustment by centre distance or jockey on unloaded strand.
- riveted endless chain (press fit connector).
- correct lubrication.
- accurate shaft/sprocket alignment.

Under these conditions a service life of approximately 15,000 hours can ordinarily be expected when the chain operates under full rating. The kilowatt ratings for multiple strand European chains up to triplex are given respectively in columns 2 and 3, for ANSI chains up to quadruplex in columns 2, 3 and 4.

Rating Chart Construction

The rating charts at first sight look complicated, however, they are constructed from 3 simple lines. From this it may be seen that at lower speeds the failure mode is likely to be plate fatigue if the maximum power recommendation is exceeded. However, pin galling will occur due to boundary lubrication break down at very high speeds. At the intersection of these lines the bush and roller fatigue curve comes into play and accounts for the rounded tops to each of the selection curves.

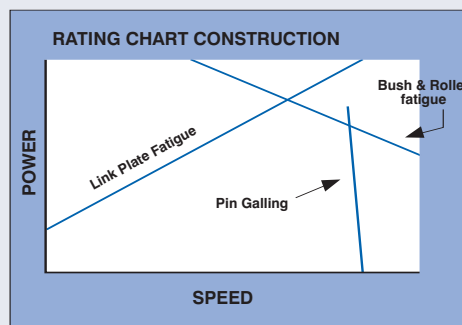

Bearing Pressures

When a chain has been correctly selected, the mode of failure over a very long period of time is most likely to be wear.

The subject of wear, which depends on many factors, has been addressed earlier in this guide, however, a very useful indicator of the likely wear performance is the magnitude of pressure between the key mating surfaces i.e. pin and bush.

This pressure is known as the bearing pressure and is obtained by dividing the working load by the bearing area. Bearing areas for standard chains are quoted in the designer data at the end of this guide.

The following table gives an indication of the implications of various bearing pressures but should not be used without reference to the other chain selection methods given in this guide.

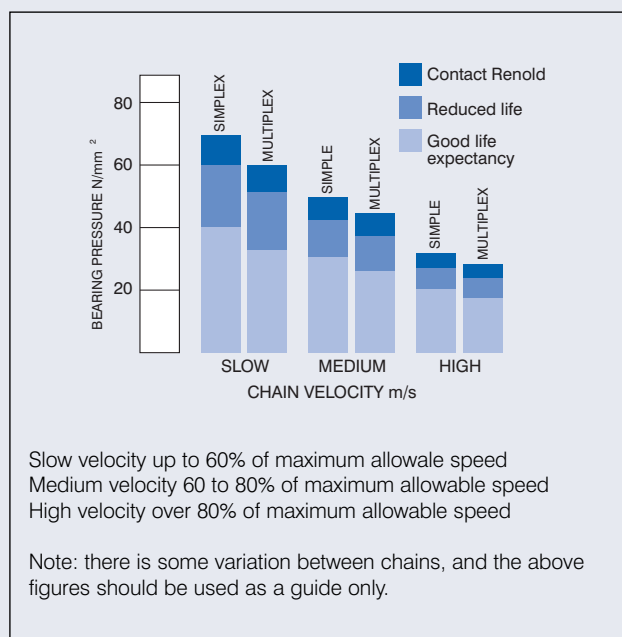

EUROPEAN STANDARD CHAIN DRIVES Rating Chart using 19T Driver Sprocket

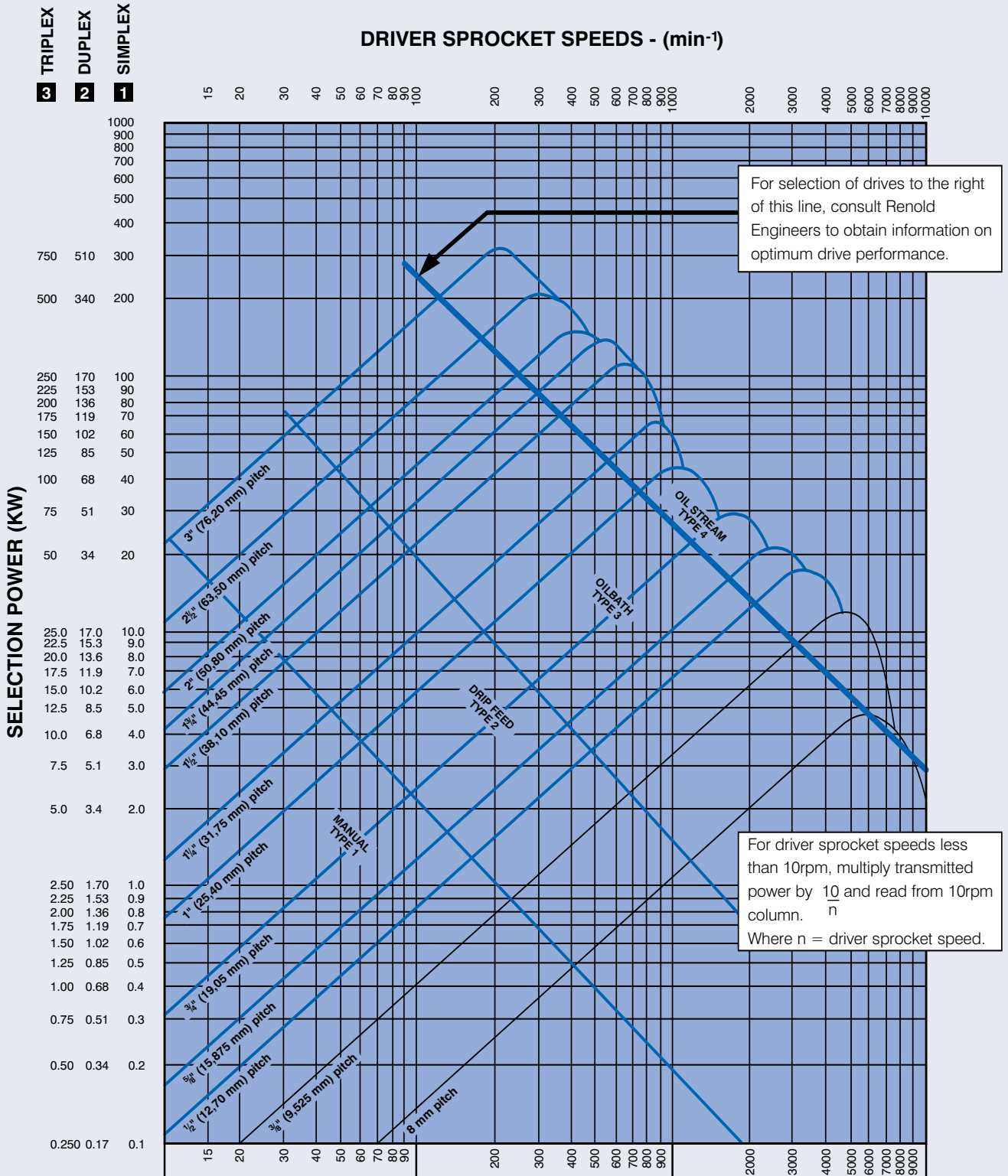

3

1 Kilowatt = 1.34 hp.

Renold Chain Designer Guide

ANSI Rating Chart

AMERICAN STANDARD CHAIN DRIVES
Rating Chart using 19T Driver Sprocket

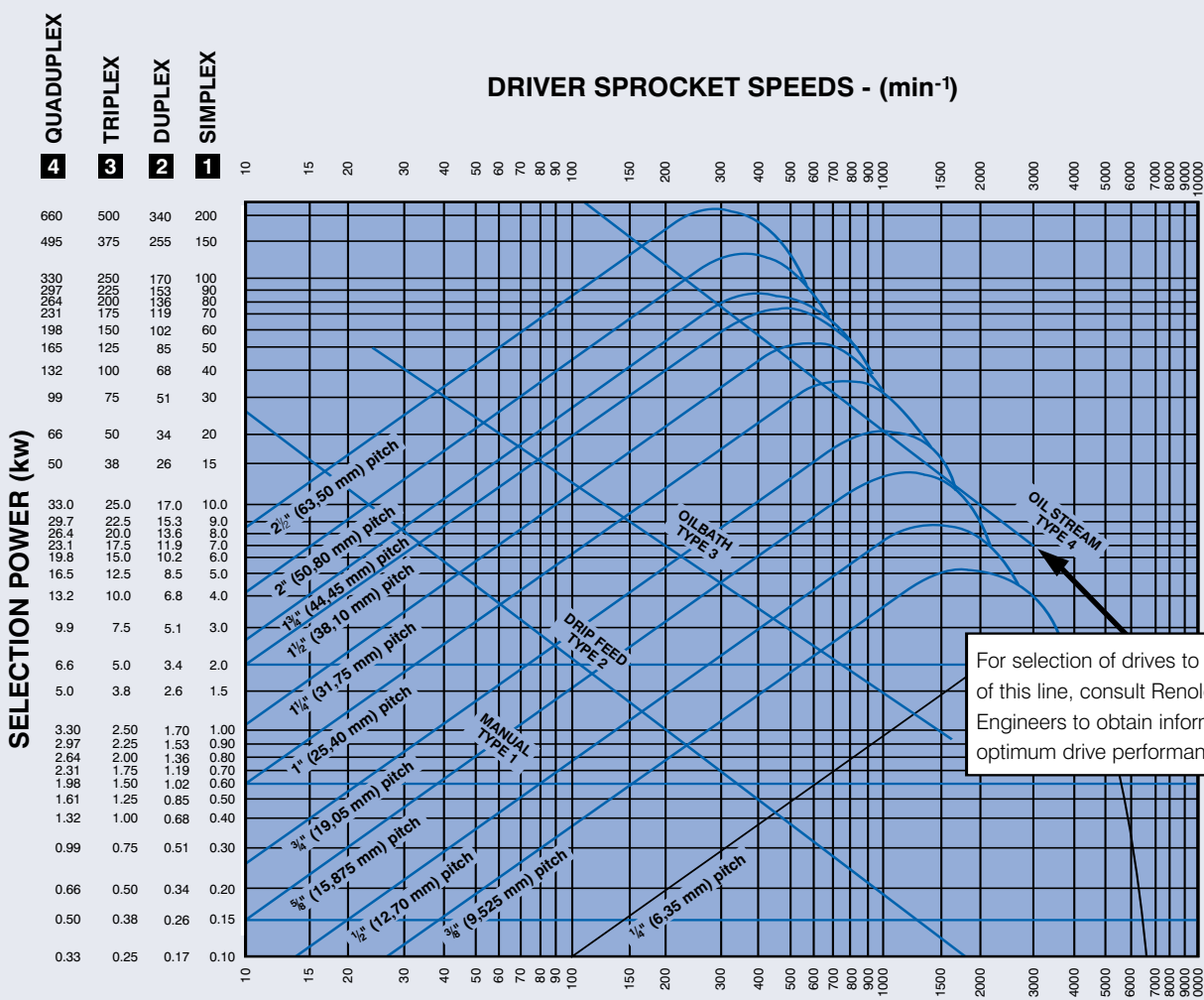

For selection of drives to the right of this line, consult Renold Engineers to obtain information on optimum drive performance.

Transmission Equations

The following equations give the relationships between power, torque and velocity for various drive arrangements.

Torque $M_d = \frac{F_1 \cdot d_1}{2000}$ or $\frac{9550 \cdot P_r}{n_1}$ (Nm)

Power $P_r = \frac{M_d \cdot n_1}{9550}$ or $\frac{F_1 \cdot v}{1000}$ (kw)

Force $F_1 = \frac{1000 \cdot P_r}{v}$ or $\frac{2000 \cdot M_d}{d_1}$ (N)

Velocity $v = \frac{n_1 \cdot Z_1 \cdot P}{60000}$ (m/s)

Where:

- M_d = Torque of the driver sprocket Nm
- P_r = Power kW
- d_1 = Pitch circle diameter of the driver sprocket in mm
- n_1 = Driver sprocket speed rpm
- Z_1 = Number of teeth in the driver sprocket
- Z_2 = Number of teeth in the driven sprocket
- v = Linear speed of the chain m/s
- F_1 = Chain pull N
- P = Pitch of the chain mm

Centripetal Acceleration

Centripetal acceleration affecting parts of the chain engaged on the sprockets is determined by:

$$F_2 = q \cdot v^2 \text{ (N)}$$

Where:

- F_2 = Force in N
- q = Mass of the chain in kg/m

From this formula we can see that at high speed, this force is not negligible and is the main reason for speed limitation.

Chain Suspension Force

The force acting between one link and the next due to the mass of the chain is small and is internally balanced within the chain. This will do no more than cause the chain to adopt a sagging catenary shape between the sprockets.

Allowance will need to be made in the installation for the slightly different postures adopted by the chain between zero and maximum load.

Lubrication

Chain drives should be protected against dirt and moisture and be lubricated with good quality non-detergent mineral based oil. A periodic change of oil is desirable. Heavy oils and greases are generally too stiff to enter the chain working surfaces and should not be used.

Care must be taken to ensure that the lubricant reaches the bearing areas of the chain. This can be done by directing the oil into the clearances between the inner and outer link plates, preferably at the point where the chain enters the sprocket on the bottom strand.

The table below indicates the correct lubricant viscosity for various ambient temperatures.

Ambient Temperature	Lubricant Rating	
Celsius	SAE	BS4231
-5 to +5	20	46 to 68
5 to 40	30	100
40 to 50	40	150 to 220
50 to 60	50	320

For the majority of applications in the above temperature range, a multigrade SAE 20/50 oil would be suitable.

Use of Grease

As mentioned above, the use of grease is not recommended. However, if grease lubrication is essential, the following points should be noted:

- Limit chain speed to 4 m/s.
- Applying normal greases to the outside surfaces of a chain only seals the bearing surfaces and will not work into them. This causes premature failure. Grease has to be heated until fluid and the chain is immersed and allowed to soak until all air bubbles cease to rise. If this system is used, the chains need regular cleaning and regreasing at intervals depending on the drives' power and speed. It should also be noted that temperatures above 80°C will cause damage to many greases and reduce their effectiveness.

Abnormal Ambient Temperatures

For elevated temperatures up to 250°C, dry lubricants such as colloidal graphite or MoS_2 in white spirit or poly-alkaline glycol carriers are most suitable.

Conversely, at low temperatures between -5°C and -40°C, special low temperature initial greases and subsequent oil lubricants are necessary. Lubricant suppliers will give recommendations.

Lubricating Methods

There are four basic methods for lubricating chain drives. The recommended lubrication method is based on the chain speed and power transmitted and can be found in the rating charts (see pages 107 and 108).

TYPE 1, Manual Operation

Oil is applied periodically with a brush or oil can, preferably once every 8 hours of operation. Volume and frequency should be sufficient to just keep the chain wet with oil and allow penetration of clean lubricant into the chain joints.

Health and Safety

Ensure all machinery is stationary and isolated, prior to applying any lubricant - carefully following machine manufacturers instructions.

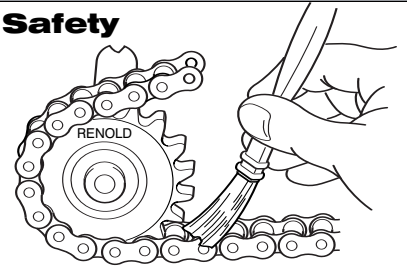

Applying lubricant by aerosol is also a satisfactory method, but it is important that the aerosol lubricant is of an approved type for the application, such as that supplied by Renold. This type of lubricant "winds" in to the pin/bush/roller clearances, resisting both the tendency to drip or drain when the chain is stationary and centrifugal "flinging" when the chain is moving.

TYPE 2, Drip Lubrication

Oil drips are directed between the link plate edges from a drip lubricator. Volume and frequency should be sufficient to allow penetration of lubricant into the chain joints.

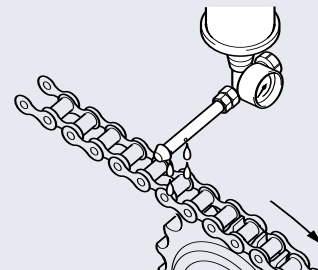

TYPE 3, Bath or Disc Lubrication

With oil bath lubrication the lower strand of chain runs through a sump of oil in the drive housing. The oil level should cover the chain at its lowest point whilst operating.

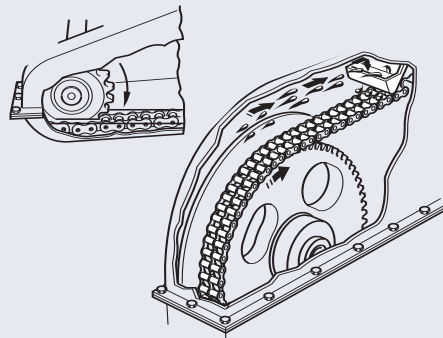

Renold Chain Designer Guide

With slinger disc lubrication an oil bath is used, but the chain operates above the oil level. A disc picks up oil from the sump and deposits it on the chain by means of deflection plates. When such discs are employed they should be designed to have peripheral speeds between 180 to 2440 m/min.

TYPE 4, Stream Lubrication

A continuous supply of oil from a circulating pump or central lubricating system is directed onto the chain. It is important to ensure that the spray holes from which the oil emerges are in line with the chain edges. The spray pipe should be positioned so that the oil is delivered onto the chain just before it engages with the driver sprocket.

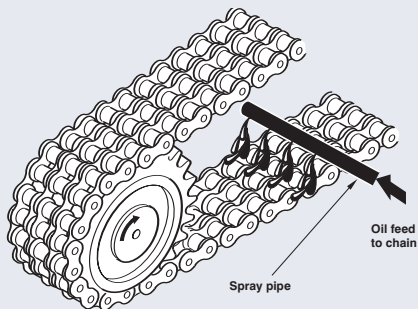

This ensures that the lubricant is centrifuged through the chain and assists in cushioning roller impact on the sprocket teeth. Stream lubrication also provides effective cooling and impact damping at high speeds.

Effect of Temperature

An important factor to control in a drive system is the chain and chaincase temperatures during operation. Depending on the severity of the drive service, continuity of use, etc., special attention to the lubrication method may be required.

Chain temperatures above 100°C should be avoided if possible due to lubrication limitations, although chain can generally give acceptable performance up to around 250°C in some circumstances. A way of improving the effectiveness of the lubrication and its cooling effect is to increase the oil volume (up to 4.5 litres per minute per chain strand) and incorporate a method of external cooling for the oil.

Lifting Applications

This section covers applications such as lifting and moving, where the loads involved are generally static. Obviously, dynamic loads are also involved in most applications and the designer needs to take due consideration of these. The machinery designer should also refer to DTI Publication INDY J1898 40M which summarises legislation in place from 1st January 1993 and 1st January 1995 regarding machinery product standards.

Chain for lifting applications falls into 2 main categories:

- Leaf Chains.
- Bush/Roller Chains.

Leaf Chain

Leaf chain is generally used for load balancing type lifting applications as illustrated below. They must be anchored at either end since there is no means of geared engagement in the chain itself.

Safety Factors

A safety factor of 7:1 is normal for steady duty reciprocating motion, e.g. fork lift trucks. For medium shock loads, 9:1 and for heavy shock loads, 11:1.

Operating Speed

Applications should not exceed a maximum chain speed of 30 metres/min.

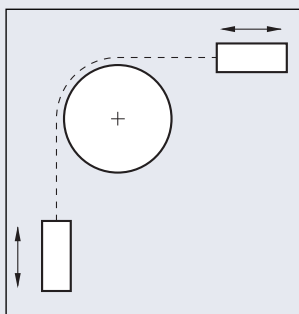

Applications

1. Machine Tools - Planers, Drills, Milling Heads, Machine Centres.

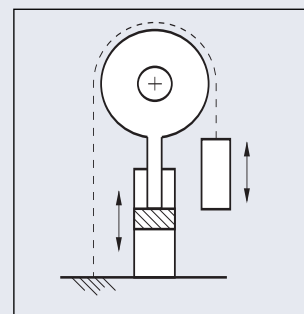

2. Fork Lift Trucks, Lifts, Hoists.

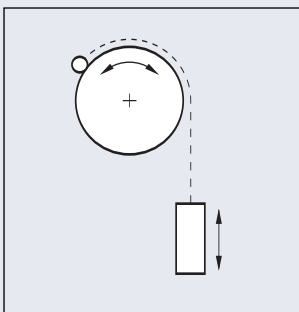

3. Counterweight Balances - Jacks, Doors, Gates etc.

Bush and roller chains can be used for lifting and moving purposes and have the advantage over leaf chain in that they may be geared into a suitable driving sprocket. Roller chain has a better wear resistance than leaf chain and may be used at higher speeds.

Safety Factors

Applications vary widely in the nature of loads applied and it is therefore recommended that factors of safety are applied which allow for some degree of abuse.

A factor of safety of 8:1 in non-passenger applications
A factor of safety of 10:1 in passenger applications

Lower factors of safety than these may be used (except for passenger applications), where careful consideration of the maximum loads and health and safety implications have been made. For comments on this see the section 'Influences on chain life'.

Operating Speeds

Applications should not normally exceed a maximum chain speed of 45 metres/min. For speeds higher than this, consider selection as if the chain were in a power transmission application converting the chain load to power using the following formula:

$$\text{POWER} = FV \text{ (kw)}$$

Where: F = Load KN
V = Velocity of chain (m/s)

Then apply selection power factors as shown in step 2 of 'DRIVE SELECTION'.

Calculate equivalent RPM by using the smallest sprocket in the system where speed = $\frac{60000V}{PZ}$

Where: P = Chain Pitch (mm)
Z = No of Teeth in Sprocket

Select lubrication methods also from the selection chart.

ANSI Xtra Range

Transmission chain is also available in heavy duty versions of the ANSI standard range of chain.

These chains are suitable where frequent or impulsive load reversals are involved. Typical applications are in primary industries such as mining, quarrying, rock drilling, forestry and construction machinery.

In order to accommodate these higher fatigue inducing loads, material for inner and outer plates is increased in thickness by approximately 20%.

This modification does not improve the tensile strength since the pin then becomes the weakest component. However, heavy duty chains with higher tensile strength are available. This is achieved by through hardening instead of case hardening the pin, but unfortunately this action reduces wear performance due to the lower pin hardness.

Renold ANSI XTRA chains are available as follows:

XTRA H RANGE	- Thicker plates
XTRA V RANGE	- Through hardened pins
XTRA HV RANGE	- Thicker plates and through hardened pins

The H and HV chains are not suitable or appropriate for high speed transmission applications.

The following points should also be noted:

- The V range of chains are totally interchangeable with standard ANSI chain.
- Simple chains of standard, H or HV designs all have identical gearing dimensions and therefore can operate on the same sprockets as for standard chains. The thicker plates will require a larger chain track and it may be desirable to use sprockets with heat treated teeth. Multiplex chain requires an increased transverse pitch of the teeth but other gearing dimensions are the same.
- The only reason to use H or HV chains is where fatigue life is a problem. We do not make any cranked (offset) links or slip-fit connecting links for this range, since these have a lower fatigue resistance.
- Detachable (cottered) versions can be produced if required as could triplex or wider chains.

Influences on Chain Life

Factors of Safety

All Renold chain is specified by its minimum tensile strength. To obtain a design working load it is necessary to apply a 'FACTOR OF SAFETY' to the breaking load. However, before considering this, the following points should be noted:

- Most chain side plates are manufactured from low to medium carbon steel and are sized to ensure they have adequate strength and also ductility to resist shock loading.
- These steels have yield strengths around 65% of their ultimate tensile strength. What this means is that if chains are subjected to loads of greater than this, depending upon the material used in the side plates, then permanent pitch extension will occur.
- Most applications are subjected to transient dynamic loads well in excess of the maximum static load and usually greater than the designer's estimate.
- Motors, for example, are capable of up to 200% full load torque output for a short period.

Renold Chain Designer Guide

3

The consequences of these points are that chain confidently selected with a factor of safety of 8:1 on breaking load is, in effect, operating with a factor of safety of around 5:1 on yield and much less than this when the instantaneous overload on the drive is considered.

Safety Factors			
Axial breaking force/max working load	12	Harsh Environments	Safety Critical
	11		
	10	Passenger Lifts	
	9	Transmission	
	8		
	7		
	6	High Cycle Lifting	
	5	Low Cycle Lifting	
	4		
	3	Not Normally Used	
	2		
	1		

A further consideration when applying a factor of safety to a chain application is the required chain life.

In a properly maintained application a life of 8,000,000 cycles or 15,000 hours, whichever comes first, is normal. Wear will be the usual mode of failure.

In applications where low factors of safety are required, the life will reduce accordingly.

The maximum working load is obtained by dividing the chain minimum tensile strength by the factor of safety.

The table below gives a rough indication of life for various factors of safety.

FACTOR		CYCLES MAXIMUM	TYPE OF APPLICATION
SIMPLE	MULTIPLEX		
5.0	6.0	1,000,000	Dynamic load does not exceed working load
6.0	7.2	2,000,000	
8.0	8.0	8,000,000	
10.0	10.0	8,000,000	Dynamic loads can occasionally exceed working load by 20% All Passenger Lifts

It should be noted that at factors below 8:1, bearing pressures increase above the maximum recommended, with the result that increased wear will arise unless special attention is taken with lubrication, e.g.:

- More frequent lubrication.
- Higher performance lubricants.
- Better methods of applying lubrication.

Important Note

For factors of 5:1 the resulting bearing pressure is 50% higher than recommended and chain working under these conditions will wear prematurely, whatever type of lubrication regime is used.

Harsh Environments

In anything other than a clean and well lubricated environment, the factor of safety should be adjusted if some detriment to the working life of the chain is to be avoided. Low temperatures will also decrease working life, especially if shock loads are involved.

The following tables give a general guide to the appropriate safety factors for different applications for a target life of 8,000,000 cycles.

Lubrication	Cleanliness		
	Clean	Moderately Clean	Dirty/Abrasive
	Regular	8	10
Occasional	10	12	14
None	12	12	14

Lubrication	Temperature (Celsius)		
	+10 to 150	150 to 200	200 to 300
	Regular	8	10
Occasional	10	12	14
None	12	12	14

Temperature °C	Load Regime		
	Smooth	Moderate	Shocks Heavy Shocks
	+10° to +150	8	11
0 to +10	10	15	19
-20 to Zero	12	20	25
-40 to -20	15	25	33

Chain Extension

When designing lifting applications it can be useful to know how much a chain will extend under a given load.

The approximate elongation of a chain under a given load can be measured by using the following formulae.

- Simplex chain

$$\Delta L = \frac{(14.51) \cdot 10^5 \cdot L}{p^2} \cdot F_1$$

- Duplex Chain

$$\Delta L = \frac{(9.72) \cdot 10^5 \cdot L}{p^2} \cdot F_1$$

- Triplex Chain

$$\Delta L = \frac{(7.26) \cdot 10^5 \cdot L}{p^2} \cdot F_1$$

Where:

- ΔL = Change in chain length mm
- L = Original length of the chain mm
- P = Pitch of the chain mm
- F_1 = Average load in the chain

Any application in which two or more strands of transmission chain are required to operate side by side in a common drive, or conveying arrangement, may involve the need for either pairing or matching. Such applications generally fall into one of the following categories :

Length Matching for Conveying and Similar Applications

Wherever length matching of transmission chain is necessary it is dealt with as follows:

- The chains are accurately measured in handling lengths between 3m to 8m as appropriate and then selected to provide a two (or more) strand drive having overall length uniformity within close limits. However, such length uniformity will not necessarily apply to any intermediate sections along the chains, but the actual length of all intermediate sections, both along and across the drive, will not vary more than our normal manufacturing limits. However, adapted transmission chains are usually manufactured to specific orders which are generally completed in one production run so that it is reasonable to assume that length differences of intermediate sections will be small.
- Chains are supplied in sets which are uniform in overall length within reasonably fine limits and will be within our normal manufacturing limits. It should be noted that chain sets supplied against different orders at different times may not have exactly the same lengths to those supplied originally, but will vary by no more than our normal tolerance of 0.0%, +0.15%.

Pitch Matching Transmission Drive Chains

Pitch matched chains are built up from shorter subsections (usually 300 to 600mm lengths) which are first measured and then graded for length. All subsections in each grade are of closely similar length and those forming any one group across the set of chains are selected from the same length grade.

The requisite number of groups are then connected to form a pitch matched set of chains, or alternatively, if this is too long for convenient handling, a set of handling sections for customer to assemble as a final set of pitch matched chain. Suitable tags are fixed to the chains to ensure they are connected together in the correct sequence.

Identification of Handling Lengths

	Handling Length 1	Handling Length 2	Handling Length 3
A Strand	A-A1	A1-A2	A2-A3
B Strand	B-B1	B1-B2	B2-B3
C Strand	C-C1	C1-C2	C2-C3

Long chains are made up in sections, each section being numbered on end links. Sections should be so joined up that end links with similar numbers are connected. Where chains are to run in sets of two or more strands, each strand is stamped on end links of each section with a letter, in addition to being numbered. Correct consecutive sections for each strand must be identified from the end links and joined up as indicated.

By these means, the actual length of any intermediate portion of one strand (as measured from any one pitch point to any other) will correspond closely with that of the transversely equivalent portion on the other strands, generally within 0.05mm, depending on the chain pitch size.

Pitch Matching Adapted Transmission Chains

(when attachments are fitted to chains)

With the sole exception of extended bearing pins, it is not possible to match the pitch of holes in attachments themselves to within very fine limits, due to the additional tolerances to be contended with (bending, holing, etc.).

Colour Coding

For customers who wish to match their chains, perhaps in order to fit special attachments in situ, Renold colour code short lengths of chain within specified tolerance bands. These will normally be RED, YELLOW or GREEN paint marks to indicate lower, mid and upper thirds of the tolerance band. For even finer tolerance bands additional colours can be used, but normally a maximum of five colours will be more than adequate.

COLOUR		
RED		0.05%
YELLOW		0.10%
GREEN		0.15%
BLUE		For Finer
WHITE		Tolerances

To Measure Chain Wear

A direct measure of chain wear is the extension in excess of the nominal length of the chain. The chain wear can therefore be ascertained by length measurement in line with the instructions given below.

- Lay the chain, which should terminate at both ends with an inner link (part No 4), on a flat surface, and, after anchoring it at one end, attach to the other end a turnbuckle and a spring balance suitably anchored.
- Apply a tension load by means of the turnbuckle amounting to:

SIMPLEX CHAIN	P2 x 0.77 (N)
DUPLEX CHAIN	P2 x 1.56 (N)
TRIPLEX CHAIN	P2 x 2.33 (N)

Where P is the pitch in mm.

Renold Chain Designer Guide

3

In the case of double pitch chains (e.g. chains having the same breaking load and twice the pitch) apply measuring loads as for the equivalent short pitch chains.

As an alternative, the chain may be hung vertically and the equivalent weight attached to the lower end.

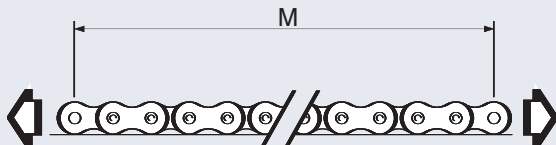

■ Measure length 'M' (see diagram above) in millimetres from which the percentage extension can be obtained from the following formula:

$$\text{Percentage Extension} = \frac{M - (N.P)}{N.P} \times 100$$

Where N = number of pitches measured

Where P = pitch

■ As a general rule, the useful life of the chain is terminated and the chain should be replaced when extension reaches 2 per cent (1 per cent in the case of double pitch chains). For drives with no provision for adjustment, the rejection limit is lower, dependent upon the speed and layout. A usual figure is between 0.7 and 1.0 per cent extension.

Renold Chain Wear Guide

A simple-to-use chain wear guide is available from Renold Chain for most popular sizes of chain pitch. Please contact your Sales Office for details.

Repair and Replacement

Sprockets

Examination of both flanks will give an indication of the amount of wear which has occurred. Under normal circumstances this will be evident as a polished worn strip about the pitch circle diameter of the sprocket tooth.

If the depth of this wear 'X' has reached an amount equal to 10% of the 'Y' dimension, then steps should be taken to replace the sprocket. Running new chain on sprockets having this amount of tooth wear will cause rapid chain wear.

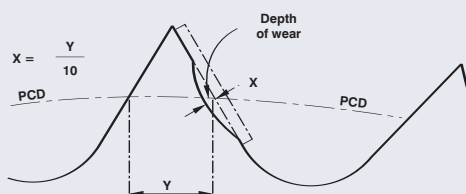

It should be noted that in normal operating conditions, with correct lubrication the amount of wear 'X' will not occur until several chains have been used.

Chain

Chain repair should not as a rule be necessary. A correctly selected and maintained chain should gradually wear out over a period of time (approximately 15000 hours), but it should not fail. Please refer to the Installation and Maintenance section, which gives an indication of the service life remaining.

If a transmission chain sustains damage due to an overload, jam-up, or by riding over the sprocket teeth, it should be carefully removed from the drive and given a thorough visual examination. Remove the lubricating grease and oil to make the job easier.

Depending on the damage, it may be practicable to effect temporary repairs using replacement links. It is not, however, a guarantee that the chain has not been over stressed and so made vulnerable to a future failure. The best policy, therefore, is to remove the source of trouble and fit a new chain. This should be done for the following reasons.

1. The cost of down time to the system or machine can often outweigh the cost of replacing the chain.
2. A new or even used portion of chain or joints assembled into the failed chain will cause whipping and load pulsation. This can, and probably will, produce rapid failure of the chain and will accelerate wear in both the chain and its sprockets.

If a chain has failed two or more times, it is certain the chain will fail again in time. If no replacement is immediately available, repair the chain, but replace it at the earliest opportunity.

Chain Adjustment

To obtain full chain life, some form of chain adjustment must be provided, preferably by moving one of the shafts. If shaft movement is not possible, an adjustable jockey sprocket engaging with the unloaded strand of the chain is recommended. Generally the jockey should have the same number of teeth as the driver sprocket and care should be taken to ensure the speed does not exceed the maximum shown in the rating charts (see pages 107 and 108).

The chain should be adjusted regularly so that, with one strand tight, the slack strand can be moved a distance 'A' at the mid point (see diagram below). To cater for any eccentricities of mounting, the adjustment of the chain should be tried through a complete revolution of the large sprocket.

A = Total movement
 C = Horizontal Centre Distance
 Total movement 'A' (mm) = $\frac{C \text{ (mm)}}{K}$

Where K = 25 for smooth drives
 50 for shock drives

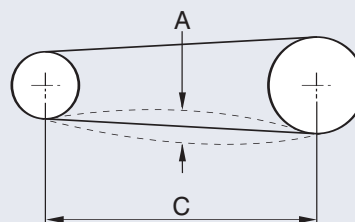

For vertical drives please consult the installation and maintenance section, which gives more details on chain adjustment.

Design Ideas

A variety of applications

Conveying, Indexing, Lifting and Pulling, Power Transmission, Timing.

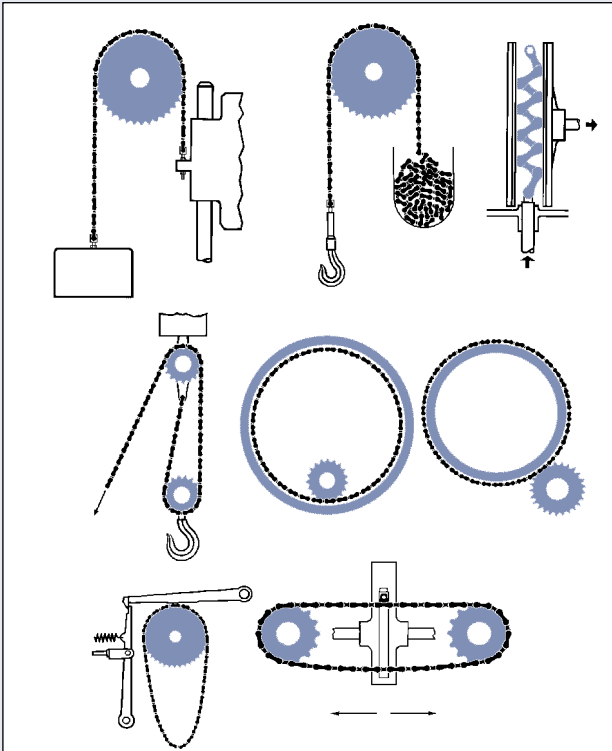

A variety of industries

Aircraft, Automotive, Marine, Mechanical Handling, Motorcycle, Nuclear, Oilfield.

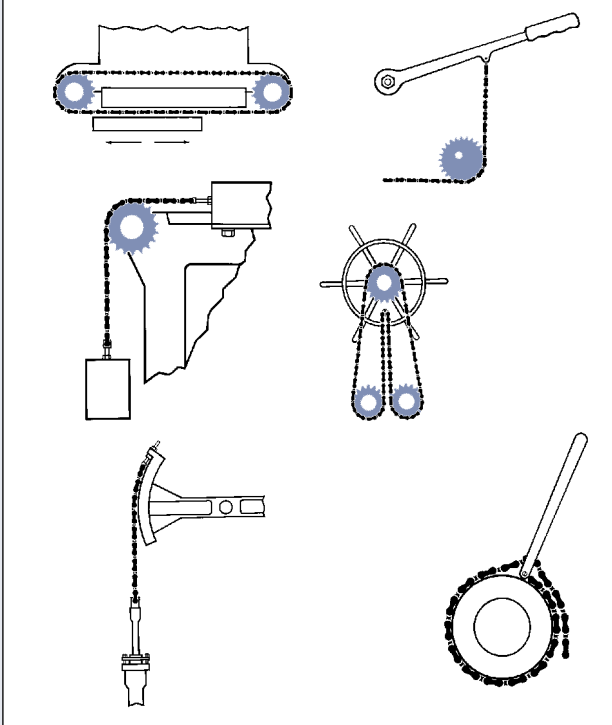

Table of PCD Factors

To obtain pitch circle diameter of any sprocket with 9 to 150 teeth, multiply chain pitch by appropriate factor.

e.g. The PCD of a 38T sprocket of 3/4" (19.05mm) pitch
 $= 19.05 \times 12.110 = 230.70\text{mm}$

Number of teeth	PCD Factor	Number of teeth	PCD Factor	Number of teeth	PCD Factor
9	2.924	57	18.153	105	33.428
10	3.236	58	18.471	106	33.746
11	3.549	59	18.789	107	34.064
12	3.864	60	19.107	108	34.382
13	4.179	61	19.426	109	34.701
14	4.494	62	19.744	110	35.019
15	4.810	63	20.062	111	35.337
16	5.126	64	20.380	112	35.655
17	5.442	65	20.698	113	35.974
18	5.759	66	21.016	114	36.292
19	6.076	67	21.335	115	36.610
20	6.392	68	21.653	116	36.928
21	6.709	69	21.971	117	37.247
22	7.027	70	22.289	118	37.565
23	7.344	71	22.607	119	37.883
24	7.661	72	22.926	120	38.202
25	7.979	73	23.244	121	38.520
26	8.296	74	23.562	122	38.838
27	8.614	75	23.880	123	39.156
28	8.931	76	24.198	124	39.475
29	9.249	77	24.517	125	39.793
30	9.567	78	24.835	126	40.111
31	9.885	79	25.153	127	40.429
32	10.202	80	25.471	128	40.748
33	10.520	81	25.790	129	41.066
34	10.838	82	26.108	130	41.384
35	11.156	83	26.426	131	41.703
36	11.474	84	26.744	132	42.021
37	11.792	85	27.063	133	42.339
38	12.110	86	27.381	134	42.657
39	12.428	87	27.699	135	42.976
40	12.746	88	28.017	136	43.294
41	13.063	89	28.335	137	43.612
42	13.382	90	28.654	138	43.931
43	13.700	91	28.972	139	44.249
44	14.018	92	29.290	140	44.567
45	14.336	93	29.608	141	44.885
46	14.654	94	29.927	142	45.204
47	14.972	95	30.245	143	45.522
48	15.290	96	30.563	144	45.840
49	15.608	97	30.881	145	46.159
50	15.926	98	31.200	146	46.477
51	16.244	99	31.518	147	46.795
52	16.562	100	31.836	148	47.113
53	16.880	101	32.154	149	47.432
54	17.198	102	32.473	150	47.750
55	17.517	103	32.791		
56	17.835	104	33.109		

Renold Chain Designer Guide

Simple Point to Point Drives - Example One

The following worked examples give simple step-by-step guidance on selecting various types of chain drive systems. Renold technical staff are available to advise on any chain selection problems. For details of transmission equations see page 108.

Example One Rotary Pump Drive

GIVEN:

- Pump speed 360 rpm
- Power absorbed 7.5 kw
- Driver Electric motor at 1440 rpm
- Constraints Centre distance approx 458 mm
Adjustment by shaft movement

1 Selection Parameters

- Use $Z_1 = 19T$
 - No polygonal effect
 - Satisfactory for smooth drives
- Calculate the drive ratio as follows:

$$\text{Drive Ratio} = i = \frac{Z_2}{Z_1} = \frac{N_2}{N_1} = \frac{1440}{360} = 4$$

Therefore the driven number of teeth

$$Z_2 = 4 \times Z_1 = 4 \times 19 = 76T$$

2 Selection Factors

Application Factor $f_1 = 1$ (driver and driven sprockets smooth running)

$$\text{Tooth Factor} \quad f_2 = \frac{19}{Z_1} = \frac{19}{19} = 1$$

$$\text{Selection Power} = 7.5 \times 1 \times 1 = 7.5 \text{kw}$$

3 Select Chain

The chain can now be selected using charts 3 and 4 and cross referencing power to speed, giving the following possibilities:

- 0.5" BS Simplex (Approx 81% of rated Capacity)
- 0.375" BS Duplex (Approx 98% of rated Capacity)
- 0.5" ANSI Simplex (Approx 83% of rated Capacity)
- 0.375" ANSI Duplex (Approx 84% of rated Capacity)

0.375" ANSI Duplex chain is unsuitable as it is a bush chain.

Note - The approximate percentage of rated capacity is calculated by dividing the selection power at 1440 rpm by the chains maximum capacity at 1440 rpm.

For this example we will choose 0.5" European Simplex

4 Installation Parameters

LUBRICATION - European Chain Rating Chart (see page 107) clearly indicates the chain needs OILBATH lubrication. The chain will need to be enclosed and run in a sump of oil.

We now calculate the CHAIN LENGTH

$$L = \frac{Z_1 + Z_2}{2} + \frac{2C}{P} + \frac{P}{C} \left(\frac{Z_2 - Z_1}{2\pi} \right)^2$$

$$L = \frac{19 + 76}{2} + \frac{2 \times 458}{12.7} + \frac{12.7 \left(\frac{76 - 19}{2\pi} \right)^2}{458} = 121.9$$

Round up to the nearest number of even pitches i.e. 122.

5 Centre Distance Calculation

The centre distance of the drive can now be calculated using the formula shown below:

$$= \frac{P}{8} \left[2L - Z_2 - Z_1 + \sqrt{(2L - Z_2 - Z_1)^2 - \frac{\pi}{3.88} (Z_2 - Z_1)^2} \right]$$

$$= \frac{12.7}{8} \left[((2 \times 122) - 76 - 19) + \sqrt{((2 \times 122) - 76 - 19)^2 - \frac{\pi}{3.88} \times (76 - 19)^2} \right]$$

$$= 458.6 \text{mm}$$

6 Adjustment

Provide for chain wear of 2% or two pitches, whichever is smaller, in this case, $(122 \times 1.02) - 122 = 2.44$ pitches.

Therefore use 2 pitches and recalculate using:

$$L = 124 \text{ in the above equation. This gives}$$

$$C = 471.7 \text{mm}$$

i.e. total adjustment of 13.1mm.

Note that in practice, some negative adjustment will facilitate assembly and will be essential if it is intended to assemble chain which is pre-joined into an endless loop.

7 Other Data

$$\text{Chain Velocity} = \frac{N.P. Z_1}{60000} = \frac{1440 \times 12.7 \times 19}{60000} = 5.79 \text{m/s}$$

$$\text{Load in chain due to power transmitted} = \frac{Q \cdot 1000}{v}$$

(Where Q = Selection power (kw))

$$= \frac{7.5 \times 1000}{5.79} = 1295 \text{N}$$

$$\text{Load in chain due to centripetal acceleration}$$

$$= \text{Chain mass/metre} \times \text{Velocity}^2$$

$$= 0.68 \times 5.79^2$$

$$= 23 \text{N}$$

$$\text{Total chain working load} = 1318 \text{N}$$

Note the load in the chain due to centripetal acceleration becomes much more significant at higher speeds since the square of the chain velocity is in the equation.

$$\text{Chain axial breaking force} = 19000 \text{N}$$

(See pages 10-11)

$$\text{Chain safety factor} = \frac{1900}{1318} = 14.4$$

$$\text{Chain bearing area} = 50 \text{mm}^2 \text{ (see pages 8-9 and 34-35)}$$

$$\text{Bearing pressure} = \frac{\text{WORKING LOAD}}{\text{BEARING AREA}} = \frac{1318}{50} = 26.36 \text{N/mm}^2$$

The following worked examples give simple step-by-step guidance on selecting various types of chain drive systems. Renold technical staff are available to advise on any chain selection problems. For details of transmission equations see page 108.

Example Two 4-Cylinder Compressor

GIVEN:

- Pump speed 250 rpm
- Power absorbed 250 kw
- Driver Electric motor at 960 rpm
- Constraints Centre distance approx 1500 mm

1 Selection Parameters

Use a 25T sprocket for an impulsive drive (see page 103 selection of drive ratio and sprockets).

$$\text{Drive Ratio} = \frac{Z_2}{Z_1} = \frac{N_2}{N_1} = \frac{960}{250} = 3.84$$

Number of teeth $Z_2 = 3.84 \times Z_1 = 3.84 \times 25 = 95T$

2 Selection Factors

Application Factor $f_1 = 1.5$ (driver and driven sprocket medium impulsive)

$$\text{Tooth Factor } f_2 = \frac{19}{Z_1} = \frac{19}{25} = 0.76$$

Selection Power = Transmitted power $\times f_1 \times f_2$ (kw)
Selection Power = $250 \times 1.5 \times 0.76 = 285\text{kw}$

3 Select Chain

The chain can now be selected using European Chain Rating Chart (see page 107) by cross referencing the power (285kw on the vertical axis) and speed (960 rpm on the horizontal axis).

Two matched strands of 1.25" pitch European triplex chains could be used with a heat treated 25 tooth steel driver and a 95 tooth driven sprocket to give a drive ratio of 3.8 to 1.

4 Installation Parameters

LUBRICATION - European Chain Rating Chart (see page 107) clearly shows that an oilstream system is required on this drive. The chain should run in an enclosure with a pump and sump arrangement.

We will now calculate the CHAIN LENGTH

$$L = \frac{25 + 95}{2} + \frac{2 \times 1500}{31.75} + \frac{31.75 \left(\frac{95 - 25}{2\pi} \right)^2}{1500} = 157.12$$

Round up to the nearest number of even pitches i.e. 158

5 Centre Distance Calculation

The centre distance of the drive can now be calculated using the standard formula below:
= 1514.44mm

$$C = \frac{31.75}{8} \left[\left((2 \times 158) - 95 - 25 \right) + \sqrt{\left((2 \times 158) - 95 - 25 \right)^2 - \frac{\pi}{3.88} (95 - 25)^2} \right]$$

6 Adjustment

$$\text{Chain Velocity} = \frac{960 \times 31.75 \times 25}{60000} = 12.7 \text{ m/s}$$

$$\text{Load in the Chain} = \frac{285 \times 1000}{12.7} = 22440 \text{ N}$$

$$\text{Load in the chain due to centripetal acceleration} = 11.65 \times 2 \times 12.7 \times 12.7 = 3758 \text{ N}$$

$$\text{Total chain WORKING LOAD} = 26027 \text{ N}$$

$$\text{Bearing Pressure} = \frac{\text{WORKING LOAD}}{\text{BEARING AREA}} = \frac{23272}{885 \times 2} = 14.7 \text{ N/mm}^2$$

$$\text{Chain Safety Factor} = \frac{\text{BREAKING LOAD}}{\text{WORKING LOAD}} = \frac{294200 \times 2}{26027} = 22.6$$

Multi-Shaft Drives

SHAFTS IN SERIES

This arrangement shows the driving of live roller conveyors.

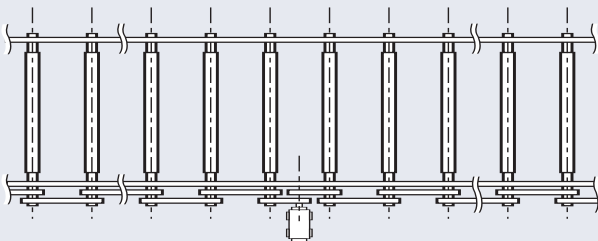

The choice of the chain is based on the slipping torque between the rollers and the material to be transported. The safety factor to be applied for this type of drive is typically:

Safety factor = 5 for one direction drives
Safety factor = 8 for reversible drives

Every roller except the last comprises two simple sprockets, or one special sprocket to be used with two simple chains. At low speeds or in reversible drives, sprockets with hardened teeth should be used.

Roller conveyors with less than 10 rollers can be driven from one of the ends of the track. When the number of rollers is higher, it is recommended that the driving arrangement is in the middle of the conveyor in order to have a better distribution of the power and the highest overall efficiency.

If we assume that a drive operating under ideal conditions such as a clean environment and correct lubrication achieves an efficiency of R%, then the overall efficiency of a roller conveyor with X rollers will be:

$$100 \left(\frac{R}{100} \right)^X = \frac{R^X}{100^{(X-1)}}$$

If the individual drive efficiency R is equal to 98%, then the drive of a roller conveyor with 30 rollers will therefore only have an overall efficiency of 55%

Consequently, it is recommended that no more than 30 rollers per drive are used. For roller conveyors with more than 30 rollers, use multiple drives.

The drive should be able to develop a torque corresponding to the slipping torque of the loaded rollers.

Renold Chain Designer Guide

Simple Point to Point Drives - Example Three

The following worked examples give simple step-by-step guidance on selecting various types of chain drive systems. Renold technical staff are available to advise on any chain selection problems. For details of transmission equations see page 108.

Example Three

GIVEN:

- Moving a stack of steel plates.
- 20 rollers with a diameter of 150mm.
- Shafts with a diameter of 60mm on ball bearings.
- Weight of one roller 1900N.
- There are two stacks on the conveyor at any one time.
- One stack weighs 17500N with a length of 1500mm.
- Total nett load : 35000N (two stacks).
- Centre distance of the rollers : 300mm.
- Linear speed : 15 m/min.
- PCD of the sprockets : 140mm.
- Impulsive load : 30 starts per hour, in one direction.

1 Assumptions

- A drive is placed in the middle with 10 rollers on each side
- The rolling resistance of the rollers is 0.05
- The friction resistance between the rollers and the load is 0.25
- The efficiency per drive is 98%

2 Selection Calculations

Every stack of steel is 17500 N and is conveyed by

$$\frac{\text{Stack length}}{\text{Centre distance of rollers}} = \frac{1500}{300} = 5 \text{ Rollers}$$

or 10 rollers for the total nett load.

If a nett load of 35000 N is added to the total weight of 10 bearing rollers (19000 N), then this gives a gross load of 54000 N. The tangential force for 10 rollers is : $54000 \times 0.05 = 2700 \text{ N}$ and the corresponding torque is:

$$F \times d \text{ (force x distance)} = 2700 \times \frac{0.06}{2} = 81 \text{ Nm}$$

Note: Where d = shaft diameter

For each group of 10 rollers the efficiency will be:

$$\frac{98^{10}}{100^9} = 81.7\%$$

The effective torque then becomes:

$$\frac{\text{Actual Torque}}{\text{Efficiency}} = \frac{81}{0.817} = 99 \text{ Nm}$$

For sprockets with a pitch circle diameter of 140mm, the pull in the chain will be:

$$\frac{2000 \times Md}{d_1} = \frac{2000 \times 99}{140} = 1414 \text{ N}$$

The friction force for a friction coefficient of 0.25 is $35000 \times 0.25 = 8750 \text{ N}$

The corresponding torque is equal to:

$$F \times d \text{ (force x distance)} = 8750 \times \frac{0.15}{2} = 656 \text{ Nm}$$

Note: Where d = radius of shaft

The total drive torque is $656 + 81 = 737 \text{ Nm}$

The effective torque is therefore:

$$\frac{737}{0.817} = 902 \text{ Nm}$$

The pull in the chain then becomes:

$$\frac{2000 \cdot Md}{d_1} = \frac{2000 \times 902}{140} = 12886 \text{ N}$$

Per drive we can now evaluate chain ISO 16B-1 or Renold Chain 110088 running with two sprockets with 17 teeth and a pitch circle diameter of 138mm.

In normal use:

The safety factor $\frac{\text{Axial Breaking force}}{\text{Working load}} = \frac{67000}{1414} = 47.4$

Bearing pressure $\frac{\text{Working load}}{\text{Bearing area}} = \frac{1414}{207} = 6.83 \text{ N/mm}^2$

When slipping they are:

The safety factor $\frac{\text{Axial Breaking Force}}{\text{Pull in Chain}} = \frac{67000}{12886} = 5.2$

Bearing pressure $\frac{\text{Chain Pull}}{\text{Bearing Area}} = \frac{12886}{207} = 62.26 \text{ N/mm}^2$

The linear speed of the chain is:

$$\frac{\text{stack speed} \times d_1}{\text{roller dia}} \left(\frac{1}{60} \right) = \frac{15 \times 0.138}{0.15 \times 60} = 0.23 \text{ m/sec}$$

Note: Where d1 = PCD of sprocket in metres

For each group of 10 rollers the power is: $\frac{F_1 V}{1000}$

Under normal working conditions

$$\frac{\text{Working load} \times \text{linear speed}}{1000} = \frac{1414 \times 0.23}{1000} = 0.33 \text{ kW}$$

$$\frac{\text{Chain pull} \times \text{linear speed}}{1000} = \frac{12886 \times 0.23}{1000} = 2.96 \text{ kW}$$

When the rollers are slipping

- Taking the efficiency of the gear unit into account and adding a factor of 25% to this total power, 3.7kW will be necessary.

NOTE - At higher linear speeds, we should also take into account other additional factors such as the moment of inertia of the rollers and the power needed to accelerate the various components of the system.

Shafts in Parallel

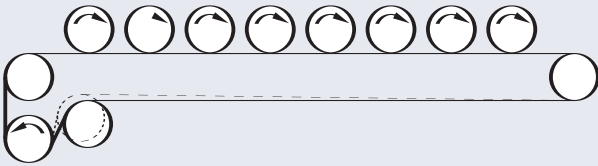

Figure 1

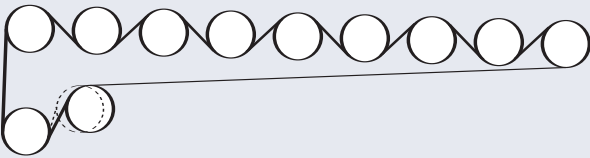

Figure 2

Drives of this type will only be used when:

- There is a steady load, preferably divided evenly over the sprocket system.
- At linear speeds not higher than 1.5 m/sec.
- It is driven in one direction only.

The efficiency of this driving method is higher than for the series drive because there is reduced tooth contact.

Every drive needs special attention with regard to the positioning of the driver sprocket, the jockey and the reversing pinions.

The layout of the sprockets, the support and the guidance of the chain determine to a large extent, the service life of the chain.

The chain in most cases is quite long and a good grip on the driver sprocket is only possible when a degree of pre-tensioning is applied. This should never exceed half the normal pulling load of the application.

The method of selection is the same as for that detailed under SHAFTS IN SERIES.

Drives mounted as in figure 2 have an efficiency under normal conditions of:

- 94% with 5 rollers
- 89% with 10 rollers
- 84% with 15 rollers
- 79% with 20 rollers
- 75% with 25 rollers

Safety Warnings

Connecting Links

No 11 or No 26 joints (slip fit) should not be used where high speed or arduous conditions are encountered. In these or equivalent circumstances where safety is essential, a riveting link No 107 (interference fit) must be used.

Wherever possible, drives should have sufficient overall adjustment to ensure the use of an even number of pitches throughout the useful life of the chain. A cranked link joint (No 12 or No 30) should only be used as a last resource and restricted to light duty, non-critical applications.

Chain Maintenance

The following precautions must be taken before disconnecting and removing a chain from a drive prior to replacement, repair or length alteration.

1. Always isolate the power source from the drive or equipment.
2. Always wear safety glasses.
3. Always wear appropriate protective clothing, hats, gloves and safety shoes, as warranted by the circumstances.
4. Always ensure tools are in good working condition and used in the proper manner.
5. Always loosen tensioning devices.
6. Always support the chain to avoid sudden unexpected movement of chain or components.
7. Never attempt to disconnect or reconnect a chain unless the method of safe working is fully understood.
8. Make sure correct replacement parts are available before disconnecting the chain.
9. Always ensure that directions for correct use of any tools is followed.
10. Never re-use individual components.
11. Never re-use a damaged chain or chain part.
12. On light duty drives where a spring clip (No 26) is used, always ensure that the clip is fitted correctly in relation to direction of travel.