



Product catalogue 3rd edition

Standard Equipment and Welding Automation



Contents

Welding equipment

MMA equipment	3
Engine driven welders	7
TIG equipment	9
MIG/MAG equipment	17
Ancillary equipment	45
Manual plasma cutting equipment	50

Welding automation

Orbital TIG welding	58
Universal mechanisation equipment	70
Tractor automats	72
Welding heads, power sources	78
Carriers and gantries	82
Wear parts	84
Components and modules	86
Flux equipment	88
Column and boom	90
Handling equipment, seamers	92
Engineering	
Arc Welding	95
Friction Stir Welding	96
Resistance Welding	97
Welding solutions delivered by Automation	98

MMA equipment

Inverters



Origo™ Arc 150i/200i

- Sturdy design – stable construction that can withstand rough handling
- IP 23 – fit for outdoor use, which makes it safe on all work sites
- Can be fitted with extended mains cables – extends the working range

Delivery includes

3 m mains cable. Origo™ Arc 150i with mains plug and Origo™ Arc 200i without plug.

Origo™ Arc 150i Origo™ Arc 200i

	Origo™ Arc 150i	Origo™ Arc 200i
Mains supply, V/Hz	230/1 50-60	230/1 50/60
Fuse, slow, A	16	>16 A @ 180 A
Mains cable, Ø mm ²	2.5	4.0
Max output at 25% duty cycle, A	150	180
Max output at 35% duty cycle, A	140	160
Max output at 60% duty cycle, A	110	140
Max output at 100% duty cycle, A	90	120
Setting range, A	4-150	5-180
Open circuit voltage, V	60-75	60-75
Weight, kg	6.9	8.0

Ordering information

Origo™ Arc 150i	0459 200 880
Origo™ Arc 200i	0459 200 882
Origo™ Arc 150i, package	0459 200 884
Origo™ Arc 200i, package	0459 200 888
Shoulderstrap	0459 368 880
MMA welding and return cable kit 150A ("crocodile")	0349 501 078
MMA welding and return cable kit 150A ("screw")	0349 501 079
MMA welding and return cable kit 200A ("screw")	0700 006 881



Caddy™ Arc 150i

- Practical design – makes the power source easy to carry, thereby enabling it to be used at almost any work site
- Adjustable hot start – easy to strike the electrode, thereby avoiding starting problems
- Adjustable arc force – adaptation to electrode type giving improved weld quality
- IP 23 – fit for outdoor use, which makes it the ideal machine for on-site work
- ArcPlus™ – better welding characteristics, simplifies your work and gives you better quality

Delivery includes

3 m mains cable with plug.

Caddy™ Arc 150i

	Caddy™ Arc 150i
Mains supply, V/Hz	230/50-60
Fuse, slow, A	16
Mains cable, Ø mm ²	2.5
Max output at 35% duty cycle, A	140
Max output at 60% duty cycle, A	110
Max output at 100% duty cycle, A	90
Setting range, A	4-150
Open circuit voltage, V	60-75
Weight, kg	7.7

Ordering information

Caddy™ Arc 150i	0459 199 880
Caddy™ Arc 150i, package	0459 199 884
Shoulder strap	0459 367 880
Trolley	0459 366 880
MMA welding and return cable kit 150A ("crocodile")	0349 501 078
MMA welding and return cable kit 150A ("screw")	0349 501 079
Remote control MMA 1, 10 m cable	0349 501 024
TIG torch TXH™ 120V, 4 m	0460 010 841
TIG torch TXH™ 150V, 4 m	0460 011 843
Remote control AT1	0459 491 896
Cable, 5 m	0459 553 880
Cable 10 m	0459 552 881

For TIG torches, see page 13-15

For trolleys, see page 44

For remote controls, see page 45-47

MMA equipment

Inverters



Caddy™ Professional 200/250

More than 20 years experience of inverter technology has resulted in this machine. A repair and maintenance tool that you can bring anywhere.

The lightweight Caddy™ with its ergonomic design is the ideal partner when the weld is in difficult places; away from mains, up masts, down holes...

Delivery includes

3 m mains cable and complete welding and return cables with OKC connections.

	LHN 200	LHN 250
Mains supply, V/Hz	400 (380-415)/50-60	400/50-60
Fuse, slow, A	16	16
Mains cable, Ø mm ²	4x1.5	4x2.5
Max output at 35% duty cycle, A	200	250
Max output at 60% duty cycle, A	150	180
Max output at 100% duty cycle, A	115	140
Setting range, A	5-200	4-250
Open circuit voltage, V	53-75	50-80
Weight, kg	11	11

Ordering information

Caddy™ Professional 200, 3-ph 400 V	0468 220 880
Caddy™ Professional 250, 3-ph, 400 V	0457 516 880
TXH™ 120V, 4m	0460 010 841
TXH™ 150V, 4 m	0460 011 841
TXH™ 200V, 4 m	0460 012 841
Remote control MMA 1, 10 m cable	0349 501 024
Remote control AT 1	0459 491 896
Cable, 5 m	0459 552 880
Cable, 10 m	0459 552 881
For TIG torches, see page 13-15	
For remote controls, see page 45-47	



Aristo™ Arc 4000i/5000i, A4 Origo™ Arc 4000i/5000i, A2

Outstanding welding characteristics – high efficiency and high-quality welding. Efficient Man Machine Communication by the user-friendly control panels A2 for Origo™ or A4 for Aristo™ enables the choice of electrode types, rutile, basic and cellulose for optimal welding qualities and an easy-to-read digital display to indicate current/voltage.

- Adjustable arc force
- Adjustable hot start (A4) to optimise welding starts
- Carbon Arc Gouge (A4) with up to 10 mm gouging electrodes
- Multi-voltage unit as an add-on or separate unit for a wide range of mains power supplies
- Enclosure class IP 23
- Dust filter to handle tough and dirty environments and avoid grinding- dust and metal particles inside the chassis

Delivery includes

5 m mains cable incl. plug

	Arc 4000i	Arc 5000i
Mains supply, V/Hz	3x400/50-60	3x400/50-60
Fuse, slow, A	25	35
Mains cable, Ø mm ²	4x4	4x6
Max output at 35% duty cycle, A	400/36 V	-
Max output at 60% duty cycle, A	320/33 V	500/40
Max output at 100% duty cycle, A	250/30 V	400/36
Setting range, A	16-400	16-500
Open circuit voltage, V	78-90	68-80
Weight, kg	45	55

Ordering information

Origo™ Arc 4000i A2	0458 635 880
Aristo™ Arc 4000i A4	0458 635 881
Origo™ Arc 5000i A2	0459 130 880
Aristo™ Arc 5000i A4	0459 130 881
For trolleys, see page 44	
For remote controls, see page 45-47	
For multi-voltage unit, see page 43	

MMA equipment

Rectifiers



Origo™ Arc 250/300/400

- Low investment cost per amperage
- No electronics – an advantage for remote operations
- Multi-voltage version available
- Approved according to European standards – CE labelled
- Supplies direct current – welds most materials
- Made to be used with Citoflex cellulosic electrodes
- Designed for use in damp and confined areas – S marked

Delivery includes

Wheels, handles and a 3 m mains cable.

	Origo™ Arc 250	Origo™ Arc 300	Origo™ Arc 400
Mains supply, V/Hz	400/50-60	400/50-60	400/50-60
Fuse, slow, A	25	25	35
Setting range, A	50-250	55-300	65-400
Open circuit voltage, V	65-75	65-75	70-80
Weight, kg	98	105	158

Ordering information

Origo™ Arc 250	0700 160 880
Origo™ Arc 250, 230/400/500/550 V, 50/60 Hz	0700 160 883
Origo™ Arc 300	0700 160 881
Origo™ Arc 300, 230/400/500/550 V, 50/60 Hz	0700 160 884
Origo™ Arc 400	0700 160 882
Origo™ Arc 400, 230/400/500/550 V 50/60 Hz	0700 160 885



LHF 400/630/800

The LHF 400/630/800 rectifiers are designed to meet the highest expectations in terms of robustness and operational performance and reliability. Dynamic characteristics, current range, “anti-stick” function and power capacity make the LHF a tool for contractors and fabricators who require top performance. LHF’s are also good for TIG scratch starts or with TIG add-on units. The 630 and 800 have been optimized for carbon arc gouging.

Delivery includes

Two OKC welding cable connectors, wheels and assembly elements.

	LHF 400	LHF 630	LHF 800
Mains supply, V/Hz	400/415/ 500/50Hz, 440-460/ 550/60Hz	400/415/ 500/50Hz, 440-460/ 550/60Hz	400/415/ 500/50Hz, 440-460/ 550/60Hz
Fuse, slow, A	25	50	63
Mains cable, Ø mm ²	4x4	4x10	4x10
Max output at 35% duty cycle, A	400	630	800
Max output at 60% duty cycle, A	315	500	630
Max output at 100% duty cycle, A	250	400	500
Setting range, A	8-400	8-630	8-800
Open circuit voltage, V	80-87	65-72	65-72
Weight, kg	195	260	295

Ordering information

LHF 400*	0319 783 882
LHF 400 Stationary	0319 783 885
LHF 400 Offshore*	0319 783 886
LHF 630*	0319 950 882
LHF 630 Stationary	0319 950 885
LHF 630 Offshore*	0319 950 886
LHF 800 Offshore*	0319 951 884
LHF 400 w V/A-meter and time control fan	0468 680 880
LHF 630 w V/A-meter and time control fan	0468 680 881
*400/415/500 V, 50 Hz, 440/550 V, 60 Hz	
For remote controls, see page 45-47	

MMA equipment

Rectifiers



LHF 405/615 PIPEWELD

LHF 405 PIPEWELD and LHF 615 PIPEWELD are sturdy and robust thyristor-controlled units intended for manual heavy-duty MMA welding with coated electrodes, TIG welding and arc air gouging. The welding properties of these units are configured to meet the requirements for welding with celluloid electrodes. The LHF 405/615 PIPEWELD units have a strong galvanised metal housing. The large wheels make them easy to move. Thus this range of units is particularly recommended for the highest requirements and toughest areas of application. Well-proven technology provides high reliability and outstanding welding performance.

Delivery includes

Two OKC welding cable connectors, wheels and assembly elements.

	LHF 405 PIPEWELD	LHF 615 PIPEWELD
Mains supply, V/Hz	230/400/415/ 500/50Hz, 230/ 440-460/550/ 60Hz	230/400/415/ 500/50Hz, 230/ 440-460/550/ 60Hz
Fuse, slow, A	35	63
Mains cable, Ø mm ²	4x6	4x10
Max output at 35% duty cycle, A	400 A	610 A
Max output at 60% duty cycle, A	310 A	450 A
Max output at 100% duty cycle, A	240 A	345 A
Open circuit voltage, V	75	81
Weight, kg	215	303

Ordering information

LHF 405 PIPEWELD	0349 307 046
LHF 615 PIPEWELD	0349 307 055
N02 Remote control unit wireless	0349 304 617
MMA 1 Remote control, 10 m	0349 501 024
MMA 2 Remote control, 10 m	0349 501 025
AT1 Remote control	0459 491 896
AT1 CoarseFine Remote control	0459 491 897
Connection cable 5 m analogue 12 pole	0459 552 880
Connection cable 10 m analogue 12 pole	0459 552 881
Connection cable 15 m analogue 12 pole	0459 552 882
Connection cable 25 m analogue 12 pole	0459 552 883
For remote controls, see page 45-47	

Engine driven welders

Engine driven welders



KHM 190 HS – petrol

A combined engine-driven welding unit and 1ph 230V and 3ph 400V power-generating unit. It allows you to work in environments in which it is difficult or impossible to connect to the mains supply.

Compact and portable, the ESAB KHM 190 HS gives you a combination of 190A strong, high-quality DC welding and up to 6kVA of electric power. All in the same unit. The perfect partner for quick repair or assembly work.

The KHM 190 HS has a Honda petrol engine with a pull start. Other features include: oil alert engine protection, thermal load and residual current device.

Delivery includes

Wrap-around protection frame, single-phase 230 V and three-phase 400 V EEC plugs, OKC

KHM 190 HS	
Setting range, A	20-100, 90-190
Max output at 35% duty cycle, A	190
Max output at 60% duty cycle, A	160
Max output at 100% duty cycle, A	120
Open circuit voltage, V	98
Engine type	Petrol – Honda GX 340 VXB
Sound level, DbA/LWA	73/98
Power, hp/rpm	10/3000
Weight, kg	115

Ordering information

KHM 190 HS	0794 000 880
Trolley	0794 009 880
Earthing kit	0794 017 880
Welding cable	0700 006 890
Return cable	0700 006 889



KHM 190 YS – diesel

This unit has the same performance as the KHM 190 HS, but it has a diesel engine.

A diesel engine is sometimes preferred as it has a much higher flashpoint than petrol and is thereby much safer in terms of combustibility. Diesel can also be stored a couple of years and still be usable.

Diesel engines consume less fuel, at a lower cost for the same power. Diesel engines are also known to have a longer service life. One disadvantage is the higher weight!

The KHM 190 YS has a Yanmar diesel engine with battery and electrical start. Other features include: battery charge indicator, oil alert engine protection, thermal load and residual current device.

Delivery includes

Wrap-around protection frame, single-phase 230 V and three-phase 400 V EEC plugs, OKC

KHM 190 YS	
Setting range, A	20-100, 90-190
Max output at 35% duty cycle, A	190
Max output at 60% duty cycle, A	160
Max output at 100% duty cycle, A	120
Open circuit voltage, V	98
Engine type	Diesel – Yanmar L100AE-DG
Sound level, DbA/LWA	71/96
Power, hp/rpm	40,8/1500
Weight, kg	145

Ordering information

KHM 190 YS	0794 000 882
Trolley	0794 010 880
Earthing kit	0794 017 880
Welding cable	0700 006 890
Return cable	0700 006 889

Engine driven welders

Engine driven welders



KHM 350 YS – CC/CV

The even wider working range together with the opportunity to use semi-automatic welding makes it possible to perform a wide variety of work in environments in which it is difficult or impossible to connect to the mains supply.

Compact and easy to transport, the ESAB KHM 350 YS gives you a combination of 350A strong, high-quality DC (MMA) or 270A 100% (MIG/MAG) welding and up to 12 kVA of electrical power. All in the same unit.

The KHM 350 YS has a water-cooled Yanmar diesel engine with battery and electrical start. Other features include: automatic idle when not in use, an hour meter, battery charge/low fuel/oil pressure indicators, thermal load, arc force, voltmeter, lifting eyelet and residual current device.

Delivery includes

Single-phase 230 V and three-phase 400 V EEC plugs

KHM 350 YS – CC/CV

Setting range, A	20-350
Max output at 35% duty cycle, A	350
Max output at 60% duty cycle, A	320
Max output at 100% duty cycle, A	270
Open circuit voltage, V	65
Engine type	Yanmar 3/TNE 74
Sound level, DbA/LWA	73/98
Power, hp/rpm	22.3/3000
Weight, kg	475

Ordering information

KHM 350 YS – CC/CV	0794 002 880
Remote control	0794 008 880
2 wheels site tow	0794 014 880
Earthing kit	0794 017 880
Welding cable kit	0160 302 881
V/A-meter kit	0794 000 160



KHM 595 PS – CC/CV

Engine driven welding / electric power units for the toughest, professional, heavy-duty repair, maintenance and assembly work. For the toughest environments needing high capacity. The wide working range together with the possibility for carbon arc gouging makes it possible to perform a large variety of work in environments where it is difficult or impossible to connect to the mains supply. KHM 595 PS is equipped with a powerful and efficient, water-cooled Perkins diesel engine with battery and electric start.

KHM 595 is a full multiprocess equipment which can be used in all processes; MMA, TIG and MIG/MAG.

The equipment also have a possibility to give 30 hVA electrical power.

Delivery includes

Single-phase 230V and three-phase 400V EEC plugs, battery without acid and earthing kit

KHM 595 PS – CC/CV

Setting range, A	10-595
Max output at 60% duty cycle, A	550
Max output at 100% duty cycle, A	500
Open circuit voltage, V	60
Engine type	Perkins 1103A – 33G
Sound level, DbA/LWA	71-96
Power, hp/rpm	40,8/1500
Weight, kg	980

Ordering information

Welder KHM 595 PS (50 Hz)	0794 003 883
2 wheel site tow	0794 018 880
PHG1, remote control 20m	0794 008 881
Earthing kit	0794 017 880

TIG equipment

DC



Origo™ Tig 150i/200i

- Sturdy design – stable construction that can withstand rough handling
- Easy-to-use control panel – self-explanatory control panel provides short set-up times
- IP 23 – fit for outdoor use, which makes it safe on all work sites
- TIG welding with HF ignition and LIFTARC™ – you can choose the most suitable arc striking method, always ensuring a safe start procedure

Delivery includes

3 m mains cable with plug, gas hose

Origo™ Tig 150i Origo™ Tig 200i

	Origo™ Tig 150i	Origo™ Tig 200i
Mains supply, V/Hz	230/50-60	230/1 50/60
Fuse, slow, A	16	16
Mains cable, Ø mm ²	2.5	2.5
Max output at 25% duty cycle, A	-	200 (150 MMA)
Max output at 35% duty cycle, A	150	180 (140 MMA)
Max output at 60% duty cycle, A	120	150 (110 MMA)
Max output at 100% duty cycle, A	95	120
Current range TIG DC, A	3-150	3-200
Current range MMA DC, A	4-150	4-150
Open circuit voltage, V	60-75	60-75
Weight, kg	8.2	8.2

Ordering information

Origo™ Tig 150i	0459 200 881
Origo™ Tig 200i	0459 200 883
Origo™ Tig 150i, package (incl. torch)	0459 200 885
Origo™ Tig 200i, package (incl. torch)	0459 200 892
Shoulder strap	0459 368 880
MMA welding and return cable kit 150A ("crocodile")	0349 501 078
MMA welding and return cable kit 150A ("screw")	0349 501 079
MMA welding and return cable kit 200A ("screw")	0700 006 881
For TIG torches, see page 13-15	
For trolleys, see page 44	



Caddy™ Tig 150i/200i

- Practical design – makes the power source easy to carry, which enables use at almost any work site.
- Adjustable slope-down and post-gas – provide a better result at the end of the weld, which means you can avoid cracks and oxidation.
- Two current levels – changing between two levels provides a quick response to gap changes.
- TIG welding with HF ignition and LIFTARC™ – you can choose the most suitable starts, always ensuring a safe start procedure.

Delivery includes

3 m mains cable with plug and gas hose

Caddy™ Tig 150i Caddy™ Tig 200i

	Caddy™ Tig 150i	Caddy™ Tig 200i
Mains supply, V/Hz	230/50-60	230/1 50/60
Fuse, slow, A	16	16
Mains cable, Ø mm ²	2.5	2.5
Max output at 25% duty cycle, A	-	200 (150 MMA)
Max output at 35% duty cycle, A	150	180 (140 MMA)
Max output at 60% duty cycle, A	120	140 (110 MMA)
Max output at 100% duty cycle, A	95	110
Current range TIG DC, A	3-150	3-200
Current range MMA DC, A	4-150	4-150
Open circuit voltage, V	60-75	60-75
Weight, kg	8.9	8.9

Ordering information

Caddy™ Tig 150i	0459 199 881
Caddy™ Tig 150i package	0459 199 885
Caddy™ Tig 200i	0459 199 883
Caddy™ Tig 200i, package	0459 199 890
Shoulder strap	0459 367 880
Trolley small gas bottle	0459 366 880
Trolley large gas bottle	0459 366 881
MMA welding and return cable kit 150A ("crocodile")	0349 501 078
MMA welding and return cable kit 150A ("screw", 3 m)	0349 501 079
MMA welding and return cable kit 200A ("screw")	0700 006 881
Adapter OKC 25-50	0590 046 800
For TIG torches see page 13-15	
For trolleys see page 44	
For remote controls see page 45-47	

TIG equipment

DC



Origo™ Tig 3000i, TA23

The sturdy design makes the Origo™ Tig 3000i suitable for welding anywhere. It is easy to use and reliable in operation.

- Sturdy and robust design – the machine can be brought anywhere where welding needs to be done.
- Easy to use. Basic functionality will produce a TIG weld with high productivity.
- MMA welding. Handles all electrodes up to 5 mm.

Delivery includes

5 m of mains cable, 2 m of gas hose with 2 hose clamps, return cable 4.5 m.

Origo™ Tig 3000i, TA23

Mains supply, V/Hz	400/50-60
Fuse, slow, A	20
Mains cable, Ø mm ²	4x1.5
Max output at 35% duty cycle, TIG, A	300
Max output at 60% duty cycle, TIG, A	240
Max output at 100% duty cycle, TIG, A	200
Slope down, s	0-10
Gas post-flow, s	5-25
Open circuit voltage, V	57-67
Current range TIG DC, A	4-300
Current range MMA DC, A	16-300
Weight, kg	30

Ordering information

Origo™ Tig 3000i, TA23	0459 745 881
Cooling unit, CoolMidi 1800	0459 840 880
For TIG torches see page 13-15	
For trolleys see page 44	
For remote controls see page 45-47	



Origo™ Tig 3000i, TA24

This TIG machine will give a safe start and stable arc. All types of stainless and mild steel and most other materials, from plate thickness of 0.5 mm can be welded with high quality.

- ESAB 2-program function. Possibility to preprogram and change program during welding.
- DC pulsed TIG welding provides easy control of heat input and weld pool.
- Strong and reliable 300 A inverter power-block – one machine for all types of demanding jobs.
- Easy to use. All parameters presented in an easily comprehensible way.
- MMA welding. Handles all electrodes up to 5 mm.

Delivery includes

5 m of mains cable, 2 m of gas hose with 2 hose clamps, return cable 4.5 m.

Origo™ Tig 3000i, TA24

Mains supply, V/Hz	400/50-60
Fuse, slow, A	20
Mains cable, Ø mm ²	4x1.5
Max output at 35% duty cycle, TIG, A	300
Max output at 60% duty cycle, TIG, A	240
Max output at 100% duty cycle, TIG, A	200
Slope up, s	0-10
Slope down, s	0-10
Gas pre-flow, s	0-5
Gas post-flow, s	0-25
Open circuit voltage, V	57-67
Current range TIG DC, A	4-300
Current range MMA DC, A	16-300
Weight, kg	30

Ordering information

Origo™ Tig 3000i, TA24	0459 745 880
Cooling unit, CoolMidi 1800	0459 840 880
For TIG torches see page 13-15	
For trolleys see page 44	
For remote controls see page 45-47	

TIG equipment

DC



Aristo™ Tig 4000i

Outstanding welding characteristics – high efficiency and high-quality welding.

Efficient Man Machine Communication by the user-friendly control panels Aristo™ TA4 and Aristo™ TA6.

TA6 enables a memory of 10 welding parameters and the possibility to weld with the pulse technique, which is especially suitable for thin materials.

- Enclosure class IP 23
- Adjustable pre-gas, slope-up, post-gas and slope-down to control starts and avoid cracks and oxidation at the end
- Dust filter to handle tough and dirty environments and avoid grinding-dust and metal particles inside the chassis

Delivery includes

5 m mains cable incl. plug and return cable with clamp

Aristo™ Tig 4000i

Mains supply, V/Hz	3x400/50-60
Fuse, slow, A	25
Mains cable, Ø mm ²	4x4
Max output at 35% duty cycle, A	400/26 V
Max output at 60% duty cycle, A	320/23 V
Max output at 100% duty cycle, A	250/20 V
Slope up, s	0-5
Slope down, s	0-10
Gas pre-flow, s	0-5
Gas post-flow, s	0-200
Open circuit voltage, V	78-90
Setting range, A	4-400
Weight, kg	59

Ordering information

Aristo™ Tig 4000i TA4	0458 630 880
Aristo™ Tig 4000i TA6	0458 630 884
Aristo™ Tig 4000iw TA4 with water-cooling unit	0458 630 881
Aristo™ Tig 4000iw TA6 with water-cooling unit	0458 630 885
For trolleys, see page 44	
For remote controls, see page 45-47	
For multi-voltage unit, see page 43	

AC/DC



Caddy™ Tig 2200i AC/DC

The Caddy™ is already a classic power source in the mobile welding equipment field. With Caddy™ Tig 2200i AC/DC you will get a machine with low weight as well as a small footprint and an easy to use control panel. It will give an excellent arc strike and consistent, stable arc. All types of material and thickness up to 5 mm can be welded with the highest quality.

Delivery includes

3 m of mains cable, 2 m of gas hose with 2 hose clamps, return cable 4,5 m.

	Caddy™ Tig 2200i AC/DC, TA34 AC/DC	Caddy™ Tig 2200i AC/DC, TA33 AC/DC
--	------------------------------------	------------------------------------

Mains supply, V/Ph	230/1 50Hz	230/1 50Hz
Setting range TIG AC/DC	4-220	4-220
Setting range MMA	16-160	16-160
Max output at 20% duty cycle, TIG, A/V	220/18.	220/18.
Max output at 60% duty cycle, TIG, A/V	150/16.0	150/16.0
Max output at 100% duty cycle, TIG, A/V	140/15.6	140/15.6
Weight, kg	5/7	5/7
External dimension, mm l x w x h	407x187x137	407x187x137

Ordering information

Caddy™ Tig 2200i AC/DC, TA33 AC/DC TXH™ 200 4m MMA Kit	0460 150 882
Caddy™ Tig 2200i AC/DC, TA34 AC/DC TXH™ 200 4m MMA Kit	0460 150 883
Caddy™ Tig 2200i AC/DC, TA34 AC/DC TXH™ 250w 4m, water cooler CoolMini MMA kit Two wheel trolley	0460 150 884
Caddy™ Tig 2200i AC/DC, TA34 AC/DC	0460 150 880
Caddy™ Tig 2200i AC/DC, TA33 AC/DC	0460 150 881
Cooling unit, CoolMini	0460 144 880
For TIG torches, see page 13-15	
For trolleys, see page 44	
For remote controls, see page 45-47	

TIG equipment

AC/DC



Origo™ Tig 3000i AC/DC, TA24 AC/DC

In both DC and AC mode this TIG welding machine will give an excellent start and stable arc. All type of material and thickness can be welded with the highest quality.

- Designed for quality TIG-welding in all types of material.
- QWave™ - enables AC welding with high arc stability and low noise.
- AC frequency and balance control optimizes weld pool.
- DC pulsed TIG welding gives easy control of heat input.
- ESAB 2-program function. Possibility to pre-program and change program during welding.
- Easy to use. All parameters presented in an easily comprehensible way.
- MMA welding. Hot start, arc force and polarity switch.

Delivery includes

5 m of mains cable, 2 m of gas hose with 2 hose clamps, return cable 4.5 m.

Origo™ Tig 3000i AC/DC, TA24 AC/DC

Mains supply, V/Hz	400/50-60
Fuse, slow, A	20
Mains cable, Ø mm ²	4x2.5
Max output at 35% duty cycle, TIG, A	300
Max output at 60% duty cycle, TIG, A	240
Max output at 100% duty cycle, TIG, A	200
AC balance, %	50-98
Slope up, s	0-10
Slope down, s	0-10
Gas post-flow, s	0-25
Open circuit voltage, V	54-64
Setting range TIG AC/DC, A/V	4-300
Setting range, A	16-300
Weight, kg	42

Ordering information

Origo™ Tig 3000i AC/DC, TA24 AC/DC	0459 735 880
Cooling unit, CoolMidi 1800	0459 840 880
For TIG torches see page 13-15	
For trolleys see page 44	
For remote controls see page 45-47	



Origo™ Tig 4300iw AC/DC, TA24 AC/DC

- Designed for quality TIG-welding in all types of material.
- QWave™ - enables AC welding with high arc stability and low noise.
- AC Frequency and Balance control- Optimises weld pool
- DC Pulsed TIG welding- easy control of heat input and the weld pool.
- ESAB LogicPump – ELP, automatic start of the cooling unit by connection of a liquid-cooled torch
- Energy save mode – fan and pump on demand
- ESAB 2-program function -possibility to pre-program and change program during actual welding.
- Easy to use- All welding parameters presented in an easy to understand panel.
- MMA welding in AC and DC mode – Hot start, Arc force, and polarity switch (DC).

Delivery includes

5 m mains cable incl plug, 2 m gas hose incl. 2 hose clamps and return cable 5 m incl earth clamp.

Origo™ Tig 4300iw AC/DC, TA24 AC/DC

Mains supply, V/Ph	400/3
Setting range TIG AC/DC	4-430
Setting range MMA	16-430
Max output at 40% duty cycle, TIG, A/V	430/27.2
Max output at 60% duty cycle, TIG, A/V	400/26
Max output at 100% duty cycle, TIG, A/V	315/22.6
External dimensions mm, l x w x h	625x394x776
Weight, kg incl. cooling unit	95

Ordering information

Origo™ Tig 4300iw AC/DC, TA24 AC/DC	0460 100 880
For TIG torches see page 13-15	
For trolleys see page 44	
For remote controls see page 45-47	
For multi-voltage unit, see page 43	

TIG equipment

Torches and components



Tigaid 315 AC/DC

The Tigaid 315 AC/DC is a useful tool for converting MMA machines, transformers and rectifiers for TIG applications. Tigaid controls the supply of current, HF ignition and gas flow. When steplessly and electronically-controlled MMA power sources are used, it is possible to obtain current setting and slope functions.

Tigaid 315

Mains supply, V/Hz	230/50-60
Fuse, slow, A	10
Mains cable, Ø mm ²	3x1.5
Max output at 35% duty cycle, A	315
Slope up, s	0.1-10
Slope down, s	0.1-10
Gas pre-flow, s	0.1-5.0
Gas post-flow, s	1.0-60
Weight, kg	15

Ordering information

Tigaid 315 AC/DC, 110/220/240 V, 50/60 Hz, OKC-connection	0369 136 882
Connection kit for self-cooled torch and power source with remote control socket type Burndy	0467 348 880
Connection kit for water-cooled torch and power source with Burndy socket	0467 348 881
Connection kit for air-cooled torch and welding transformer	0467 348 882

TXH™ 120, 120V, 120F

The major characteristic for the TXH™ torch program is its quality. The torches and torch outfits are designed to provide the utmost in convenience, versatility and ergonomics.

They are air-cooled, with or without gas valve and with or without a flexible neck. It all depends on the job.

120 A torch with start switch – small size and perfect access in confined areas.

Built-in gas valve for manual control of the shielding gas by hand (model V).

Flexible heads offer unlimited versatility for reaching hard-to-get-at applications (model with F).

Ordering information

TXH™ 120, OKC 4 m	0460 010 842
TXH™ 120, OKC 8 m	0460 010 882
TXH™ 120V, OKC25 4 m	0460 010 841
TXH™ 120V, OKC25 8 m	0460 010 881
TXH™ 120F, OKC 4 m	0460 010 844
TXH™ 120F, OKC 8 m	0460 010 884
TXH™ 120, OKC25 4 m*	0460 010 940
TXH™ 120, OKC25 8 m*	0460 010 980
TXH™ 120, OKC25C 4 m**	0460 010 840
TXH™ 120, OKC25C 8 m**	0460 010 880

* Only Origo™ Tig 150i

** Only Caddy™ Tig 150i

TIG equipment

Torches and components



TXH™ 150, 150V, 150F

The major characteristic for the TXH™ torch program is its quality. The torches and torch outfits are designed to provide the utmost in convenience, versatility and ergonomics.

They are air-cooled, with or without gas valve and with or without a flexible neck. It all depends on the job.

Effective cooling – small size and perfect access in confined areas.

Rugged construction – trouble-free operation with low maintenance.

Built-in gas valve for manual control of the shielding gas by hand (model V).

Flexible heads offer unlimited versatility for reaching hard-to-get-at applications (model with F).

Ergonomic handle.

Ordering information

TXH™ 150, OKC 4 m	0460 011 842
TXH™ 150, OKC 8 m	0460 011 882
TXH™ 150V, OKC 4 m	0460 011 843
TXH™ 150V, OKC 8 m	0460 011 883
TXH™ 150F, OKC 4 m	0460 011 845
TXH™ 150F, OKC 8 m	0460 011 885
TXH™ 150, OKC25 4 m*	0460 011 940
TXH™ 150, OKC25 8 m*	0460 011 980
TXH™ 150, OKC25C 4 m**	0460 011 840
TXH™ 150, OKC25C 8 m**	0460 011 880

* Only Origo™ Tig 150i

** Only Caddy™ Tig 150i



TXH™ 200, 200V, 200F

The major characteristic for the TXH™ torch program is its quality. The torches and torch outfits are designed to provide the utmost in convenience, versatility and ergonomics.

They are air-cooled with or without gas valve and with or without a flexible neck. It all depends on the job.

Effective cooling – small size and perfect access in confined areas.

Rugged construction – trouble-free operation with low maintenance.

Built-in gas valve for manual control of the shielding gas by hand (model V).

Flexible heads offer unlimited versatility for reaching hard-to-get-at applications (model F).

Ergonomic handle.

Ordering information

TXH™ 200, OKC 4 m	0460 012 840
TXH™ 200, OKC 8 m	0460 012 880
TXH™ 200V, OKC 4 m	0460 012 841
TXH™ 200V, OKC 8 m	0460 012 881
TXH™ 200F, OKC 4 m	0460 012 842
TXH™ 200F, OKC 8 m	0460 012 882

TIG equipment

Torches and components



TXH™ 250w, 250wF, 400w, 400w HD

The major characteristic for the TXH™ torch program is its quality. The torches and torch outfits are designed to provide the utmost in convenience, versatility and ergonomic.

These are water-cooled, with or without a flexible neck. It all depends on the job.

Effective cooling – small size and perfect access in confined areas (TXH™ 250w).

Rugged construction – trouble-free operation with low maintenance.

Built-in gas valve for manual control of the shielding gas by hand (model V).

Flexible heads offer unlimited versatility for reaching hard-to-get-at applications (model F). (TXH™ 250w)

Ergonomic handle.

The HD is a model in the TXH™ range to match Origo™ 4300iw AC/DC.

Ordering information

TXH™ 250w, OKC 4 m	0460 013 840
TXH™ 250w, OKC 8 m	0460 013 880
TXH™ 250wF, OKC 4 m	0460 013 841
TXH™ 250wF, OKC 8m	0460 013 881
TXH™ 400w, OKC 4 m	0460 014 840
TXH™ 400w, OKC 8 m	0460 014 880
TXH™ 400w HD, OKC 4 m	0460 014 841
TXH™ 400w HD, OKC 8 m	0460 014 881

TXH™ remote torches

With the TXH range with remote it is possible to adjust the welding current during welding and between welds with two buttons in the handle marked with + and -.

TXH range with remote will have torch with the +/- buttons and an adapter to connect the torch to all ESAB CAN-bus controlled machines. Adapter must only be bought once and all the different torches fit to the same adapter.

Ordering information

TXH™ 120r, OKC 4 m	0462 010 842
TXH™ 120r, OKC 8 m	0462 010 882
TXH™ 120Fr, OKC 4 m	0462 010 844
TXH™ 120Fr, OKC 8 m	0462 010 884
TXH™ 150r, OKC 4 m	0462 011 842
TXH™ 150r, OKC 8 m	0462 011 882
TXH™ 150Fr, OKC 4 m	0462 011 845
TXH™ 150Fr, OKC 8 m	0462 011 885
TXH™ 200r, OKC 4 m	0462 012 840
TXH™ 200r, OKC 8 m	0462 012 880
TXH™ 200Fr, OKC 4 m	0462 012 842
TXH™ 200Fr, OKC 8 m	0462 012 882
TXH™ 250wr, OKC 4 m	0462 013 840
TXH™ 250wr, OKC 8 m	0462 013 880
TXH™ 250wFr, OKC 4 m	0462 013 841
TXH™ 250wFr, OKC 8 m	0462 013 881
TXH™ 400wr, OKC 4 m	0462 014 840
TXH™ 400wr, OKC 8 m	0462 014 880
TXH™ 400wr HD, OKC 4 m	0462 014 841
TXH™ 400wr HD, OKC 8 m	0462 014 881
Remote adapterkit incl. holder and 0,25 m cable	0459 491 912

TIG equipment

Torches and components

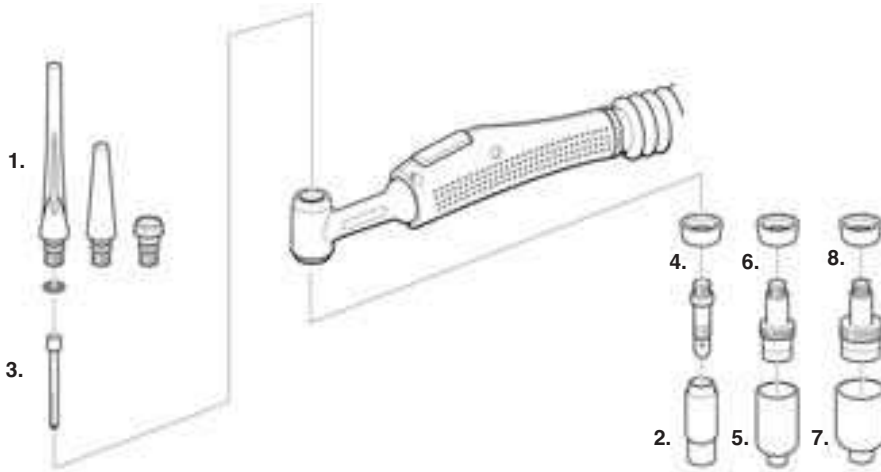

Tungsten electrodes

	W L = 150	W L = 175
1.0 mm	0151 574 208	0151 574 008
1.6 mm	0151 574 209	0151 574 009
2.0 mm	0151 574 245	-
2.4 mm	0151 574 210	0151 574 010
3.2 mm	0151 574 211	0151 574 011
4.0 mm	0151 574 212	0151 574 012
4.8 mm	-	-

	WT20 L = 150	WT20 L = 175
1.0 mm	0151 574 201	0151 574 001
1.6 mm	0151 574 202	0151 574 002
2.0 mm	0151 574 244	-
2.4 mm	0151 574 203	0151 574 003
3.2 mm	0151 574 204	0151 574 004
4.0 mm	0151 574 205	0151 574 005
4.8 mm	-	-

	WC20 L = 150	WC20 L = 175
1.0 mm	0151 574 236	0151 574 036
1.6 mm	0151 574 237	0151 574 037
2.0 mm	0151 574 242	-
2.4 mm	0151 574 238	0151 574 038
3.2 mm	0151 574 239	0151 574 039
4.0 mm	0151 574 240	0151 574 040
4.8 mm	-	-

	GoldPlus L = 150	GoldPlus L = 175
1.0 mm	0151 524 230	0151 574 050
1.6 mm	0151 524 231	0151 574 051
2.0 mm	0151 524 232	-
2.4 mm	0151 524 233	0151 574 052
3.2 mm	0151 524 234	0151 574 053
4.0 mm	0151 524 235	0151 574 054
4.8 mm	-	0151 574 055

Dimension (mm) Eco

	General example	TXH™ 120/250w	TXH™ 150/200	TXH™ 400w/400w HD
1.	Long	0365 310 051	0157 123 029	0157 123 029
	Medium	0365 310 050	0588 000 591	0588 000 591
	Short	0365 310 049	0157 123 028	0157 123 028
2.	Ø 6.4	0365 310 044	0157 123 052	0157 123 057
	Ø 8.0	0365 310 045	0157 123 053	0157 123 058
	Ø 9.8	0365 310 046	0157 123 054	0157 123 059
	Ø 11.2	0365 310 047	0157 123 055	0157 123 060
	Ø 12.7	0365 310 048	0157 123 056	0157 123 061
	Ø 15.9	0588 000 440	0558 000 442	-
	Ø 19	-	0558 000 441	-
3.	Ø 1.0	0365 310 028	0157 123 010	0157 123 010
	Ø 1.6	0365 310 029	0157 123 011	0157 123 011
	Ø 2.4	0365 310 030	0157 123 012	0157 123 077
	Ø 3.2	0365 310 091	0157 123 013	0157 123 078
	Ø 4.0	-	0157 123 014	0157 123 079
	Ø 4.8	-	-	0157 123 074
	Ø 4.0-4.8	0366 960 017	0366 960 016	0366 960 018
4.	Ø 1.0	0365 310 037	0157 123 015	0157 123 081
	Ø 1.6	0365 310 038	0157 123 016	0157 123 081
	Ø 2.4	0365 310 039	0157 123 017	0157 123 081
	Ø 3.2	0365 310 090	0157 123 018	0157 123 082
	Ø 4.0-4.8	-	0157 123 019	0157 123 082
	Ø 4.0-4.8	0366 960 017	0366 960 016	0366 960 018
	Ø 4.0-4.8	0366 960 017	0366 960 016	0366 960 018
5.	Ø 6.4	0157 121 032	0157 123 057	0157 123 057
	Ø 8.0	0157 121 033	0157 123 058	0157 123 058
	Ø 9.8	0157 121 034	0157 123 059	0157 123 059
	Ø 11.2	0157 121 039	0157 123 060	0157 123 060
	Ø 12.7	0157 121 040	0157 123 061	0157 123 061
	Ø 17.5	-	0588 000 439	0588 000 439
	Ø 17.5	-	0588 000 439	0588 000 439
6.	Ø 1.0	0157 121 016	0157 123 021	-
	Ø 1.6	0157 121 017	0157 123 022	0157 123 092
	Ø 2.4	0157 121 018	0157 123 023	0157 123 093
	Ø 3.2	0157 121 041	0157 123 024	0157 123 094
	Ø 4.0	-	0157 123 025	0157 123 095
	Ø 4.8	-	-	0157 123 075
	Ø 4.0-4.8	-	0366 960 020	0366 960 018
	Ø 4.0-4.8	-	0366 960 020	0366 960 018
7.	Ø 9.8	-	0157 123 088	0157 123 088
	Ø 12.7	-	0157 123 089	0157 123 089
	Ø 15.9	-	0588 000 438	0588 000 438
	Ø 19	-	0157 123 098	0157 123 098
	Ø 24	-	0588 000 437	0588 000 437
	Ø 24	-	0588 000 437	0588 000 437
8.	Ø 2.4	0157 123 085	-	-
	Ø 3.2	-	0157 123 086	-
	Ø 4.0-4.8	-	0157 123 087	-
	Ø 4.0-4.8	-	0366 960 021	-

MIG/MAG equipment

Compacts



Origo™ Mag C140/C150/C170/C200/C250

- Power Smoothing Device™ – excellent welding performance for single phase machines.
- Easy change of polarity – can be used with both conventional solid wire and self-shielding cored wire.
- Easy setting of welding parameters – welding machines for everyone.
- MXL™ Torches – designed to provide the utmost in convenience and versatility.

Delivery includes

Origo Mag C140/C150: Welding torch MXL 150V 2.5 m (contact tip 0.8) assembled feed roller 0.6-0.8. Origo Mag C170/C200: MXL 200 3 m (contact tip 0.8) assembled feed roller 0.6-0.8. Origo Mag C250: MXL 270 3 m (contact tip 1.0) assembled feed roller 0.8-1.0. All units: 3 m mains cable with plug, 3 m return cable with clamp, gas hose 1.5 m, shelf for gas cylinder (except for Origo Mag C140) and attachment chain for gas cylinder.

	C140	C150	C170	C200	C250
Mains supply, V/Hz	230 1ph 50/60	230 1ph 50/60	230 1ph 50/60	230 1ph 50/60	230 1ph 50/60
Max output at 20% duty cycle, A	100	150	170	200	250
Max output at 30% duty cycle, A	-	122	139	163	200
Max output at 60% duty cycle, A	54	86	98	115	140
Max output at 100% duty cycle, A	42	67	76	90	110
Wire feed, m/min	2.0-14	2.0-14	1.0-17	1.0-17	1.9-19
Open circuit voltage, V	20-28	18.5-30.5	19.5-35.5	17.5-33	19.5-42.5
Weight, kg	25	37.5	59	68	94

Ordering information

Origo™ Mag C140 (230V 1 ph 50/60 Hz)	0349 306 220
Origo™ Mag C150 (230V 1 ph 50/60 Hz)	0349 306 532
Origo™ Mag C170 (230V 1 ph 50/60 Hz)	0349 305 236
Origo™ Mag C200 (230V 1 ph 50/60 Hz)	0349 306 560
Origo™ Mag C250 (230V 1 ph 50/60 Hz)	0349 305 238
Digital instrument (Origo™ Mag C170, C200, C250)	0349 302 598
Transformer for CO ₂ heater	0349 302 250
Wheel KIT (Origo™ Mag C140)	0349 309 073



Origo™ Mig C170 3ph/C200 3ph/C250 3ph

The Origo™ Mig C170 3ph/C200 3ph/C250 3ph are three-phase step regulated welding power sources for MIG/MAG welding. A built-in wire feeder and the low weight of the units make them perfect, practical solutions for farmers, repair shops and light production users.

Delivery includes

Origo™ Mig C170/C200 3ph: MXL™ 200 3 m (contact tip 0.8) assembled feed roller 0.6-0.8. Origo™ Mig C250 3ph: MXL™ 270 3 m (contact tip 1.0) assembled feed roller 0.8-1.0. All units: 3 m mains cable with plug, 3m return cable with clamp, gas hose 1.5 m, shelf for gas cylinder and attachment chain for gas cylinder.

	C170 3ph	C200 3ph	C250 3ph
Mains supply, V/Hz	400-415 3ph 50/60	400-415 3ph 50/60	230/400-415 3ph 50/60
Max output at 35% duty cycle, A	170	200	250
Max output at 60% duty cycle, A	130	150	190
Max output at 100% duty cycle, A	100	120	150
Wire feed, m/min	1-17	1-17	1-17
Interval/spot welding			
Open circuit voltage, V	15.5-30.6	16-31.8	15-37
Weight, kg	63.5	72.5	82

Ordering information

Origo™ Mig C170 3ph (400-415V 3ph 50/60 Hz)	0349 308 670
Origo™ Mig C200 3ph (400-415V 3ph 50/60 Hz)	0349 308 290
Origo™ Mig C250 3ph (400-415V 3ph 50/60 Hz)	0349 307 840
Origo™ Mig C250 3ph (230/400-415V 3ph 50/60 Hz)	0349 309 090
Digital instrument	0349 302 598
Transformer for CO ₂ heater (42V 50/60 Hz)	0349 302 250
Polarity change KIT (Origo™ Mig C170)	0349 309 310

MIG/MAG equipment

Compacts



Origo™ Mig C240 PRO/ C240s PRO

- Outstanding welding characteristics – high efficiency and high-quality welding.
- Sturdy galvanised metal casing with an air filter as an option – made to withstand tough corrosive and dirty environments.
- Wide current and voltage range – multi-purpose applications
- Two inductance outlets – easy to optimise settings for different applications.

Delivery includes

Welding torch PSF™ 250 3 m, 5 m mains cable with plug, 3.5 m return cable with clamp, gas hose 1.5 m, shelf for gas cylinder, attachment chain for gas cylinder, assembled feed rollers 0.8-1.0 for Fe, Ss and cored wire.

	C240 PRO	C240s PRO
Mains supply, V/Hz	400-415, 50/60 230/50-60	400-415, 50/60 230/50-60
Max output at 30% duty cycle, A	240	240
Max output at 60% duty cycle, A	170	170
Max output at 100% duty cycle, A	130	130
Wire feed, m/min	1.9-19	1.4-19
Interval/spot welding	0.2-2.5	0.5-4.0
Open circuit voltage, V	14-32	14-32
Weight, kg	103	100

Ordering information

Origo™ Mig C240 PRO (400-415 V, 50/60 Hz)	0349 304 657
Origo™ Mig C240 PRO (230 V, 50/60 Hz)	0349 304 658
Origo™ Mig C240s PRO (400-415 V, 50/60)*	0349 304 659
Origo™ Mig C240s PRO (230 V, 50/60)*	0349 304 660
Air filter	0349 302 599
Digital instrument	0349 302 598
Transformer for CO ₂ heater	0349 302 250
Cable holder	0349 303 362

* digital instrument included as standard



Origo™ Mig C280 PRO/C340 PRO

The Origo™ Mig C280 PRO/C340 PRO are step-regulated compact power sources for MIG/MAG welding. They are designed for light- to medium-duty applications.

The Origo™ Mig C280 PRO is a 10 voltage-step unit. The operator can adjust wire-feed speed, burnback time and spot-welding time.

The Origo™ Mig C340 PRO is a 40 voltage-step unit. The operator can adjust wire-feed speed and select 2- or 4-stroke control and creep start.

Delivery includes

Welding torch PSF 250 3 m (for C280 PRO), PSF 250 4.5 m (for C280 PRO 4WD), PSF 305 3 m (for C340 PRO), PSF 305 4.5 m (for C340 PRO 4WD), 5 m mains cable, wheels, 3.5 m return cable (5 m for 4WD) with clamp and shelf for gas cylinder.

	C280 PRO	C340 PRO
Mains supply, V/Hz	400-415 50/60*	400-415 50/60*
Max output at 30% duty cycle, A	280	340
Max output at 60% duty cycle, A	190	250
Max output at 100% duty cycle, A	150	195
Wire feed, m/min	1.9-19	1.9-20
Wire Ø, unall. solid	0.6-1.0	0.6-1.2
Wire Ø, SS	0.6-1.0	0.6-1.2
Wire Ø, Al	1.0-1.2	1.0-1.2
Wire Ø, CW	1.0-1.2	1.0-1.2
Interval/spot welding	0.2-2.5	-
Open circuit voltage, V	15-38	16-40
Weight, kg	97	120

Ordering information

Origo™ Mig C280 PRO (400-415 V, 50/60 Hz)	0349 302 889
Origo™ Mig C280 PRO*	0349 302 844
Origo™ Mig C280 PRO 4WD (400-415 V, 50/60 Hz)	0349 302 890
Origo™ Mig C280 PRO 4WD*	0349 302 612
Origo™ Mig C340 PRO (400-415 V, 50/60 Hz)	0349 302 452
Origo™ Mig C340 PRO*	0349 302 483
Origo™ Mig C340 PRO 4WD (400-415 V, 50/60 Hz)	0349 302 484
Origo™ Mig C340 PRO 4WD*	0349 302 485
Air filter	0349 302 599
Digital instrument	0349 302 598
Transformer for CO ₂ heater	0349 302 250
Cable holder	0349 303 362

*230/400-415/500 V, 50 Hz; 230/440-460 V, 60 Hz

MIG/MAG equipment

Compacts



Origo™ Mig C420 PRO

The Origo™ Mig C420 PRO is a step-regulated compact power source for MIG/MAG welding. It is designed for heavy-duty applications.

The Origo™ Mig C420 PRO is a 35 voltage-step unit. The operator can adjust wire-feed speed, burnback time and select 2- or 4-stroke control.

Delivery includes

Welding torch PSF™ 405/PSF™ 410w 4.5 m, 5 m mains cable with plug, 5 m return cable with clamp, gas hose 1.5 m, shelf for gas cylinder and attachment chain for gas cylinder.



C420 PRO

Mains supply, V/Hz	400-415/50/60
Max output at 50% duty cycle, A	420
Max output at 60% duty cycle, A	400
Max output at 100% duty cycle, A	315
Wire feed, m/min	1.9-25
Wire Ø, unall. solid	0.6-1.6
Wire Ø, SS	0.6-1.6
Wire Ø, Al	0.8-1.6
Wire Ø, CW	0.9-1.6
Interval/spot welding	-
Open circuit voltage, V	14-47
Weight, kg	215

Ordering information

Origo™ Mig C420w PRO (400-415 V, 50/60 Hz)	0349 303 079
Origo™ Mig C420 PRO (400-415 V, 50/60 Hz)	0349 302 655
Air filter	0349 302 252
Digital instrument	0349 302 451
Transformer for CO ₂ heater	0349 302 250
Water flow guard	0349 302 251
Cable holder	0349 303 362

MIG/MAG equipment

Semi-automats



Origo™ Mig L305/L405

The Origo™ Mig L305/L405 welding package is ideal for welding applications within auto repair workshop, general steel fabrication, the vehicle industry and household and furniture manufacturers.

The package consists of the Origo™ Mig L305/L405 power source, Origo™ Feed L302 or L304 wire feed units, a connection set and the PSF™ welding torch.

- 40 voltage steps optimum settings for each application. (L405)
- Two inductance outlets – easy to optimise settings for different applications.
- IP 23 – fit for safe out of doors applications.
- Easy-to-use panel for quick set up.

Delivery includes

5 m mains cable, wheels, return cable with clamp, gas bottle platform and a guide pin for the wire feeder.

	Origo™ Mig L305	Origo™ Mig L405
Mains supply, V/Hz	400/415, 3~ 50	400/415, 3~ 50, 230/400-415/500, 3~ 50; 230/400-460, 3~ 60
Fuse, slow, A	16	20
Mains cable, Ø mm ²	4x2.5	4x2.5
Max output at 25% duty cycle, A/V	300/29	
Max output at 50% duty cycle, A/V		400/34
Max output at 60% duty cycle, A/V	190/24	365/32
Max output at 100% duty cycle, A/V	150/22	280/28
Open circuit voltage, V	17-40	17-45
Weight, kg	89	142

Ordering information

Origo™ Mig L305 (400-415V 50Hz)	0349 309 700
Origo™ Mig L405 (400-415V 50Hz)	0349 306 517
Origo™ Mig L405 (230/400-415&500V 50Hz; 230/440-460V 60Hz)	0349 306 594
Origo™ Mig L405w (400-415V 50Hz)	0349 306 563



Origo™ Mig L405w (230/400-415/500V 50Hz; 230/440-460V 60Hz)

Connection cable 1.7 m, 50 mm ² *	0349 306 595
Connection cable 5.0 m, 50 mm ²	0459 532 880
Connection cable 5.0 m, 50 mm ² , water-cooled	0459 532 881
Connection cable 10.0 m, 50 mm ²	0459 532 891
Connection cables 10.0 m, 50 mm ² , water-cooled	0459 532 882
PSF™ 305 3 m	0459 532 892
PSF™ 305 4.5 m	0458 401 880
PSF™ 405 3 m	0458 401 881
PSF™ 405 4.5 m	0458 401 882
PSF™ 410w 3 m	0458 401 883
PSF™ 410w 4.5 m	0458 400 882
Accessories	0458 400 883

Digital instrument (for Origo™ Mig L305)	0349 302 598
Digital instrument (for Origo™ Mig L405)	0349 302 451
Transformer for CO ₂ heater	0349 302 250
Stabilizer (for Origo™ Mig L305)	0349 303 475
Stabilizer (for Origo™ Mig L405)	0349 303 474
Reinforcer kit for counterbalance	0349 309 748

* Connection cable 1.7 m item no. 0459 532 880 combined with Feed L304w provides a complete water-cooled solution.

For wire feeders, see page 26-31

For interconnection cables, see page 33

MIG/MAG equipment

Semi-automats



Origo™ Mig 320

The Origo™ Mig 320 is a step-regulated power source for MIG/MAG welding. It is designed for medium-duty applications. It is a 40 voltage-step unit and it has two inductance outlets. Strong, galvanised metal casing makes this unit the perfect solution for harsh environments. Wide voltage and current range optimise settings for various applications.

As an option, the unit can be equipped with digital instruments. The large wheels, sturdy lifting eyelets and an under carriage designed for transportation with fork-lifts make the unit easy to move. The Origo™ Mig 320 operates with the separate wire feeders Origo™ FeedAirmatic, Origo™ Feed 302 M11, 304 M12 and 484 M12 and Origo™ YardFeed 200 (without V/A meter).

Delivery includes

5 m mains cable, wheels, 5 m return cable with clamp, shelf for gas cylinder and a guide pin for the wire feeder.

Origo™ Mig 320

Mains supply, V/Hz	400-415, 3~50/60
Fuse, slow, A	20-16
Mains cable, Ø mm ²	4x2.5
Max output at 30% duty cycle, A	320
Max output at 60% duty cycle, A	250
Max output at 100% duty cycle, A	195
Setting range, A	40-320
Open circuit voltage, V	16-40
Weight, kg	111

Ordering information

Origo™ Mig 320 (400-415 V, 50/60 Hz)	0349 302 676
Origo™ Mig 320 (400-415 V, 50/60 Hz) with digital instrument	0349 303 562
Origo™ Mig 320*	0349 302 613
Air filter	0349 302 599
Cable holder	0349 303 362
Digital instrument	0349 302 598
Transformer for CO ₂ heater	0349 302 250
Stabilizer	0349 303 475
*230/400-415/500 V, 50 Hz; 230/440-460 V, 60 Hz	
Multivoltage version available on request	
For wire feeders, see page 26-31	



Origo™ Mig 410/510

The Origo™ Mig 410 and 510 are step-regulated power sources for MIG/MAG welding designed for heavy-duty applications.

They are 40 voltage-step units available as water- or air-cooled versions. The Origo™ Mig 410 has two inductance outlets, while the Origo™ Mig 510 has three inductance outlets. Origo™ Mig 410/510 operates with the separate wire feeders Origo™ FeedAirmatic, Origo™ Feed 302 M11, 304 M12 and 484 M12 and Origo™ YardFeed 200 (without V/A meter).

Delivery includes

5 m mains cable, wheels, 5 m cable with clamp, shelf for gas cylinder and a guide pin for wire feeder.

Origo™ Mig 410 Origo™ Mig 510

Mains supply, V/Hz	400-415, 3~50/60	400-415, 3~50/60
Fuse, slow, A	25-20	50-35
Mains cable, Ø mm ²	4x2.5	4x6
Max output at 50% duty cycle, A	400	-
Max output at 60% duty cycle, A	365	500
Max output at 100% duty cycle, A	280	390
Open circuit voltage, V	17-45	17-50
Weight, kg	144	214

Ordering information

Origo™ Mig 410 (400-415 V, 50/60 Hz)	0349 302 408
Origo™ Mig 410*	0349 302 713
Origo™ Mig 410w (400-415 V, 50/60 Hz)	0349 302 407
Origo™ Mig 410w*	0349 302 711
Origo™ Mig 410 (400-415 V, 50/60 Hz) with digital instrument	0349 303 563
Origo™ Mig 410w (400-415 V, 50/60 Hz) with digital instrument	0349 303 564
Origo™ Mig 510 (400-415 V, 50/60 Hz)	0349 302 404
Origo™ Mig 510*	0349 302 436
Origo™ Mig 510w (400-415 V, 50/60 Hz)	0349 302 403
Origo™ Mig 510w*	0349 302 435
Origo™ Mig 510 (400-415 V, 50/60 Hz) with digital instrument	0349 303 565
Origo™ Mig 510w (400-415 V, 50/60 Hz) with digital instrument	0349 303 566
Air filter	0349 302 423
Cable holder	0349 303 362
Digital instrument (for Origo™ Mig 410)	0349 302 451
Digital instrument (for Origo™ Mig 510)	0349 302 424
Water flow guard	0349 302 251
Transformer for CO ₂ heater	0349 302 250
Stabilizer	0349 303 474
Reinforcer kit for counterbalance	0349 309 748
*230/400-415/500 V, 50 Hz; 230/440-460 V, 60 Hz	
Multivoltage version available on request. For wire feeders, see page 26-31	

MIG/MAG equipment

Semi-automats



Origo™ Mig 400t/500t

The Origo™ Mig 400t and 500t are thyristor power sources for MIG/MAG welding. They are designed for heavy-duty applications. The units are available as water- or air-cooled versions. Wide voltage and current range and three inductance outlets make it easy to optimise settings for various applications. Strong, galvanised metal casing makes these units the perfect solution for harsh environments. The Origo™ Mig 400t/500t operates with the separate wire feeders Origo™ FeedAirmatic, Origo™ Feed 304/484 M13 and Origo™ YardFeed 200.

Delivery includes

5 m mains cable, wheels, return cable with clamp, shelf for gas cylinder and a guide pin for the wire feeder.

Origo™ Mig 400t Origo™ Mig 500t

	Origo™ Mig 400t	Origo™ Mig 500t
Mains supply, V/Hz	400-415/50, 230/400-415/500, 50Hz; 230/440-460, 60Hz	400-415/50, 230/400-415/500, 50Hz; 230/440-460, 60Hz
Fuse, slow, A	25	35
Mains cable, Ø mm ²	4x4	4x6
Max output at 45% duty cycle, A	400	-
Max output at 60% duty cycle, A	350	500
Max output at 100% duty cycle, A	280	400
Setting range, A	50-400	50-500
Open circuit voltage, V	53-58	53-60
Weight, kg	209	235

Ordering information

Origo™ Mig 400t (400-415 V 50 Hz)	0349 302 242
Origo™ Mig 400t*	0349 302 243
Origo™ Mig 400tw (400-415 V 50 Hz)	0349 302 244
Origo™ Mig 400tw*	0349 302 245
Origo™ Mig 500t (400-415 V 50 Hz)	0349 302 246
Origo™ Mig 500t*	0349 302 247
Origo™ Mig 500tw (400-415 V 50 Hz)	0349 302 248
Origo™ Mig 500tw*	0349 302 249
Digital instrument	0455 173 882
Transformer for CO ₂ heater	0349 302 250
Air filter	0349 302 252
Water flow guard	0349 302 251
Cable holder	0349 303 362

*230/400-415/500 V 50 Hz; 230/440-460 V 60 Hz

Multivoltage version available on request

For wire feeders, see page 26-31



Origo™ Mig 630t MAGMA

- A power source for MIG/MAG, MMA welding and air-arc gouging – a cost-effective combination.
- Sturdy galvanised metal casing with an air filter as an option – made to withstand tough corrosive and dirty environments.
- Mains voltage compensation – stable welding controls.
- Stepless voltage control – exact settings and remote-control facilities
- Built-in water cooler
- ELP, ESAB LogicPump – automatically starts the water pump when a water-cooled torch is connected
- The Origo™ Mig 630t MAGMA operates with the separate wire feeders Origo™ FeedAirmatic and Origo™ Feed 304/484 M13 and Origo™ YardFeed 200 (with or without V/A meter)

Delivery includes

5 m mains cable, wheels, return cable with clamp, gas bottle platform and a guide pin for the wire feeder.

Origo™ Mig 630t MAGMA

	Origo™ Mig 630t MAGMA
Mains supply, V/Hz	230/400/415/500-50, 230/440/550/60
Fuse, slow, A	50
Mains cable, Ø mm ²	4X10
Max output at 60% duty cycle, A	630
Max output at 100% duty cycle, A	500
Setting range, A	75-630
Open circuit voltage, V	18-55
Weight, kg	254

Ordering information

Origo™ Mig 630tw MAGMA	0349 310 100
Origo™ Mig 630t MAGMA (without water cooler)	0349 310 110
Transformer for CO ₂ heater	0349 302 250
Air filter	0349 302 252
Water flow guard	0349 302 251
Cable holder	0349 303 362
Digital instrument	0455 173 882
Start booster	0349 306 125

For wire feeders, see page 26-31



Origo™ Mig C3000i/L3000i

Origo™ Mig C3000i and L3000i are the ideal systems for professional users for general applications up to 300A. The power sources are optimised to operate together with the Origo™ Feed L3004 wire feed system. The compact version has the feeder integrated in the power source. For separate versions, connection cables of up to 15 m in length provide a wide working radius and, together with all the standard accessories such as the wheel kit and lifting eye, provide full flexibility. QSet™ is an integrated function in the MA23A panel which provides a unique way of setting welding parameters in short arc. QSet™ is smart – give it a few seconds of test welding and watch how the short arc stabilizes before your very eyes. Not only does QSet™ give you a stable, short arc in no time, it also maintains optimised welding parameters.

Delivery includes

5 m mains cable with plug and return cable with clamp.

	Origo™ Mig C3000i	Origo™ Mig L3000i
Mains supply, V/Hz	3~400, 50/60	400, 3~50/60
Max output at 35% duty cycle, A	300/29 V	300/29 V
Max output at 60% duty cycle, A	240/26 V	240/26 V
Max output at 100% duty cycle, A	200/24 V	200/24 V
Wire feed, m/min	0.8-25.0	-
Wire Ø, unall. solid	0.6-1.2	-
Wire Ø, SS	0.6-1.2	-
Wire Ø, Al	1.0-1.2	-
Wire Ø, CW	0.8-1.2	-
Open circuit voltage, V	70-80	70-80
Weight, kg	38	26

Ordering information

Origo™ Mig L3000i and Origo™ Feed, L3004 MA23 Encl. incl PSF 305 3 m and connection set 1.7 m	0459 795 880
Origo™ Mig L3000i and Origo™ Feed, L3004 MA23A Encl. incl PSF 305 3 m and connection set 1.7 m Mig L3000i	0459 795 881 0459 740 880
Origo™ Mig C3000i, MA23, incl PSF 305 4.5 m	0459 750 880
Origo™ Mig C3000i, MA23A, incl PSF 305 4.5 m CoolMidi 1800	0459 750 881 0459 840 880

For wire feeders, see page 26-31. For trolleys, see page 44
For remote controls, see page 45-47
For interconnection cables, see page 33



Aristo™ Mig C3000i/L3000i

The ideal systems for professional users working with advanced applications up to 300A. Aristo™ Mig C3000i and L3000i are ideal partners when it comes to efficient production, or prefabrication, of high alloyed materials up to 5 mm thick with a very high demand on welding performance. The power sources are optimised to operate together with the Aristo™ Feed L3004 and the Aristo™ YardFeed 2000 wire feed systems. The compact version has the feeder integrated in the power source. For separate versions, connection cables of up to 15 m in length provide a wide working radius and, together with all the standard accessories such as the wheel kit and lifting eye, provide full flexibility.

Delivery includes

5 m mains cable with plug and return cable with clamp.

	Aristo™ Mig C3000i	Aristo™ Mig L3000i
Mains supply, V/Hz	400, 3~50/60	400, 3~ 50/60
Wire feed, m/min	0.8-25.0	-
Max output at 35% duty cycle, A	300/29 V	300/29 V
Max output at 60% duty cycle, A	240/26 V	240/26 V
Max output at 100% duty cycle, A	200/24 V	200/24 V
Wire Ø, unall. solid	0.6-1.2	-
Wire Ø, SS	0.6-1.2	-
Wire Ø, Al	1.0-1.2	-
Wire Ø, CW	0.8-1.2	-
Open circuit voltage, V	70-80	70-80
Weight, kg	38	26

Ordering information

Mig L3000i	0459 740 880
Aristo™ Mig C3000i, MA6 CoolMidi 1800	0459 750 882 0459 840 880

For wire feeders, see page 26-31
For trolleys, see page 44
For remote control, see page 45-47
For interconnection cables, see page 33

MIG/MAG equipment

Semi-automats



Aristo™ Mig 4500i

- Multi-process power source combining MIG/MAG, pulse MIG, MMA and carbon arc gouging.
- Reliable, smooth starts and ends supported by efficient hot-start and crater-fill functions.
- Effective man-machine communication via a number of user-friendly control panels – MA4, MA6 or Aristo™ U8.
- A wide range of predefined synergic lines. The Aristo™ U8 offers a facility for creating and storing “tailor-made” synergic lines for any material or shielding gas combination. Memory for up to 255 welding parameters.
- The TrueArcVoltage System™ measures the correct arc voltage value independent of the length of the connection cable, return cable or PSF™ welding torch.
- The Aristo™ Mig 4500i operates with the separate wire feeders Aristo™ Feed 3004/4804 MA4 and MA6, Aristo™ Feed 3004/4804 M0 (Aristo™ U8), Aristo™ RoboFeed 3004w and Aristo™ YardFeed 2000.

Delivery includes

5 m mains cable (with plug for 400V), return lead with clamp, guide pin for the wire feeder and gas bottle shelf.

Aristo™ Mig 4500i

Mains supply, V/Hz	400-415/50-60
Fuse, slow, A	20
Mains cable, Ø mm ²	4x4
Max output at 45% duty cycle, A	450
Max output at 60% duty cycle, A	425
Max output at 100% duty cycle, A	360
Current range MIG, A	15-450
Current range MMA DC, A	16-450
Open circuit voltage, V	65-80
Weight, kg	110

Ordering information

Aristo™ Mig 4500i (3x400-415 V, 50/60 Hz)	0459 349 880
Aristo™ Mig 4500iw (3x400-415 V, 50/60 Hz)	0459 349 881
Aristo™ Mig 4500i (3x230/400-415/500 V, 50 Hz; 230/440-460 V, 60 Hz)	0459 349 882
Aristo™ Mig 4500iw (3x230/400-415/500 V, 50 Hz; 230/440-460 V, 60 Hz)	0459 349 883

For wire feeders, see page 26-31



Aristo™ Mig 4000i/5000i

- Multi-process power source combining MIG/MAG, pulse MIG, MMA and carbon arc gouging.
- Reliable, smooth starts and ends, supported by efficient hot-start and crater-fill functions.
- Efficient man-machine communication by the user-friendly control panels MA4, MA6 or Aristo™ U8.
- Wide range of pre-programmed synergic lines. Aristo™ U8 provides the facility to define and store customised synergic lines for any material or gas combinations.
- Memory for 10 (MA6) or 255 (Aristo™ U8) welding parameters.
- ESAB LogicPump ELP, secures the automatic start of the water pump by connecting a water-cooled welding torch.
- TrueArcVoltage system, measures the correct arc voltage value, independent of the length of the connection cable, return cable or PSF™ welding torch.
- Dust filter to handle tough, dirty environments and avoid grinding-dust and metal particles inside the chassis.
- Operates with the separate wire feeders Aristo™ Feed 3004/4804 MA4 and MA6, Aristo™ Feed 3004/4804 M0 (Aristo™ U8), Aristo™ RoboFeed 3004w and Aristo™ YardFeed 2000.

Delivery includes

5 m mains cable incl. plug and return cable with clamp.

	Aristo™ Mig 4000i	Aristo™ Mig 5000i
Mains supply, V/Hz	3x400/50-60	3x400/50-60
Fuse, slow, A	25	35
Mains cable, Ø mm ²	4x4	4x6
Max output at 35% duty cycle, A	400	-
Max output at 60% duty cycle, A	320	500
Max output at 100% duty cycle, A	250	400
Current range MIG, A	16-400	16-500
Current range MMA DC, A	16-400	16-500
Open circuit voltage, V	55-70	72-88
Weight, kg	57	66

Ordering information

Aristo™ Mig 4000i (3x400 V, 50/60 Hz)	0458 625 880
Aristo™ Mig 4000iw (3x400 V, 50/60 Hz)	0458 625 881
Aristo™ Mig 5000i (3x400 V, 50/60 Hz)	0459 230 880
Aristo™ Mig 5000iw (3x400 V, 50/60 Hz)	0459 230 881

For wire feeders, see page 26-31. For trolleys, see page 44
For multi-voltage unit, see page 43

MIG/MAG equipment

Semi-automats



Aristo™ Mig U4000i/U5000i

- Multi-process power source combining MIG/MAG, pulse MIG, MMA, TIG, pulse TIG and carbon arc gouging.
- Reliable, smooth starts and ends, supported by efficient hot-start and crater-fill functions
- Efficient man-machine communication by the user-friendly control panel U6 or Aristo™ U8
- Wide range of pre-programmed synergic lines. Aristo™ U8 provides the facility to define and store customised synergic lines for any material or gas combinations
- Memory for 10 (U6) or 255 (Aristo™ U8) welding parameters
- ESAB LogicPump ELP, secures the automatic start of the water pump by connecting a water-cooled welding torch to the wire feeder or a water-cooled TIG torch
- TrueArcVoltage System™, measures the correct arc voltage value, independent of the length of the connection cable, return cable or PSF™ welding torch
- Dust filter to handle tough and dirty environments and avoid grinding-dust and metal particles inside the chassis
- The Aristo™ Mig U4000i/U5000i operate with the separate wire feeders Aristo™ Feed 3004/4804 U6 and M0 (Aristo™ U8)

Delivery includes

5 m mains cable incl. plug and return cable with clamp

	Aristo™ Mig U4000i	Aristo™ Mig U5000i
Mains supply, V/Hz	3x400/50-60	3x400/50-60
Fuse, slow, A	25	35
Mains cable, Ø mm ²	4x4	4x6
Max output at 35% duty cycle, A	400	-
Max output at 60% duty cycle, A	320	500
Max output at 100% duty cycle, A	250	400
Current range MIG, A	16-400	16-500
Current range MMA DC, A	16-400	16-500
Current range TIG DC, A	4-400	4-500
Open circuit voltage, V	55-90	68-88
Weight, kg	61	69



Ordering information

Aristo™ Mig U4000i (3x400 V, 50/60 Hz)	0458 625 884
Aristo™ Mig U4000iw (3x400 V, 50/60 Hz)	0458 625 885
Aristo™ Mig U5000i (3x400 V, 50/60 Hz)	0459 230 882
Aristo™ Mig U5000iw (3x400 V, 50/60 Hz)	0459 230 883
For wire feeders, see page 26-31	
For trolleys, see page 44	
For multi-voltage units, see page 43	

MIG/MAG equipment

Wire feeders



Origo™ FeedAirmatic, M10

- Suitable for Origo™ Mig 320, 410, 510, 400t, 500t and 630t.
 - The push-pull system ensures smooth, problem-free wire feed which is especially important when welding soft aluminium or other thin wires.
 - Permits welding hose packages of up to 16 m
 - Extended working radius with connection cables of up to 35 m
 - Digital V/A meters (option)
 - TrueArcVoltage System, measures the correct arc voltage value independent of the length of the connection cable, return cable or welding hose package
 - Extra versatility can be achieved by attaching a counterbalance device, wheel kit and hanging bracket.
 - Enclosed wire spool keeps the wire clean
- Allen key, hose clamp and five inlet nozzles for PKB.

Origo™ FeedAirmatic

Mains supply, V/Hz	42, 50/60
Wire feed, m/min	max 15
Max spool dimension/weight, Ø mm/kg	300 (440)/18 (30)
Wire Ø, unall. solid	0.6-1.6
Wire Ø, SS	0.6-1.6
Wire Ø, Al	0.8-1.6
Wire Ø, CW	0.8-1.6
Weight, kg	15

Ordering information

Origo™ FeedAirmatic, M10, enclosed	0459 116 680
Counter balance device compl. 300 mm bobbin	0458 705 880
Counter balance device compl. 440 mm bobbin	0458 705 882
Wheel kit	0458 707 880
Spool cover, steel	0459 431 880
Strain relief for welding torch	0457 341 881
Strain relief for interconnection cables	0459 234 880
Lifting eye	0458 706 880
Quick connector MARATHON PAC™	F102 440 880
Adapter for 5 kg spool	0455 410 001
Adapter for spool diameter 440 mm	0459 233 880
Remote control MIG 2 (only voltage adjustment)	0349 501 028
Remote control M1 (only voltage adjustment)	0459 491 895
Remote interconnection cable M1, 5m	0459 553 880
Digital V/A meter for Origo™ Mig 400t/500t	0455 173 882

For interconnection cables and assembly components, see page 32-33
For torches, see page 35-41



Origo™ Feed L302/L304

- Suitable for Origo™ Mig L305/L405
- 2/4 stroke, simplifies welding.
- Adjustable burnback timer gives correct stick-out.
- Creep start, (L304) gradual wire feed for ultimate starts.
- Spot welding (L304) for easy operation with presetting of the timer and equal lengths for the spots.
- Gas Purge and Inching (L304) no wire or gas wastage when initially setting up the equipment for welding or changing the wire spool.

Origo™ Feed L302 Origo™ Feed L304

Mains supply, V/Hz	42, 50/60	42, 50/60
Wire feed, m/min	1.5-22.0	1.5-22.0
Max spool dimension/weight, Ø mm/kg	300/18	300/18
Wire Ø, unall. solid	0.6-1.2	0.6-1.6
Wire Ø, SS	0.6-1.2	0.6-1.2
Wire Ø, Al	1.0-1.2	1.0-1.6
Wire Ø, CW	0.8-1.2	0.8-1.6
Weight, kg	12.6	13.2

Ordering information

Origo™ Feed L302, open	0459 495 782
Origo™ Feed L304, open	0459 495 882
Origo™ Feed L304w, open	0459 495 892
PSF™ 405 3 m	0458 401 882
PSF™ 405 4.5 m	0458 401 883
PSF™ 410w, 3 m	0458 400 882
PSF™ 410w, 4.5 m	0458 400 883
Bobbin cover, plastic	0458 674 880
Wheel kit	0458 707 880
Strain relief for welding torch	0457 341 881
Strain relief for connection cables	0459 234 880
Quick connector MARATHON PAC™	F102 440 880
Lifting eye	0458 706 880
Adapter for 5 kg spool	0455 410 001
Counter balance device	0458 705 880

* Connection cable 1.7 m item no. 0459 532 880 combined with Feed L304w provides a complete water-cooled solution.

For interconnection cables and assembly components, see page 32-33
For torches, see page 35-41

MIG/MAG equipment

Wire feeders



Origo™ Feed 302/304/484, M11/M12

- Suitable for Origo™ Mig 320, 410 and 510
- 2/4 stroke, simplifies welding.
- Adjustable burn-back time produces correct stick-out.
- Creep start, gradual wire feed for ultimate starts.
- Quick connectors – shortest possible set-up times.
- ESAB LogicPump ELP, automatically starts the water pump when a water-cooled welding torch is connected.
- TrueArcVoltage System™.

	Origo™ Feed 302	Origo™ Feed 304	Origo™ Feed 484
Mains supply, V/Hz	42, 50/60	42, 50/60	42, 50/60
Wire feed, m/min	1.9-20.0	1.9-25.0	1.9-25.0
Max spool dimension/weight, Ø mm/kg	300/18	300/18	300/18
Wire Ø, unall. solid	0.6-1.2	0.6-1.6	0.6-2.4
Wire Ø, SS	0.6-1.2	0.6-1.6	0.6-2.4
Wire Ø, Al	1.0-1.2	1.0-1.6	1.0-2.4
Wire Ø, CW	0.8-1.2	0.8-1.6	0.8-2.4
Weight, kg	14.3	15	19

Ordering information

Origo™ Feed 302, M11, enclosed	0459 116 781
Origo™ Feed 302w, M11, enclosed	0459 116 791
Origo™ Feed 304, M12, enclosed	0459 116 882
Origo™ Feed 304w, M12, enclosed	0459 116 892
Origo™ Feed 484, M12, enclosed	0459 116 982
Origo™ Feed 484w, M12, enclosed	0459 116 992
For interconnection cables and assembly components see page 32-33	
For torches, see page 35-41	



Origo™ Feed 304/484, M13

- Suitable for Origo™ Mig 400t, 500t and 630t MAGMA
- Additional functions to M11 and M12:
- Crater filling.
 - Digital V/A meters.

	Origo™ Feed 304	Origo™ Feed 484
Mains supply, V/Hz	42, 50/60	42, 50/60
Wire feed, m/min	1.9-25.0	1.9/25.0
Max spool dimension/weight, Ø mm/kg	300/18	300/18
Wire Ø, unall. solid	0.6-1.6	0.6-2.4
Wire Ø, SS	0.6-1.6	0.6-2.4
Wire Ø, Al	1.0-1.6	1.0-2.4
Wire Ø, CW	0.8-1.6	0.8-2.4
Weight, kg	15	19

Ordering information

Origo™ Feed 304, M13, enclosed	0459 116 883
Origo™ Feed 304w, M13, enclosed	0459 116 893
Origo™ Feed 304, M13 incl. V/A meters, enclosed	0459 116 884
Origo™ Feed 304w, M13 incl. V/A meters, enclosed	0459 116 894
Origo™ Feed 484, M13, enclosed	0459 116 983
Origo™ Feed 484w, M13, enclosed	0459 116 993
Origo™ Feed 484, M13 incl. V/A meters, enclosed	0459 116 984
Origo™ Feed 484w, M13 incl. V/A meters, enclosed	0459 116 994
For interconnection cables and assembly components, see page 32-33	
For torches, see page 35-41	

MIG/MAG equipment

Wire feeders



Origo™ Feed L3004, MA23/MA23A

- Suitable for Origo™ Mig L3000i.
- Wire feeder optimise for wire dimension up to 1.2 mm² wires.
- 2/4 stroke, simplifies welding.
- Adjustable burn-back time produces correct stick-out.
- Creep start, gradual wire feed for ultimate starts.
- Quick connectors – shortest possible set-up times.
- ESAB LogicPump ELP, automatically starts the water pump when a water-cooled welding torch is connected.
- Digital V/A meters.
- Memory, able to store three sets of welding data (wire speed and voltage).
- Digital V/A meters.
- QSet™ a built in function for stable short arc in no time.

Origo™ Feed L3004, MA23, MA23A

Mains supply, V/Hz	42, 50/60
Wire feed, m/min	0.8-25.0
Max spool dimension/weight, Ø mm/kg	300(440**) /18(30**)
Wire Ø, unall. solid	0.6-1.2
Wire Ø, SS	0.6-1.2
Wire Ø, Al	1.0-1.2
Wire Ø, CW	0.8-1.2
Weight, kg	15

Ordering information

Origo™ Feed L3004, MA23 Encl.	0459 116 587
Origo™ Feed L3004, MA23A Encl.	0459 116 588
Origo™ Feed L3004w, MA23 Encl.	0459 116 597
Origo™ Feed L3004w, MA23A Encl.	0459 116 598
Accessories:	
Wheel kit	0458 707 880
Strain relief for welding gun	0457 341 881
Strain relief for connection cables	0459 234 880
Lifting eye	0458 706 880
Quick connector MARATHON PAC™	F102 440 880
Adapter for 5 kg spool	0455 410 001
Adapter for spool 440 mm	0459 233 880**
Spool cover, steel	0459 431 880
Remote adapter kit MXH™ PP (Feed L3004)	0459 681 881
For interconnection cables and assembly componets, see page 32-33	
For torches, see page 35-41	



Aristo™ Feed L3004 MA6 and M0 (Aristo™ U8)

- Suitable for Mig L3000i.
- Wire feeder optimised for wire dimensions up to 1.2 mm² wires.
- Creep start, gas pre-flow and hot start provide a soft, more direct start with less spatter.
- Crater filling, adjustable burnback time and post-gas provides a smooth finish, extend the service life of the contact tip and guarantee no cracks at the end.
- Pre-programmed synergic lines, to ensure optimal settings with a wide choice of materials, wire dimensions and gas combinations.
- Possibility to create customer specific synergic lines (Aristo™ U8)
- Memory for 10 sets of parameters (MA6) or 255 set of parameters (Aristo™ U8).
- Quick connectors – shortest possible set-up times.
- ESAB LogicPump ELP ensures the automatic start of the water pump when connecting a water-cooled welding torch.
- TrueArcVoltage system for measuring the correct arc voltage value, regardless of the length of the connection cable, return cable or PSF™ welding torch.
- Short pulse welding.

Aristo™ Feed L3004 MA6

Mains supply, V/Hz	42/50-60
Wire feed, m/min	0.8-25
Max spool dimension/weight, Ø mm/kg	300/18
Wire Ø, GMAW unalloyed	0.6-1.2
Wire Ø, GMAW SS	0.6-1.2
Wire Ø, GMAW Al	1.0-1.2
Wire Ø, FCAW	0.9-1.2
Weight, kg	15

Ordering information

Aristo™ Feed L3004 MA6, encl.	0458 806 586
Aristo™ Feed L3004w MA6, encl.	0458 806 596
Aristo™ Feed L3004 M0, encl.	0458 806 581
Aristo™ U8	0456 290 981
Wheel kit	0584 707 880
Strain relief for welding torch	0457 341 881
Strain relief for connections cables	0459 234 880
For interconnection cables and assembly components, see page 32–33	
For torches, see page 35-41. For remote controls, see page 45-47	

MIG/MAG equipment

Wire feeders



Aristo™ Feed 3004/4804, MA4/MA6

- Suitable for Aristo™ Mig U4000i/U5000i (U6)
- Suitable for Aristo™ Mig 4000i/5000i/4500i (U8)
- 2/4 stroke, simplifies handling of the welding torch.
- Creep start, gas pre-flow and hot start provide a soft, more direct start with less spatter.
- Crater filling, adjustable burn-back time and post-gas provides a smooth finish, extend the service life of the contact tip and guarantee no cracks at the end.
- Pre-programmed synergic lines, to ensure optimal settings with a wide choice of materials, wire dimensions and gas combinations (MA6).
- Memory for 10 parameter set (MA6).
- Quick connectors – shortest possible set-up times.
- ESAB LogicPump ELP, secures the automatic start of the water pump by connecting a water-cooled welding torch.
- TrueArcVoltage system, measures the correct arc voltage value, independent of the length of the connection cable, return cable or PSF™ welding torch.

Aristo™ Feed 3004 **Aristo™ Feed 4804**

	Aristo™ Feed 3004	Aristo™ Feed 4804
Mains supply, V/Hz	42/50-60	42/50-60
Wire feed, m/min	0.8-25.0	0.8-25.0
Max spool dimension/weight, Ø mm/kg	300/18	300/18
Wire Ø, unall. solid	0.6-1.6	0.6-2.4
Wire Ø, SS	0.6-1.6	0.6-2.4
Wire Ø, Al	1.0-1.6	1.0-2.4
Wire Ø, CW	0.8-1.6	0.8-2.4
Weight, kg	17.5	22.5

Ordering information

Aristo™ Feed 3004, MA4, enclosed	0458 806 884
Aristo™ Feed 3004w, MA4, enclosed	0458 806 894
Aristo™ Feed 3004, MA6, enclosed	0458 806 886
Aristo™ Feed 3004w, MA6, enclosed	0458 806 896
Aristo™ Feed 4804, MA4, enclosed	0458 806 984
Aristo™ Feed 4804w, MA4, enclosed	0458 806 994
Aristo™ Feed 4804, MA6, enclosed	0458 806 986
Aristo™ Feed 4804w, MA6, enclosed	0458 806 996
For interconnection cables and assembly components, see page 32-33	
For torches, see page 35-41. For remote controls, see page 45-47	

Aristo™ Feed 3004/4804, U6/M0

- Suitable for Aristo™ Mig U4000i/U5000i (U6) and 4000i/5000i/U4000i/U5000i/4500i (U8)
- 2/4 stroke, simplifies handling of the welding torch.
- Creep start, gas pre-flow and hot start provide a soft, more direct start with less spatter.
- Crater filling, adjustable burn-back time and post gas provides a smooth finish, extend the service life of the contact tip and guarantee no cracks at the end.
- Pre-programmed synergic lines, to ensure optimal settings with a wide choice of materials, wire dimensions and gas combinations.
- Possibility to create synergic lines (Aristo™ U8).
- Memory for 10 or 255 parameter sets.
- Quick connectors – shortest possible set-up times.
- ESAB LogicPump ELP, secures the automatic start of the water pump by connecting a water-cooled welding torch.
- TrueArcVoltage System™, measures the correct arc voltage value, independent of the length of the connection cable, return cable or PSF™ welding torch.

Aristo™ Feed 3004 **Aristo™ Feed 4804**

	Aristo™ Feed 3004	Aristo™ Feed 4804
Mains supply, V/Hz	42/50-60	42/50-60
Wire feed, m/min	0.8-25.0	0.8-25.0
Max spool dimension/weight, Ø mm/kg	300/18	300/18
Wire Ø, unall. solid	0.6-1.6	0.6-2.4
Wire Ø, SS	0.6-1.6	0.6-2.4
Wire Ø, Al	1.0-1.6	1.0-2.4
Wire Ø, CW	0.8-1.6	0.8-2.4
Weight, kg	17.5	22.5

Ordering information

Aristo™ Feed 3004, M0, enclosed	0458 806 881
Aristo™ Feed 3004w, M0, enclosed	0458 806 891
Aristo™ Feed 3004, U6, enclosed	0458 806 887
Aristo™ Feed 3004w, U6, enclosed	0458 806 897
Aristo™ Feed 4804, M0, enclosed	0458 806 981
Aristo™ Feed 4804w, M0, enclosed	0458 806 991
Aristo™ Feed 4804, U6, enclosed	0458 806 987
Aristo™ Feed 4804w, U6, enclosed	0458 806 997
For interconnection cables and assembly components, see page 32-33	
For torches, see page 35-41	
For remote controls, see page 45-47	

MIG/MAG equipment

Wire feeders



Aristo™ RoboFeed 3004w

Aristo™ RoboFeed 3004w is a complete feeding unit that includes a drive control system and the operational functions gas purge and wire inching forward and reverse. The unit is equipped with mounting bolts with rubber absorbers to protect components in the event of high acceleration and retardation power from the robot. Suitable for Aristo™ Mig 4500i/4000i/5000i.

Aristo™ RoboFeed 3004w

Mains supply, V/Hz	42, 50/60
Wire feed, m/min	0.8-25.0
Wire Ø, unall. solid	0.6-1.6
Wire Ø, SS	0.6-1.6
Wire Ø, Al	1.0-1.6
Wire Ø, CW	0.8-1.6
Weight, kg	7.3

Ordering information

Aristo™ RoboFeed 3004w 23p Burndy	0461 000 880
Aristo™ RoboFeed 3004w 12p Burndy	0461 000 881
Interconnection cable 5.0 m air-cooled	0740 538 890
Interconnection cable 10.0 m air-cooled	0740 538 881
Interconnection cable 15.0 m air-cooled	0740 538 882
Interconnection cable 25.0 m air-cooled	0740 538 883
Interconnection cable 35.0 m air-cooled	0740 538 884
Interconnection cable 5.0 m water-cooled	0740 538 895
Interconnection cable 10.0 m water-cooled	0740 538 886
Interconnection cable 15.0 m water-cooled	0740 538 887
Interconnection cable 25.0 m water-cooled	0740 538 888
Interconnection cable 35.0 m water-cooled	0740 538 889
Side panel with window	On request
Assembly bracket universal	0461 038 880
Quick connector MARATHON PAC™	F102 440 880
Wire conduit 1.8 m	F102 437 881
Wire conduit 3.0 m	F102 437 882
Wire conduit 4.5 m	F102 437 883
Wire conduit 8.0 m	F102 437 884
Wire conduit 12.0 m	F102 437 885



Origo™ YardFeed 200, M13y

- Suitable for Origo™ Mig 320/410/510/630t (without V/A meter), 400t/500t (with V/A meter).
- 2/4 stroke, simplifies handling of the welding torch.
- Safety switch with optional heating element.
- Gas purge and wire inching.
- Manual gas flow valve inside the cabinet.
- Gas flow manometer incl. manual valve (option).
- High strength steel to make the feeder light and robust especially resistant against rough handling.
- Integrated handle in a protective frame simplifies the handling through man-holes and other difficult-to-access areas.
- Equipped with military standard control cable connector.
- Adjustable burn-back timer provides a smooth finish, extends the lifetime of the contact tip and guarantee no cracks at the end.
- Quick connectors- shortest possible set-up times.
- ESAB LogicPump ELP, secures automatic start of water pump by connection of a water cooled welding torch.
- TrueArcVoltage System™, measures the correct arc voltage value independent of the length of the connection cable, return cable or welding torch.

Origo™ YardFeed 200

Mains supply, V/Hz	42, 50/60
Wire feed, m/min	1.9-25.0
Max spool dimension/weight, Ø mm/kg	200/5
Wire Ø, unall. solid	0.6-1.2
Wire Ø, SS	0.6-1.2
Wire Ø, Al	1.0-1.2
Wire Ø, CW	0.8-1.4
Weight, kg	11.3

Ordering information

Origo™ YardFeed 200	0459 906 881
Origo™ YardFeed 200w	0459 906 891
Origo™ YardFeed 200 incl.V/A meter	0459 906 882
Origo™ YardFeed 200w incl.V/A meter	0459 906 892
Strain relief for welding torch	0457 341 881
Gas flow manometer kit	0460 005 880
Heating element kit	0459 041 880
MMC protection	0459 961 880
For interconnection cables and assembly components, see page 32-33	

MIG/MAG equipment

Wire feeders



Aristo™ YardFeed 2000, MA6

- Suitable with Aristo™ Mig 4000i//5000i/U4000i and U5000i and Aristo™ Mig L3000i
- 2/4 stroke, simplifies handling of the welding torch.
- Safety switch with optional heating element
- Gas purge and wire inching
- Manual gas flow valve inside the cabinet
- Gas flow manometer incl. manual valve (option)
- Equipped with military standard control cable connector
- Creep start, gas pre-flow and hot start provide a soft and more direct start with less spatter.
- Crater filling, adjustable burn-back time and post gas provides a smooth finish, extend the lifetime of the contact tip and guarantees no cracks at the end.
- Pre-programmed synergic lines, to ensure optimum settings with a wide choice of materials, wire dimensions and gas combinations.
- Memory for 10 parameter sets
- High strength steel, integrated handle, quick connectors, ESAB LogicPump ELP, TrueArcVoltage System, as for Origo™ YardFeed 200.

Aristo™ YardFeed 2000

Mains supply, V/Hz	42, 50/60
Wire feed, m/min	0.8-25.0
Max spool dimension/weight, Ø mm/kg	200/5
Wire Ø, unall. solid	0.6-1.2
Wire Ø, SS	0.6-1.2
Wire Ø, Al	1.0-1.2
Wire Ø, CW	0.8-1.4
Weight, kg	11.3

Ordering information

Aristo™ YardFeed 2000	0459 906 886
Aristo™ YardFeed 2000w	0459 906 896
Strain relief for welding torch	0457 341 881
Gas flow manometer kit	0460 005 880
Heating element kit	0459 941 880
Remote interconnection cable 5 m	0459 960 880
MMC protection	0459 961 880
OKC angel connection for MMA	0365 557 001
For interconnection cables and assembly components, see page 32-33	
For remote controls, see page 45-47	



FeedSelector

FeedSelector is a switch unit for connecting two wire feeders to one welding rectifier. Can be used when welding with two different electrode wires and one or two shielding gases is required. The FeedSelector switches the welding current and the required control circuits between the wire feeders. FeedSelector is an excellent partner for Origo™ Mig 400t/400w/500t/500w/630w/410/410w/510/510w machines.

Delivery includes

FeedSelector, assembly elements, instruction manual.

FeedSelector

Mains supply, V/Hz	42, 50/60
Max output at 35% duty cycle, A	630
Max output at 60% duty cycle, A	500
Max output at 100% duty cycle, A	400
Weight, kg	34

Ordering information

FeedSelector	0349 308 248
--------------	--------------

MIG/MAG equipment

Assembly possibilities for wire feeders



Counterbalance device/mast

The feeder unit is assembled with a spring unit which lifts the welding torch and hose with adjustable force. The lifting force is independent of the weight of the wire spool. The device can be rotated through 360°.

Ordering information

Counterbalance device for Aristo™ Feed and Origo™ Feed

0458 705 880



Turning piece

The feeder unit can be rotated on the power source through 360°.

Ordering information

Turning piece for Aristo™ Feed and Origo™ Feed MPac versions

0458 703 880



Wheel kit

Increases the working radius from the power source. The wheel kit has four wheels and can also be placed to pivot on the power source.

Ordering information

Wheel kit for Aristo™ Feed and Origo™ Feed

0458 707 880



Lifting eye

Using this device, the feeder unit can be suspended in a swinging arm.

Ordering information

Lifting eye for Aristo™ Feed and Origo™ Feed

0458 706 880



Strain relief for welding torch

Recommended in combination with wheel kit.

Ordering information

Strain relief for Aristo™ Feed/ Origo™ Feed and Aristo™ YardFeed 2000/Origo™ YardFeed 200

0457 341 881

MIG/MAG equipment

Assembly possibilities for wire feeders



Interconnection cables

Ordering information

Aristo™ Mig – Aristo™ Feed Aristo™/Origo™ Mig L3000i – Aristo™/Origo™ Feed L3004

Length (m)	Air cooled 50 mm ²	Water-cooled 50 mm ²	Air cooled 95 mm ²	Water-cooled 95 mm ²	Type of connector
1.7 m	0456 528 580	0456 528 590	0456 528 880	0456 528 885	Burndy 12
5 m	0456 528 581	0456 528 591	0456 528 890	0456 528 895	Burndy 12
10 m	0456 528 582	0456 528 592	0456 528 881	0456 528 886	Burndy 12
15 m	0456 528 583	0456 528 593	0456 528 882	0456 528 887	Burndy 12
25 m			0456 528 883	0456 528 888	Burndy 12
35 m			0456 528 884	0456 528 889	Burndy 12

Origo™ Mig – Origo™ Feed

Length (m)	Air cooled 50 mm ²	Air cooled 70 mm ²	Water-cooled 70 mm ²	Air cooled 95 mm ²	Water-cooled 95 mm ²	Type of connector
1.7 m		0469 836 880	0469 836 885	0469 836 890	0469 836 895	Burndy 23
5 m	0469 836 980	0469 836 981	0469 836 983	0468 836 982	0469 836 984	Burndy 23
10 m		0469 836 881	0469 836 886	0469 836 891	0469 836 896	Burndy 23
15 m		0469 836 882	0469 836 887	0469 836 892	0469 836 897	Burndy 23
25 m		0469 836 883	0469 836 888	0469 836 893	0469 836 898	Burndy 23
35 m		0469 836 884	0469 836 889	0469 836 894	0469 836 899	Burndy 23

Origo™ Mig – Origo™ FeedAirmatic

Length (m)	Air cooled 70 mm ²	Type of connector
1.7 m	0469 836 900	Burndy 23
5 m	0469 836 901	Burndy 23
10 m	0469 836 902	Burndy 23
15 m	0469 836 903	Burndy 23

Aristo™ Mig – Mig L3000i – Aristo™ YardFeed 2000

Length (m)	Air cooled 50 mm ²	Water-cooled 50 mm ²	Type of connector
10 m	0459 528 582	0459 528 592	Burndy 12 - Amphenol 10
15 m	0459 528 583	0459 528 593	Burndy 12 - Amphenol 10
25 m	0459 528 584	0459 528 594	Burndy 12 - Amphenol 10
35 m	0459 528 585	0459 528 595	Burndy 12 - Amphenol 10
50 m	0459 528 586	0459 528 596	Burndy 12 - Amphenol 10

Origo™ Mig – Origo™ YardFeed 200

Length (m)	Air cooled 50 mm ²	Water-cooled 50 mm ²	Type of connector
10 m	0459 836 582	0459 836 592	Burndy 23 - Amphenol 19
15 m	0459 836 583	0459 836 593	Burndy 23 - Amphenol 19
25 m	0459 836 584	0459 836 594	Burndy 23 - Amphenol 19
35 m	0459 836 585	0459 836 595	Burndy 23 - Amphenol 19
50 m	0459 836 586	0459 836 596	Burndy 23 - Amphenol 19

Origo™ Mig L305/L405/L405w – Origo™ Feed L302/L304/L304w

Length (m)	Air cooled 50 mm ²	Water-cooled 50 mm ²	Type of connector
1.7 m	0459 532 880	0459 532 880*	Mate n lok 15
5 m	0459 532 881	0459 532 891	Mate n lok 15
10 m	0459 532 882	0459 532 892	Mate n lok 15

* Suits Origo™ Feed L304w

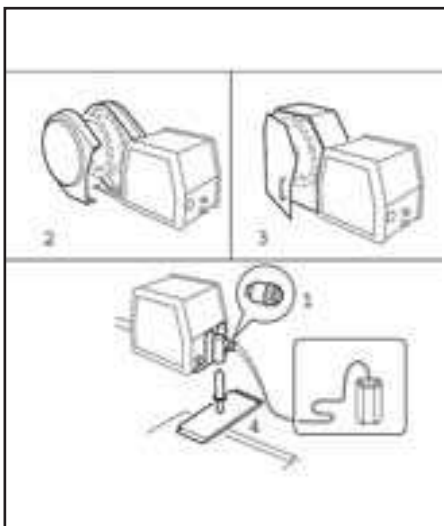

Other equipment for MIG/MAG welding

Ordering information

1. Quick connector for MARATHON PAC™	F102 440 880
2. Spool cover plastic Aristo™ Feed/Origo™ Feed	0458 674 880
3. Spool cover steel Aristo™ Feed/Origo™ Feed	0459 431 880
4. Guide pin for Aristo™ Mig	0458 731 880

MIG/MAG equipment

Wear parts for wire feeders

Origo™ Feed L302

Wire Ø mm	Wire type	Feed roller	Pressure roller	Inlet nozzle	Insert tube	Outlet nozzle	Groove type
0.6 / 0.8	Fe, Ss, C	0367 556 001	0455 907 001	0466 074 001	0455 889 001	0455 886 001	V
0.8 / 1.0	Fe, Ss, C	0367 556 002	0455 907 001	0466 074 001	0455 889 001	0455 886 001	V
1.0 / 1.2	Fe, Ss, C	0367 556 003	0455 907 001	0466 074 001	0455 889 001	0455 886 001	V
1.0 / 1.2	Al	0367 556 004	0455 907 001	0466 074 001	0455 894 001	0455 885 001	U

C=cored wire

Bold = standard deliveries

Origo™ Feed L304

Wire Ø mm	Wire type	Feed roller	Pressure roller	Inlet nozzle	Intermediate nozzle	Outlet nozzle	Groove type
0.6 / 0.8	Fe, Ss, C	0369 557 001	0455 907 001	0455 049 001	0455 072 002	0469 837 880	V
0.8 / 1.0	Fe, Ss, C	0369 557 002	0455 907 001	0455 049 001	0455 072 002	0469 837 880	V
1.0 / 1.2	Fe, Ss, C	0369 557 003	0455 907 001	0455 049 001	0455 072 002	0469 837 880	V
1.4 / 1.6	Fe, C	0369 557 013	0455 907 001	0455 049 001	0455 072 002	0469 837 880	V
0.8 / 0.9	Al	0369 557 011	0455 907 001	0455 049 001	0456 615 001	0469 837 881	U
1.0 / 1.2	Al	0369 557 006	0455 907 001	0455 049 001	0456 615 001	0469 837 881	U

C=cored wire

Bold = standard deliveries

Aristo™ Feed 3004 and Origo™ Feed 304, Aristo™ Feed L3004 and Origo™ Feed L3004, Aristo™ YardFeed 2000 and Origo™ YardFeed 200

Wire Ø mm	Wire type	Feed roller	Inlet nozzle	Intermediate nozzle	Outlet nozzle	Groove type	! Marking
0.6 / 0.8	Fe, Ss, C	0459 052 001	0455 049 001	0455 072 002	0469 837 880	V	0.6 S2 & 0.8 S2
0.8 / 0.9-1.0	Fe, Ss, C	0459 052 002	0455 049 001	0455 072 002	0469 837 880	V	0.8 S2 & 1.0 S2*
0.9-1.0 / 1.2	Fe, Ss, C	0459 052 003	0455 049 001	0455 072 002	0469 837 880	V	1.0 S2 & 1.2 S2
1.4 / 1.6	Fe, Ss, C	0459 052 013	0459 049 001	0455 072 002	0469 837 880	V	1.4 S2 & 1.6 S2
0.9-1.0 / 1.2	C	0458 825 001	0455 049 001	0455 072 002	0469 837 880	V-K	1.0 R2 & 1.2 R2
1.2 / 1.4	C	0458 825 002	0455 049 001	0455 072 002	0469 837 880	V-K	1.2 R2 & 1.4 R2
1.6	C	0458 825 003	0459 049 001	0455 072 002	0469 837 880	V-K	1.6 R2
0.8 / 0.9-1.0	Al	0458 824 001	0455 049 001	0456 615 001	0469 837 881	U	0.8 A2 & 1.0 A2
1.2 / 1.6	Al	0458 824 003	0455 049 001	0456 615 001	0469 837 881	U	1.2 A2 & 1.6 A2

C=cored wire

K=knurled groove

Bold = standard deliveries

* L3004/C3000i

Aristo™ Feed 4804 and Origo™ Feed 484

Wire Ø mm	Wire type	Feed roller	Bogie	Outlet nozzle	Intermediate nozzle	Groove type	= Marking	1	2	3
0.6-1.2	Fe,Ss,C	0366 966 880	0366 902 880	0469 837 880	0156 603 001	V	1	0.6-0.8	0.9-1.0	1.2
0.9-1.6	Fe,Ss,C	0366 966 900	0366 902 900	0469 837 880	0156 603 001	V	6	0.9-1.0	1.2	1.4-1.6
1.2	Fe,Ss,C	0366 966 889	0366 902 894	0469 837 880	0156 603 001	V	7	1.2	1.2	1.2
1.4-1.6	Fe,Ss,C	0366 966 881	0366 902 881	0469 837 880	0156 603 001	V	2	1.4-1.6	2.0	2.4
2.0-2.4	Fe,Ss,C	0366 966 881	0366 902 881	0469 837 882	0156 603 002	V	2	1.4-1.6	2.0	2.4
1.2-1.6	C	0366 966 882	0366 902 882	0469 837 880	0332 322 001	V-K	3	1.2	1.4-1.6	2.0
2.0	C	0366 966 882	0366 902 882	0469 837 882	0332 322 001	V-K	3	1.2	1.4-1.6	2.0
2.4	C	0366 966 883	0366 902 883	0469 837 882	0333 322 002	V-K	4	2.4	not used	not used
1.0-1.6	Al	0366 966 899	0366 902 899	0469 837 881	0156 603 001	U	U4	1.0	1.2	1.6
1.2	Al	0366 966 885	0366 902 886	0469 837 881	0156 603 001	U	U2	1.2	1.2	1.2

C=cored wire

K=knurled groove

Bold = standard deliveries

Origo™ Feed 302

Wire Ø mm	Wire type	Feed roller	Pressure roller	Inlet nozzle	Insert tube	Outlet nozzle	Groove type
0.6 / 0.8	Fe, Ss, C	0369 557 001	0369 728 001	0466 074 001	0455 889 001	0455 886 001	V
0.8 / 1.0	Fe, Ss, C	0369 557 002	0369 728 001	0466 074 001	0455 889 001	0455 886 001	V
1.0 / 1.2	Fe, Ss, C	0369 557 003	0369 728 001	0466 074 001	0455 889 001	0455 886 001	V
1.0-1.2 / 1.4-1.6	C	0369 557 004	0466 262 001	0466 074 001	0455 889 001	0455 886 001	V-K
0.8 / 0.9	Al	0369 557 011	0369 728 001	0466 074 001	0455 894 001	0455 885 001	U
1.0 / 1.2	Al	0369 557 006	0369 728 001	0466 074 001	0455 894 001	0455 885 001	U

C=cored wire

K=knurled groove

Bold = standard deliveries

MIG/MAG equipment

Torches and components



PSF™ water-cooled

The water-cooled PSF™ torches are probably the coolest welding torches on the market. The excellent cooling allows for a smaller swan neck with no reduction in current capacity, plus reduced wear part consumption. The ergonomic handle is equipped with an integrated hanger that is folded away for increased accessibility. A swivel at the back of the handle reduces strain on the welder's wrist. Together with the opportunity to use different angled swan necks, this provides easy access to all welding positions and a comfortable working position.

Both torches are available with a built-in, three-step, remote-control switch.

	PSF™ 410w/ 410w RS3	PSF™ 510w/ 510w RS3
--	------------------------	------------------------

Wire Ø, unall. solid	0.8-1.6	1.0-2.4
Wire Ø, SS	0.8-1.6	1.0-1.6
Wire Ø, Al	1.0-1.6	1.2-2.4
Wire Ø, CW	0.9-1.6	0.9-2.0

Ordering information

PSF™ 410w, 3 m/4.5 m	0458 400 882/883
PSF™ 510w, 3 m/4.5 m	0458 400 884/885
PSF™ 410w RS3, 3 m/4.5 m	0458 400 898/899
PSF™ 510w RS3, 3 m/4.5 m	0458 400 900/901

w = water connection
RS3 = remote control 3-steps



PSF™ self-cooled

There are four different sizes of self-cooled PSF™ welding torches and they can be ordered with two different hose lengths. The handles are ergonomically curved. A range of different angled swan necks provides easy access to all the different welding positions and a comfortable working position.

PSF™ 405 is available with a built-in, three-step, remote-control switch.

	PSF™ 250	PSF™ 305	PSF™ 405/ 405 RS3	PSF™ 505
--	-------------	-------------	----------------------	-------------

Max load at 60% duty cycle, A	250	315	380	475
Wire Ø, unall. solid	0.6-1.0	0.8-1.2	0.8-1.6	1.0-2.4
Wire Ø, SS	0.6-1.0	0.8-1.2	0.8-1.2	1.0-1.6
Wire Ø, Al	1.0	1.0-1.2	1.0-1.6	1.0-2.4
Wire Ø, CW	1.0	1.0-1.2	1.0-1.6	1.2-2.0

Ordering information

PSF™ 250, 3 m/4.5 m	0368 100 882/883
PSF™ 305, 3 m/4.5 m	0458 401 880/881
PSF™ 405, 3 m/4.5 m	0458 401 882/883
PSF™ 505, 3 m/4.5 m	0458 401 884/885
PSF™ 405 RS3, 4.5 m	0458 401 893

RS3 = remote control 3-steps

MIG/MAG equipment

Torches and components

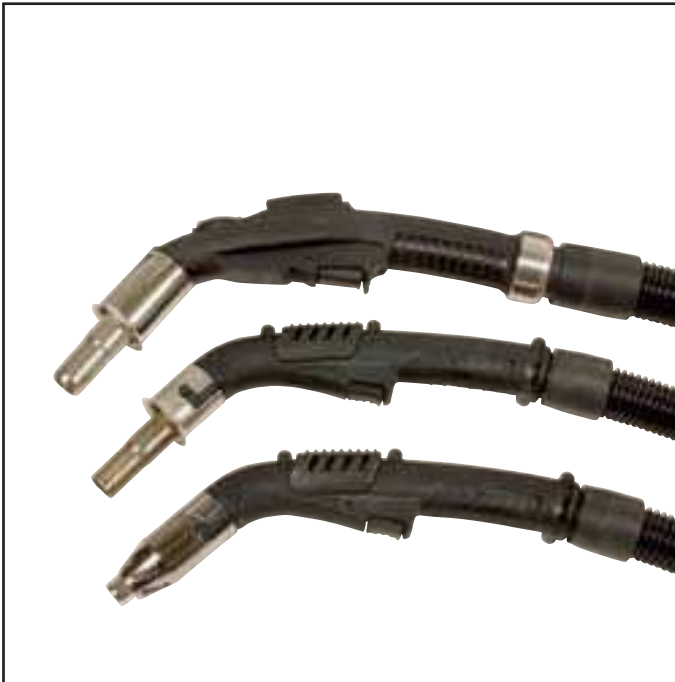

PSF™ Centrovac self-cooled

The Centrovac welding torches have integrated smoke extraction, providing a smoke-free working environment for the welder. The handles are ergonomically designed and incorporate a reduction valve for suction adjustment. The PSF™ 250C and 315CLD have a small handle, providing easy access to all the different welding positions. PSF™ 405C has a swivel at the back of the handle to reduce the strain on the welder's wrist.

	PSF™ 250C	PSF™ 315CLD	PSF™ 405C
Max load at 60% duty cycle, A	250	315	380
Wire Ø, unall. solid	0.6-1.2	0.8-1.2	0.8-1.6
Wire Ø, SS	0.6-1.2	0.8-1.2	0.8-1.6
Wire Ø, Al	0.8-1.2	1.0-1.2	1.0-1.6
Wire Ø, CW	0.9	0.9-1.2	0.9-1.6

Ordering information

PSF™ 250 C, 3 m/4.5 m	0468 410 882/883
PSF™ 315 CLD, 3 m/4.5 m	0468 410 885/886
PSF™ 405C, 3 m/4.5 m	0458 499 882/883
C = smoke extraction	



PSF™ Centrovac water-cooled

The water-cooled Centrovac welding torch is probably the coolest welding torch on the market. The integrated smoke extraction provides a smoke-free working environment for the welder. Ergonomically-designed handle incorporating a reduction valve for suction adjustment. The water-cooled Centrovac torch have a swivel at the back of the handle to reduce the strain on the welder's wrist. PSF™ 410Cw RS3 are available with a built-in, three-step, remote-control switch.

	PSF™ 410Cw/ 410Cw RS3
Wire Ø, unall. solid	0.8-1.6
Wire Ø, SS	0.8-1.2
Wire Ø, Al	1.0-1.6
Wire Ø, CW	0.9-1.6

Ordering information

PSF™ 410Cw, 3 m/4.5 m	0458 450 880/881
PSF™ 410Cw RS3, 3 m/4.5 m	0458 450 884/885
C = smoke extraction	
w = water connection	
RS3 = remote control 3-steps	

MIG/MAG equipment

Torches and components



PSF™ 315M

Welding torch for MIG/MAG welding in mechanised applications.

- Precision bent swan neck – easy to change torch without recalibrating.
- Liners with controlled flexibility in both steel and PTFE – for stable wire feeding.
- Connection for pneumatic spatter cleaning.
- Contact tip protrudes 3 mm to increase accessibility.
- Spatter protection – high temperature resistance and prevents welding spatter from penetrating the swan neck.



PSF™ 315M

Max output at 60% duty cycle, A	315 (CO ₂)
Max output at 60% duty cycle, A	285 (MIX)
Max output at 100% duty cycle, A	200 (CO ₂)
Max output at 100% duty cycle, A	170 (MIX)
Wire Ø, unall. solid	0.8-1.2
Wire Ø, SS	0.8-1.2
Wire Ø, Al	1.0-1.2
Wire Ø, CW	0.9-1.2

Ordering information

PSF™ 315M 1.5 m standard 25 euro	0367 233 894
PSF™ 315M 1.5 m straight euro	0367 233 896
PSF™ 315M 2.2 m standard 25 euro	0367 233 900
PSF™ 315M 2.2 m straight euro	0367 233 901
PSF™ 315M 3.0 m standard 25 euro	0367 233 898
PSF™ 315M 3.0 m straight euro	0367 233 905
PSF™ 315M 1.5 m 25 Ext 100 euro	0367 233 904

MIG/MAG equipment

Torches and components



PKB™ 250/400

The pneumatic A9A is a push-pull system consisting of PKB™ 250 and 400, Origo™ FeedAirmatic wire feeder and welding hoses of different lengths and dimensions. The torch is powered by air and the feed speed is set steplessly by a knob on the torch. The trigger permits creep starts and speed reductions during welding. The hose connection supplies current, wire, shielding gas and air in the same connection.

	PKB™ 250	PKB™ 400
Pressure, bar	5	5
Wire Ø, unall. solid	0.6-1.2	0.6-1.6
Wire Ø, SS	0.6-1.2	0.6-1.6
Wire Ø, Al	0.8-1.2	0.8-1.6
Wire Ø, CW	1.0-1.2	1.0-1.6
Wire feed, m/min	0-18	0-18
Weight, kg	1.2	1.4

Ordering information

PKB™ 250 welding torch	0152 700 881
5 m hose for PKB™ 250	0468 790 880
10 m hose for PKB™ 250	0468 790 881
16 m hose for PKB™ 250	0468 790 882
PKB™ 400 welding torch	0152 470 881
5 m hose for PKB™ 400	0468 790 883
10 m hose for PKB™ 400	0468 790 884
16 m hose for PKB™ 400	0468 790 885



MXL™ Torches

- 4 gas-cooled welding torches.
- Ergonomic handles.
- Optimum cooling of torches, extended service life for swan necks and wearing parts.
- Spring-loaded contact pins in the central connector.
- Hose length 3 and 4 m.
- Gas nozzles in 3 different versions, standard, straight and conical, provide maximum flexibility and an optimum service life.

	MXL™ 150v	MXL™ 200	MXL™ 270	MXL™ 340
Wire Ø, unall. solid	0.6-0.8	0.6-1.0	0.8-1.2	0.8-1.2
Wire Ø, SS	0.6-0.8	0.6-1.0	0.8-1.2	0.8-1.2
Wire Ø, Al	-	1.0	1.0-1.2	1.0-1.2
Wire Ø, CW	0.8	0.8-0.9	0.9-1.2	0.9-1.2
Weight, kg (3.0/4.0 m)	1.1 (2.5 m)	1.6/2.0	2.2/2.6	2.6/3.7

Ordering information

MXL™ 150v, hose length 2.5 m	0700 200 001
MXL™ 200, hose length 3.0 m	0700 200 002
MXL™ 200, hose length 4.0 m	0700 200 003
MXL™ 270, hose length 3.0 m	0700 200 004
MXL™ 270, hose length 4.0 m	0700 200 005
MXL™ 340, hose length 3.0 m	0700 200 006
MXL™ 340, hose length 4.0 m	0700 200 007

MIG/MAG equipment

Torches and components



MXH™ 300/400w PP

MXH™ 300/400w PP are electric push-pull welding torches.

- Air- and water-cooled pistol grip torches with straight and curved 45 degree swan necks.
- Allows 360 degree rotation of the curved swan neck to suit various welding positions
- Couples with ESAB feeding mechanisms to produce a high performance push-pull feeding system.
- Ideal for feeding aluminium and other small diameter wires long distances.
- Wire feed speed controlled by potentiometer located in the torch handle.



	MXH™ 300 PP	MXH™ 400w PP
--	----------------	-----------------

Wire Ø, unall. solid	0.8-1.2	0.8-1.2
Wire Ø, SS	0.8-1.2	0.8-1.2
Wire Ø, Al	0.8-1.2	0.8-1.6
Wire Ø, CW	0.9-1.2	0.9-1.2
Weight, kg: 6 m / 10 m	6.6/9.2	5.6/7.8

Ordering information

MXH™ 300 PP 6.0 m	0700 200 017
MXH™ 300 PP 10.0 m	0700 200 018
MXH™ 400 w PP 6.0 m	0700 200 015
MXH™ 400 w PP 10.0 m	0700 200 016
MXH™ 400w PP 45° 10.0 m	0700 200 019
Swan neck 45 water cooled	0700 200 251
Swan neck 45 air cooled	0700 200 253
Connection kit Aristo™ Feed, Origo™ Feed L3004	0459 020 883
Connection and wire feed control kit Aristo™ Feed, Origo™ Feed L3004	0459 681 881
Connection and wire feed control kit Mig C3000i	0459 681 891
Connection kit Origo™ Mig C340 PRO	0349 308 980
Connection kit Origo™ Mig C420 PRO	0349 308 337

MIG/MAG equipment

Torches and components

Type of welding torch		PSF™ 250 PSF™ 250C	PSF™ 315 CLD	PSF™ 305 PSF™ 410w PSF™ 410Cw	PSF™ 405 PSF™ 510w PSF™ 405C	PSF™ 505	
Wear parts							
Swan neck self-cooled PSF™ 250-505	Acc. 0°	0469 329 880	-	0469 333 880	0469 334 880	0469 335 880	
	Std. 45°	0366 315 880	-	0366 388 880	0366 389 880	0366 390 880	
	Acc. 60°	0467 985 880	-	0467 988 881	0467 988 880	0467 989 880	
Swan neck water-cooled PSF™ 410w-510w	Acc. 0°	-	-	0458 403 886	0458 403 887	-	
	Std. 45°	-	-	0458 403 881	0458 403 882	-	
	Acc. 60°	-	-	0458 403 884	0458 403 885	-	
Swan neck self-cooled Centrovac	Std. 45°	0366 315 880	0457 862 880	-	0459 763 880	-	
Swan neck water-cooled Centrovac	Std. 45°	-	-	0458 487 880	-	-	
Gas nozzle self-/water-cooled Threaded	Tapered	0458 465 881	0458 465 882	0458 465 882	0458 465 883	0458 465 884	
	Std.	0458 464 881	0458 464 882	0458 464 882	0458 464 883	0458 464 884	
	Straight	0458 470 881	0448 470 882	0458 470 882	0458 470 883	0458 470 884	
Spatter protection	self-/water-cooled gas nozzle	0458 471 002	0458 471 003	0458 471 003	0458 471 004	0458 471 005	
Spotwelding acc.	self- and water-cooled	0366 643 881	0366 643 882	0366 643 882	0366 643 883	0366 643 884	
Tip adaptor self-cooled	M6	0366 314 001	-	0366 394 001 (305)	0366 394 001	-	
	M8	-	0366 394 001	0366 394 002 (410w)	0366 394 002	0366 395 001	
	HELIX™ M7	0368 310 001	0368 311 001	0368 311 001	0368 311 001	0368 312 001	
	HELIX™ M8	-	-	0366 394 002	0366 394 002	0366 395 001	
Contact tip		M6 x 27 CuCrZr					
CO₂	Mix/Ar	0.6	0468 500 001	0468 500 001	0468 500 001	0468 500 001	-
		-	0468 500 002	0468 599 002	0468 500 002	0468 500 002	-
		0.8	0468 500 003*	0468 500 003*	0468 500 003*	0468 500 003*	-
		0.9	0468 500 004*	0468 500 004	0468 500 004	0468 500 004	-
		1.0	0468 500 005*	0468 500 005*	0468 500 005*	0468 500 005*	-
		1.2	0468 500 007*	0468 500 007*	0468 500 007* (305)	0468 500 007*	-
		1.4	-	0468 500 008	0468 500 008*	0468 500 008*	-
		1.6	-	-	0468 500 009	0468 500 009	-
		-	-	-	0468 500 010	0468 500 010	-
		1.6	-	-	-	-	-
		1.6	-	-	-	-	-
		Contact tip		M8 x 37 CuCrZr			
CO₂	Mix/Ar	0.8	-	-	0468 502 003*	0468 502 003*	0468 502 003*
		0.9	-	-	0468 502 004*	0468 502 004	0468 502 004
		1.0	-	-	0468 502 005*	0468 502 005*	0468 502 005*
		1.2	-	-	0468 502 007* (410w/CW)	0468 502 007* (405/405C)	0468 502 007*
		1.4	-	-	0468 502 008*	0468 502 008*	0468 502 008*
		1.6	-	-	0468 502 009	0468 502 009 (510w)	0468 502 009
		-	-	-	0468 502 010	0468 502 010	0468 502 010
		2.0	-	-	-	0468 502 011 (510w)	0468 502 011
		2.4	-	-	-	0468 502 012 (510w)	0468 502 012
		2.4	-	-	-	-	-
Contact tip		Please see main brochure or manual					
Liner Steel liner for non- alloyed and cored wires.	0.6 - 0.8 0.9 - 1.0 1.2 1.4 1.6 2.0 2.4	3 m/4.5 m	3 m/4.5 m	3 m/4.5 m	3 m/4.5 m	3 m/4.5 m	
		0366 549 882/883	0366 549 882/883	0366 549 882/883	0366 549 884/885	0366 549 882/883	-
		0366 549 884/885	0366 549 884/885	0366 549 884/885	0366 549 884/885	0366 549 884/885	0366 549 884/885
		0366 549 886/887	0366 549 886/887	0366 549 886/887	0366 549 886/887	0366 549 886/887 (405/405C)	0366 549 886/887
		-	-	0366 549 888/889	0366 549 888/889	0366 549 888/889	0366 549 888/889
		-	-	0366 549 890/891	0366 549 890/891	0366 549 890/891 (510w)	0366 549 890/891
		-	-	-	-	0366 549 898 (4.5 m – 510w)	0366 549 898 (4.5 m)
-	-	-	-	0366 549 899 (4.5 m – 510w)	-		
Liner PTFE liner for Fe, Ss, Al	0.6 0.8 0.9 - 1.0 1.2 1.4 1.6 2.0/2.4	0366 550 880/881	0366 550 880/881	-	-	-	
		-	0366 550 882/883	0366 550 882/883	0366 550 882/883	0366 550 882/883	-
		-	0366 550 884/885	0366 550 884/885	0366 550 884/885	0366 550 884/885	0366 550 884/885
		-	0366 550 886/887	0366 550 886/887	0366 550 886/887	0366 550 886/887	0366 550 886/887
		-	-	0366 550 888/889	0366 550 888/889	0366 550 888/889	0366 550 888/889
		-	-	0366 550 890/891	0366 550 890/891	0366 550 890/891	0366 550 890/891
PTFE liner beige Full length without wear insert	1.0-1.2	0457 969 882/883	0457 969 882/883	0457 969 882/883	0457 969 882/883	0457 969 882/883	
	1.4-1.6	-	-	0457 969 884	0457 969 884	0457 969 884	

* Articles marked with * available in 100-pack. Only change position seven in the article number. Ex. 0468 500 003 become 0468 500 303.

MIG/MAG equipment

MXL Torches

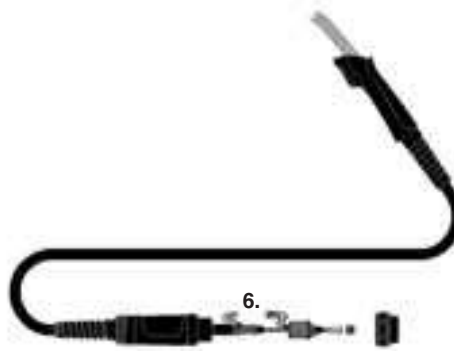
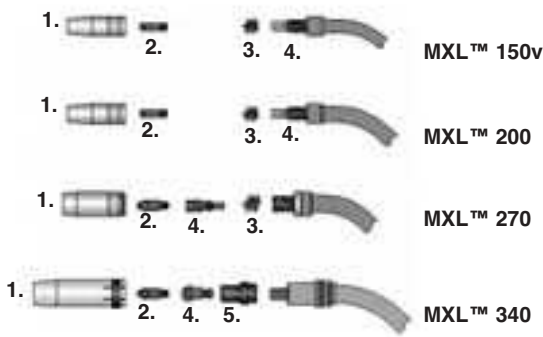

1.	MXL™ 150v	MXL™ 200	MXL™ 270	MXL™ 340
Gas nozzle standard Ø12 mm	0700 200 054	0700 200 054		
Gas nozzle standard Ø15 mm			0700 200 055	
Gas nozzle standard Ø16 mm				0700 200 056
Gas nozzle straight Ø16 mm	0700 200 057	0700 200 057		
Gas nozzle straight Ø18 mm			0700 200 058	
Gas nozzle straight Ø19 mm				0700 200 059
Gas nozzle conical Ø 9.5 mm	0700 200 060	0700 200 060		
Gas nozzle conical Ø11.5 mm			0700 200 061	
Gas nozzle conical Ø12 mm				0700 200 062
2.				
Contact tip Cu W0.6 M6	0700 200 063	0700 200 063		
Contact tip Cu W0.8 M6	0700 200 064	0700 200 064		
Contact tip Cu W0.9 M6	0700 200 065	0700 200 065		
Contact tip Cu W1.0 M6	0700 200 066	0700 200 066		
Contact tip Cu W0.8 M6			0700 200 068	0700 200 068
Contact tip Cu W0.9 M6			0700 200 069	0700 200 069
Contact tip Cu W1.0 M6			0700 200 070	0700 200 070
Contact tip Cu W1.2 M6			0700 200 071	0700 200 071
3.				
Nozzle spring	0700 200 078	0700 200 078		
Nozzle spring			0700 200 079	
4.				
Tip adaptor M6 MXL™ 150v	0700 200 076			
Tip adaptor M6 MXL™ 200		0700 200 072		
Tip adaptor M6 MXL™ 270			0700 200 073	
Tip adaptor M6-Alu MXL™ 270			0700 200 067	
Tip adaptor M6, short MXL™ 340				0700 200 074
Tip adaptor M6, long MXL™ 340				0700 200 075
5.				
Gas diffusor				0700 200 080
6.				
Steel liner W0.6 - W0.8 2.5 m	0700 200 099			
Steel liner W0.6 - W0.8 3.0 m		0700 200 085	0700 200 085	0700 200 085
Steel liner W0.6 - W0.8 4.0 m		0700 200 086	0700 200 086	0700 200 086
Steel liner W0.9 - W1.2 3.0 m		0700 200 087	0700 200 087	0700 200 087
Steel liner W0.9 - W1.2 4.0 m		0700 200 088	0700 200 088	0700 200 088
PTFE liner W0.6 - W0.8 3.0 m		0700 200 089	0700 200 089	0700 200 089
PTFE liner W0.6 - W0.8 4.0 m		0700 200 090	0700 200 090	0700 200 090
PTFE liner W0.9 - W1.2 3.0 m		0700 200 091	0700 200 091	0700 200 091
PTFE liner W0.9 - W1.2 4.0 m		0700 200 092	0700 200 092	0700 200 092

Control panels



M11/M12

- Adjustable burn-back timer
- Creep start
- 2/4 stroke
- Wire feed speed
1.9-20 m/min (M11)
1.9-25 m/min (M12)



MA23

- CC/CV
- Digital meter
- 3 memories
- 2-4 stroke
- Inductance setting
- Manual gas purge and wire feeding
- Remote control



M13

- Additional functions to M12
- Crater filling

M13 V/A

- Additional functions to M13
- * Digital V/A meter



MA23A

- Additional functions to MA23
- QSet™
 - Spot welding



TA23

- Slope up
- Welding current
- Slope down
- Gas post flow time



A2

- Current
- Arc force



TA24

- Slope up
- Welding current
- Pulse time
- Background current
- Background time
- Slope down
- Gas post flow time



A4

- Additional functions to A2:
- Hot start
 - Display measurement V/A
 - Electrode type



TA24 AC/DC

- Slope up
- Welding current
- Pulse time
- Background current
- Background time
- Slope down
- Gas post flow time
- AC balance
- AC Frequency
- Electrode preheating



TA4

- TIG/MMA
- MMA arc force, hot start
- Gas pre/post flow
- Slope up/down
- HF/Lift Arc
- 2/4 stroke
- Display measurement V/A

Control panels



TA6

- Additional functions to TA4:
- MMA: electrode type
 - Gas purge
 - 10-memory program
 - Pulsing DC



U6

U6 contains all features from MA6 and TA6



MA4

- MIG/MAG
- Voltage
- Wire feed speed
- Burnback timer
- 2/4 stroke
- MMA arc force, hot start
- Inductance, stepless
- Gas pre/post flow
- Crater filling
- Creep start
- Display measurement V/A



Aristo™ U8

Aristo™ U8 is a complete, fully equipped programming unit as well as a user friendly control pendant used with the panel M0.



MA6

- Additional functions to MA4:
- Synergy MIG/MAG
 - Synergy pulse MIG/MAG
 - MMA: electrode type
 - 10 memory positions
 - Hot start MIG
 - Gas purge
 - Wire inching
 - Multi language



TA33 AC/DC

- Display
- Welding method MMA/TIG*
- Welding process AC/DC, DC-, AC MMA
- HF/Liftarc start
- 2-4 stroke
- Panel/remote
- Plate thickness
- Slope down
- Post gas
- Reversed output by knob in MMA

Multi Voltage units

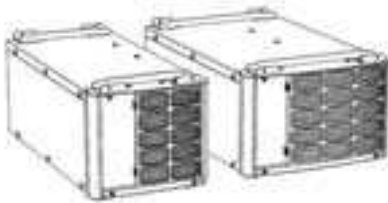

TA34 AC/DC

- Slope up
- Welding current
- Pulse time
- Background current
- Background time
- Slope down
- Gas post flow time
- AC balance
- AC Frequency
- Electrode preheating

Ordering information

Multi Voltage unit TUA 1, Aristo™ and Origo™ Arc	0459 144 880
Handle incl. mounting screws for separate installation (Complete set = 2)	0459 307 880
Multi Voltage unit TUA 2, Aristo™ Mig and Aristo™ Tig	0459 145 880
Handle incl. mounting screws for separate installation (Complete set = 2)	0459 307 881

Trolleys

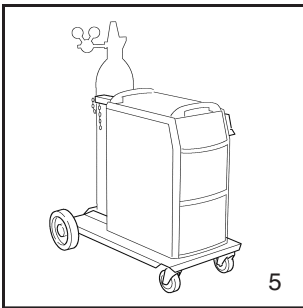
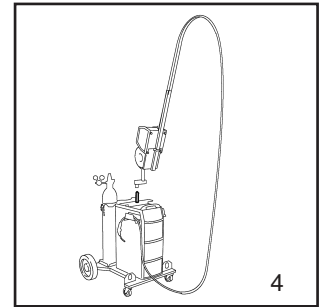
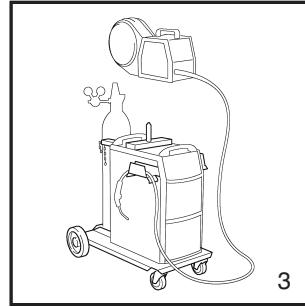
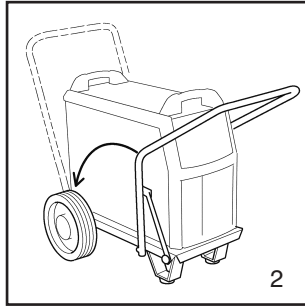

ESAB has a wide range of different trolleys to facilitate the welding and to increase the working radius.

Ordering information

	Caddy™ Arc Caddy™ Tig Origo™ Tig Origo™ Arc	Mech Tig 4000iw	Mech Tig C2002i	Aristo™ Mig 4500i	Aristo™ Arc Origo™ Arc 4000i/5000i	Aristo™ Mig 4000i/ 5000i	Aristo™ Tig 4000i Origo™ Tig 4300iw AC/DC	Origo™ Mig C3000i/ L3000i	Aristo™ Mig C3000i/ L3000i	Origo™ Tig 3000i Origo™ Tig 3000i AC/DC	Caddy™ Tig 2200i AC/DC
1. 0301 100 880			•								
2. 0458 525 880					•						
3. 0458 530 880		•				•					
4. 0458 603 880						•					
5. 0458 530 881							•				
6. 0459 366 880	•										
6. 0459 366 885											•
7. 0459 366 881	•										
7. 0459 366 886											•
8. 0459 366 890								•	•	•	
9. 0460 060 880								•	•	•	
10.0460 330 880											•

Ancillary equipment

Remote controls

Recommendation table – combinations of remote controls and power sources and feeders.

Process	Description	MTA1 CAN	M1 10P CAN	AT1 CAN	AT1 CF CAN	M1	AT1	AT1 CF	RA12	RA23	FS002 CAN	FS002	T1 Foot CAN	MIG 2	MMA 1	MMA 2
MMA	LHF						•	•							•	•
MMA	Caddy™ Professional						•	•							•	•
MMA	Caddy™ Arc						•	•							•	•
MMA	Origo™ Arc A2	•		•	•				•							
MMA	Aristo™ Arc A4	•		•	•				•							
TIG/MMA	Caddy™ Tig 150i/200i						•	•				•			•	•
TIG/MMA	Aristo™ Tig TA4	•		•	•				•		•					
TIG/MMA	Aristo™ Tig TA6	•	•	•	•				•		•					
TIG/MMA	Caddy™ Tig 2200i			•	•								•			
TIG/MMA	Origo™ Tig TA24			•	•								•			
TIG/MMA	Origo™ Tig TA24 AC/DC			•	•								•			
TIG/MMA	Origo™ Tig TA23			•	•								•			
MIG/MAG	Origo™ Feed M12					•								•		
MIG/MAG	Origo™ Feed M13					•								•		
MMA/MIG/MAG	Aristo™ Feed MA4	•		•	•					•						
MMA/MIG/MAG	Aristo™ Feed MA6	•	•	•	•				•	•						
TIG/MMA/MIG/MAG	Aristo™ Feed U6	•	•	•	•				•	•	•					
TIG/MMA/MIG/MAG	Aristo™ Feed M0 / U8	•	•	•	•				•	•	•					
MMA/MIG/MAG	Aristo™ YardFeed 2000	•	•													

Ordering information

CAN based:

Cable, 5 m CAN + Amphenol 10p	0459 960 880
Cable, 5 m CAN + Burndy 12	0459 554 880
Cable, 10 m CAN + Burndy 12	0459 554 881
Cable, 15 m CAN + Burndy 12	0459 554 882
Cable, 25 m CAN + Burndy 12	0459 554 883
Cable, 0.25 m CAN + Burndy 12	0459 554 884
Cable, 5 m CAN + Amphenol 10	0459 960 980 (HD version)
Cable, 5 m CAN + Burndy 12	0459 554 980 (HD version)

Analogue:

Cable, 5 m, analogue, Burndy 23	0459 553 880
Cable, 5 m, analogue, Burndy 12	0459 552 880
Cable, 10m, analogue, Burndy 12	0459 552 881
Cable, 15m, analogue, Burndy 12	0459 552 882
Cable, 25m, analogue, Burndy 12	0459 552 883



AT1 CAN

CAN based standard remote control for MMA and TIG. Suitable for control panel A2, A4, TA4, TA6, TA23 and TA24
MMA/TIG: Current control.

Ordering information

AT1 CAN 0459 491 883



AT1 CoarseFine CAN

CAN based standard remote control for MMA and TIG. Suitable for control panel A2, A4, TA4, TA6, TA23 and TA24
MMA/TIG: Current control, coarse/fine.

Ordering information

AT1 CoarseFine CAN 0459 491 884



MTA1 CAN

CAN based multi function remote control for the control panels A2, A4, TA4, TA6, MA4, MA6, MA23, MA23A, U6 and Aristo™ U8.
MMA: Knob 1, Current control Knob 2, Arc force
TIG: Knob 1, Pulse current Knob 2 Back-ground current

Ordering information

MTA1 CAN 0459 491 880

Ancillary equipment

Remote controls



M1 10Prog CAN

CAN based standard remote control Synergic MIG. Suitable for control panel MA6, U6 and Aristo™ U8. MIG/MAG: Memory 1-10 and voltage trim +/-.

Ordering information

M1 10Prog CAN 0459 491 882



FS 002 CAN

Foot pedal for starting and stopping as well as for stepless current setting. Max. current can also be set using a potentiometer. Used mostly for TIG welding.

Ordering information

FS 002 CAN with 5 m of cable for Aristo™ Tig and Aristo™ Mig Universal 0349 090 890



FS 002

Foot pedal for starting and stopping as well as for stepless current setting. Max. current can also be set using a potentiometer. Used mostly for TIG welding.

Ordering information

FS 002 with 5 m of cable 0349 090 886



T1 Foot CAN

Foot pedal for starting and stopping as well as for stepless current setting. Max. current is set using a panel and min. current is set as a percentage of the max. current. Used mostly for TIG welding.

Ordering information

T1 Foot CAN 0460 315 880



AT1

Analogue standard remote control for MMA and TIG. Suitable for power sources with remote outlet. MMA/TIG: Current control.

Ordering information

AT1 0459 491 896



AT1 CoarseFine

Analogue standard remote control for MMA and TIG. Suitable for power sources with remote outlet. MMA/TIG: Current control, coarse/fine.

Ordering information

AT1 CoarseFine 0459 491 897

Ancillary equipment

Remote controls



M1

Analogue standard remote control. Suitable for MIG for control panel M10, M12 and M13. MIG/MAG: Wire feed and voltage control

Ordering information

M1 0459 491 895



Remote control MMA 1

The remote-control MMA 1 is equipped with one knob, giving the welder the opportunity steplessly to adjust the current. It comes with a 10-metre rubber cable with a 12-pole Burndy connector

and a metal hook for easy handling when not welding.

Ordering information

Remote control MMA 1 0349 501 024



Remote control MMA 2

The remote-control MMA 2 is equipped with two knobs, giving the welder the opportunity to make both rough and fine current settings. It comes with a 10-metre rubber cable with a 12-pole Burndy

connector and a metal hook for easy handling when not welding.

Ordering information

Remote control MMA 2 0349 501 025



Remote control MIG 2

The remote-control MIG 2 is equipped with a 23-pole connector and is suitable for MIG/MAG machines. With this remote, it is possible to set both current and voltage. It comes with a five-metre rubber

cable and a metal hook for easy handling when not welding.

Ordering information

Remote control MIG 2 0349 501 028



Remote Adapter 12

Remote adapter for CAN based systems. For analogue MMA and TIG remote controls.

Ordering information

RA 12 for MMA and TIG incl. holder 0459 491 910



Remote Adapter 23

Remote adapter for CAN based systems. For analogue MIG/MAG remote controls and 3-step program switch RS3.

Ordering information

RA 23 for MIG/MAG and RS3 incl. holder 0459 491 911

Ancillary equipment

Cooling units



CoolMini

Cooling unit suitable for TIG torches. Working together with Tig 2200i.

	CoolMini
Cooling water, l/min	2
Max water pressure, bar	2.3
External dimensions, LxWxH, mm	407x187x137
Weight, kg	5/7

Ordering information

Cooling unit, CoolMini 0460 144 880
 ESAB coolant 10 l. 0194 230 002



CoolMidi 1800

Cooling unit suitable for MIG and TIG torches. Working together with Tig 3000i, Tig 3000i AC/DC, Mig 3000i and Mig C3000i.

	CoolMidi 1800
Mains supply, V/Hz	400, 3~50/60
Cooling water, l/min	4
Max water pressure, bar	3/3.8
External dimensions, LxWxH, mm	710x385x208
Weight, kg	19/23

Ordering information

CoolMidi 1800 0459 840 880
 ESAB coolant 10 l. 0194 230 002

Ancillary equipment

Cooling units



OCE-2 H

The OCE-2 H water-cooling unit is an efficient, compactly-dimensioned cooling unit designed for use together with water-cooled equipment for arc welding by hand or in automatic plants. The water tank and pump are made of stainless corrosion-resistant material.



OCE-2 H

Mains supply, V/Hz	230/50-60
Cooling water, l/min	6.0
Max water pressure, bar	2.8
External dimensions, LxWxH, mm	320x270x360
Weight, kg	15

Ordering information

OCE-2 H	0414 191 881
Flow guard to OCE-2 H	0414 231 880
ESAB coolant 10 l.	0194 230 002

Manual plasma cutting equipment

Plasma cutting packages



OrigoCut 35i

OrigoCut is a small and portable, single phase 230 V, plasma cutting package. Perfect for repair and maintenance. Cuts all metals, including copper and aluminium. Mild steels up to 12 mm can be separated. Few settings makes it easy to use. Just add electricity and compressed air. The powerful HF start goes straight through a drawing, placed or glued on top of the plate – cuts the exact part you need.

Delivery includes

OrigoCut, 4.5 m PT 31XL torch, 5 m return lead, 2.5 m mains cable with Schuko plug, carrying strap and wear part kit.

OrigoCut 35i

Mains supply, V/Hz	230/50
Fuse, slow, A	16
Mains cable, Ø mm ²	3x1.5
Max output at 35% duty cycle, A	35
Max output at 60% duty cycle, A	27
Max output at 100% duty cycle, A	21
Setting range, A	15-35
Open circuit voltage, V	270
Air, l/min	120
Pressure, bar	5.5
Cutting capacity, Fe mm	10/12
Cutting capacity, SS mm	6/8
Cutting capacity, Al mm	10/12
Weight, kg	9

Ordering information

OrigoCut 35i , CE, 4.5 m torch, 1ph 230 V 0558 005 920



POWERCUT® 650

POWERCUT® 650 is a very powerful plasma cutting package in a tough casing, making it suitable for most plasma cutting applications. It cuts mild steel with quality from thin plate up to 16mm (severs 19mm). It also cuts aluminium and stainless steel.

Delivery includes

The POWERCUT® 650 comes out of the box ready to use. The torch PT-31XLPC is attached with parts in place, primary cord is attached and the filter regulator is installed. Just hook up the air, plug it in and cut. Start-up wear parts kit included.

POWERCUT® 650

Mains supply, V/Hz	230 (1/3ph) and 400 (3ph)/50
Fuse, slow, A	16
Max output at 40% duty cycle, A	40
Setting range, A	10-40
Open circuit voltage, V	290
Air, l/min	165
Pressure, bar	5.5
Cutting capacity, Fe mm	16/19
Cutting capacity, SS mm	12/16
Cutting capacity, Al mm	16/20
Weight, kg	25

Ordering information

POWERCUT® 650 230V 1/3ph with 7.6m PT-31XLPC	0558 004 800
POWERCUT® 650 400V 3ph with 7.6m PT-31XLPC	0558 004 801
Optional accessories & wear parts	
Wheel kit	0558 003 399
Torch wrap	0558 003 398
Torch PT-31XLPC, 7.6m	0558 005 393
Wear part kit PT-31XLPC	0558 005 392
Deluxe torch guide kit	0558 003 258
Basic guide kit	0558 002 675
Plasma flow measuring kit	0558 000 739

Manual plasma cutting equipment

Plasma cutting packages



POWERCUT® 875

POWERCUT® 875 is a very powerful plasma cutting package in a tough casing, making it suitable for most plasma cutting applications. It cuts mild steel from thin plate up to 32mm, and also cuts aluminium and stainless steel.

Delivery includes

The POWERCUT® 875 comes out of the box ready to use. The torch PT-32EH is attached with parts in place, primary cord is attached and the filter regulator is installed. Just hook up the air, plug it in and cut. Start-up wear parts kit included.

POWERCUT® 875

Mains supply, V/Hz	230 (3ph) and 400 (3ph)/50
Fuse, slow, A	20
Max output at 60% duty cycle, A	60
Setting range, A	20-60
Open circuit voltage, V	275
Air, l/min	165
Pressure, bar	5.5
Cutting capacity, Fe mm	22/32
Cutting capacity, SS mm	15/22
Cutting capacity, Al mm	22/32
Weight, kg	40

Ordering information

POWERCUT® 875 230V CE with 7.6 m PT-32EH	0558 004 942
POWERCUT® 875 230V CE with 15.2 m PT-32EH	0558 005 167
POWERCUT® 875 400V CE with 7.6 m PT-32EH	0558 004 940
POWERCUT® 875 400V CE with 15.2 m PT-32EH	0558 005 168
Optional accessories	
Wheel kit	0558 003 014
Torch wrap	0558 003 013
Torch PT-32EH (ergonomic handle), 7.6m	0558 003 548
Torch PT-32EH (ergonomic handle), 15.2 m	0558 003 549
Wear part kit PT-32EH	0558 004 949
Deluxe torch guide kit	0558 003 258
Basic guide kit	0558 002 675
Plasma flow measuring kit	0558 000 739



POWERCUT® 1500

A powerful and robust plasma cutting package for high production cutting rates. Fitted with the ergonomic PT 32EH torch with very long wear part life. Cuts up to 38 mm mild steel and sever 45 mm. For highspeed production cutting, we recommend approx. 18 mm. Trigger lock function for long cuts.

Delivery includes

PT 32EH torch, return lead with clamp, mains cable, wear part kit and regulator with filter.

POWERCUT® 1500

Mains supply, V/Hz	400/50
Fuse, slow, A	25
Mains cable, Ø mm ²	4x6
Max output at 60% duty cycle, A	90
Setting range, A	20-90
Open circuit voltage, V	289
Air, l/min	165
Pressure, bar	5
Cutting capacity, Fe mm	38/40
Cutting capacity, SS mm	20/29
Cutting capacity, Al mm	38/45
Weight, kg	43

Ordering information

POWERCUT® 1500, CE, 7.5 m torch, 400 V	0558 001 945
POWERCUT® 1500, CE, 15 m torch, 400 V	0558 001 946
POWERCUT® 1500, CE, 7.5 m torch, 400 V, delivered with torch wrap and wheel kit	0558 004 128
Optional accessories	
PT 32EH torch, 15 m	0558 003 549
Torch wrap kit	0558 003 059
Wheel kit	0558 003 060

Manual plasma cutting equipment

Plasma cutting packages



ESP 150

This heavy-duty, water-cooled plasma cutting and gouging system provides the perfect solution for production cutting and plasma gouging.

The ESP 150 can cut up to 51 mm manually and can sever 63 mm, using either an Ar/H₂ mixture or compressed air.

Gas options for higher quality cuts, especially on aluminium and "stainless", resulting in lower total operating costs – the PT 26 torch cuts with nitrogen or argon-hydrogen mixtures; choice of carbon dioxide, air, nitrogen or oxygen for torch cooling.

Delivery includes

The ESP 150 package includes a 7.6 m leather protected PT 26 torch, torch wear part kit, 7.6 m work cable, dual cylinder rack/wheel kit, regulators/filters, torch hooks, torch coolant and gas hose.



ESP 150

Mains supply, V/Hz	400/50
Fuse, slow, A	70
Mains cable, Ø mm ²	4x25
Max load at 100% duty cycle, A	140
Setting range, A	50-150
Open circuit voltage, V	370
Air, l/min	113/95/95
Pressure, bar	7/7/7
Cutting capacity, Fe mm	40/50
Cutting capacity, SS mm	25/38
Cutting capacity, Al mm	40/50
Weight, kg	308

Ordering information

ESP 150, CE, 7.5 m torch, 400 V	0558 003 472
Optional accessories	
Torch PT 26, 70°, 15 m	0558 002 209
Torch PT 26, INLINE, mech, 7.6 m	0558 002 320
Torch PT 26, INLINE, mech, 15 m	0558 002 321
Remote hand switch	0558 003 796
Leather protection for torch hose 7.6 m	0558 002 921
Leather protection for torch hose 15 m	0558 002 922

Manual plasma cutting equipment

Plasma cutting packages



LPH 35 handy cut

Designed for repair work and small workshops. Ideal when a small, effective and easy-to-transport plasma cutting unit is needed.

2 step control for easier setting – thinner or thicker materials. Built-in manometer makes air pressure control fast and easy.

Delivery includes

Torch PT 30 KK, return cable with clamp, stand-off guide

* sever capacity

	LPH 35	LPH 35
Mains supply, V/Hz	3x230, 50/60	3x400-415, 50/60
Fuse, slow, A	28	16
Mains cable, Ø mm ²	4x2.5	4x1.5
Max output at 35% duty cycle, A	35	35
Max output at 100% duty cycle, A	20	20
Setting range, A	20-35	20-35
Open circuit voltage, V	295	295
Air, l/min	130	130
Pressure, bar	3.5-4.5	3.5-4.5
Cutting capacity, Fe mm	6/12*	6/12*
Cutting capacity, SS mm	6/10*	6/10*
Cutting capacity, Al mm	6/12*	6/12*
Weight, kg	53	52

* sever capacity

Ordering information

LPH 35, 3x400-415V, 50/60Hz

0457 288 880

LPH 35, 3x230V, 50/60Hz

0457 288 881



LPH 50 power cut

A plasma cutting unit designed for small workshops and industrial users. 7.6 m long torch, wheels and handle makes it easy to reach the work at hand. Two step control for easier setting – thinner or thicker materials.

Cuts gratings without any additional accessory.

Delivery includes

PT 27 torch, return cable with clamp, stand-off guide

* sever capacity

	LPH 50	LPH 50
Mains supply, V/Hz	3x400/415, 50/60	3x230/400-415/440
Fuse, slow, A	24	42/24/22
Mains cable, Ø mm ²	4x2.5	4x6
Max output at 60% duty cycle, A	50	50
Max output at 100% duty cycle, A	30	30
Setting range, A	30-50	30-50
Open circuit voltage, V	320	320
Air, l/min	118	118
Pressure, bar	4.5-7	4.5-7
Cutting capacity, Fe mm	12/15*	12/15*
Cutting capacity, SS mm	8/12*	8/12*
Cutting capacity, Al mm	8/15*	8/15*
Weight, kg	89	90

Ordering information

LPH 50, 3x400-415V, 50/60Hz

0457 289 880

LPH 50, 3x230V/400-415V/440V, 50-60Hz

0457 289 881

Manual plasma cutting equipment

Plasma cutting packages



LPH 80 power cut

Designed for industrial users who require good plasma cutting performance at an attractive price. Easy to move thanks to a well-positioned handle and 4 wheels. 3 step control for easier setting – thinner medium or thicker material. Can cut gratings without any additional accessory.

Delivery includes

7.6 m PT 27 torch, return cable with clamp, stand-off guide, filter/regulator and wheels

	LPH 80
Mains supply, V/Hz	3x400-415, 50/60
Fuse, slow, A	29
Mains cable, Ø mm ²	4x4
Max output at 60% duty cycle, A	80
Max output at 100% duty cycle, A	60/40
Setting range, A	40-80
Open circuit voltage, V	310
Air, l/min	118
Pressure, bar	4.5-7
Cutting capacity, Fe mm	25/35*
Cutting capacity, SS mm	20/25*
Cutting capacity, Al mm	22/30*
Weight, kg	131

* sever capacity

Ordering information

LPH 80, 3x400-415V, 50/60Hz 0457 290 880



LPH 120 power cut

Designed for industrial users who require heavy-duty plasma cutting performance at an attractive price. Easy to move, thanks to well-positioned handle, 4 wheels and lifting eyelets. 3 Step control for easier setting – thin, medium or thick materials. Cuts gratings without any additional accessory. Also superb for gouging applications.

Delivery includes

7.6 m PT 25 torch, return cable with clamp, stand-off guide, regulator/filter and wheels

	LPH 120	LPH 120
Mains supply, V/Hz	3x400-415, 50/60	3x230/400-415/440, 50/60
Fuse, slow, A	45	78/45/41
Mains cable, Ø mm ²	4x6	4x16
Max output at 60% duty cycle, A	120	120
Max output at 100% duty cycle, A	90/60	90/60
Setting range, A	60-120	60-120
Open circuit voltage, V	310	310
Air, l/min	186/236	180/236
Pressure, bar	4.9-7	4.9-7
Cutting capacity, Fe mm	35/40*	35/40*
Cutting capacity, SS mm	25/25*	25/25*
Cutting capacity, Al mm	28/30*	28/30*
Weight, kg	167	167

* sever capacity

Ordering information

LPH 120, 3x400-415V, 50/60Hz 0457 291 880
 LPH 120, 3x230V/400-415V/440V, 50/60Hz 0457 291 881

Manual plasma cutting equipment



Plasma torches



Plasma gouging

Plasma gouging is an effective way of removing material, when preparing for the next layer to be welded or for removing faults. Generally speaking, the advantages of using plasma instead of carbon rods are 50% less noise, 50% fewer particles in the air, 50% less energy consumed, no carbon deposits in the material and the fact that gouging can be performed on all materials (even high-alloyed and aluminium).

Only two parts need to be changed (no tools needed) to gouge instead of cut – the nozzle and an additional metal gouging heat shield.

Ordering information

Gouging nozzle, PT 25	0558 000 729
Gouging shield, PT 25	0558 000 737
Gouging nozzle, PT 27	0558 000 480
Gouging shield, PT 27	0558 000 481
Gouging nozzle, PT 32EH	0558 003 089
Gouging shield, PT 32EH	0558 003 090



Wear part kits

These wear part kits organize your plasma cutting wear parts for more efficient handling. Includes: electrodes, swirl baffle, nozzles, heat shield etc.

Ordering information

Wear parts kit, PT 25	0558 000 742
Wear parts kit, PT 26	0558 002 864
Wear parts kit, PT 27, 60 A	0558 000 488
Wear parts kit, PT 27, 70 A	0558 003 466
Wear parts kit, PT 27, 80 A	0558 000 489
Wear parts kit, PT 30 KK	0457 288 168
Wear parts kit, PT 31XL, 35 A	0558 003 462
Wear parts kit, PT 31XL, 50 A	0558 003 464
Wear parts kit, PT 32EH, 90 A	0558 003 557



Torch guide kits

The deluxe guide kit can be used for straight line, circular (45 to 1050 mm) or bevel plate edge preparations. Position using pin on rivot mark, magnet or suction cup. The same kit can be used for torches PT 17, 23, 25, 27, 31XL, 32EH and 34. A basic kit for plasma cutting torches PT 17, 23, 25, 27, 31XL, 32EH and 34 with circular guide (45 to 750 mm) using pin on rivot mark is also available.

Separate two wheel guide kits are available for PT 31XL and PT 27.

Ordering information

Deluxe cutting guide kit, PT 17, 23, 25, 27, 31XL, 32EH and 34	0558 003 258
Basic circle guide kit, PT 23, 27, 31XL, 32EH	0558 002 675
2-wheel guide PT 31XL	0558 000 947
2-wheel guide PT 27	0558 000 943



PT 25

Plasma cutting torch PT 25 is designed for heavy-duty cutting and gouging operations. Can use compressed air or two different gases simultaneously; one as the cutting gas, the other as the cooling gas. Rated at 150 A in continuous operation. This torch is used on LPH 120 and ESP 100i.

Ordering information

PT 25, 7.6 m torch	0558 000 724
PT 25, 15 m torch	0558 000 725
Heat shield	0558 000 730
Nozzle, 100 (120) A	0558 000 727
Swirl baffle, ESP 100i	0558 000 735
Electrode, compr. air or N ₂	0558 000 732
Electrode, Ar-H ₂	0558 000 733
Electrode holder	0558 000 731
O-ring	0558 000 734
Gouging nozzle	0558 000 729
Gouging shield	0558 000 737
Swirl baffle, LPH 120	0558 001 457



PT 26

This versatile, easy-to-use, 300 Amp, water-cooled plasma cutting torch provides superior performance for a full range of manual and mechanised cutting. Available in a manual version and a mechanised version (IN-LINE). Used on ESP 150.

Ordering information

PT 26, 70°, 7.6 m	0558 002 208
PT 26, 70°, 15 m	0558 002 209
PT 26, IN-LINE, 7.6 m	0558 002 320
PT 26, IN-LINE, 15 m	0558 002 321
Electrode, air N, N/H	0558 003 722
Electrode Ar/H (H35)	0558 003 723
Nozzle, 150 A, with O-ring	0558 003 717
Nozzle, gouging, with O-ring	0558 003 718
Heat shield	0558 003 714
Stand-off guide	0558 003 713
Remote hand switch	0558 003 796
Baffle tube with O-ring	0558 003 708
Insulator with O-ring	0558 003 711
Torch head with O-ring PT 26	0558 003 719

Manual plasma cutting equipment

Plasma torches



PT 27

The plasma cutting torch PT 27 is a rugged, compact, small-size, high-capacity torch. Made to be used with up to 80 A in continuous operation.

Produces clean, exceptionally fine cuts. Normally used with pilot arc.

PT 27 is used on LPH 50, LPH 80, HandyPlasma 70, PCM 875 and PCM 1000i.

Ordering information

PT 27, 7.6 m torch	0558 000 487
PT 27, 15 m torch	0558 000 490
Heat shield	0558 000 486
Nozzle, 50-70 A	0558 000 363
Nozzle, 80 A	0558 000 457
Swirl baffle	0558 000 365
Electrode	0558 000 364
Seat and valve assembly	0558 003 032
Torch body with O-ring and seat	0558 000 477
O-ring	0558 000 425
Gouging nozzle	0558 000 480
Gouging shield	0558 000 481



PT 30 KK

The PT 30 KK is a compact plasma torch where the pilot arc is generated without HF. Rated at 30 A at 60% and 50 A at 35% duty cycle. This torch is used on LPH 35.

Ordering information

PT 30 KK, 4 m torch	0457 288 001
Stand-off guide, metal wire	0457 288 150
Cap (heat shield)	0457 288 151
Spring	0457 288 152
Nozzle	0457 288 153
Insulating sleeve	0457 288 154
Electrode	0457 288 155
Torch body	0457 288 156
Safety clamp	0457 288 157
Multiple wrench	0457 288 158
Electrode wrench	0457 288 159
Stand-off guide, solid metal (optional)	0457 288 160



PT 31XL

The PT 31XL is the smallest 50 A plasma cutting torch on the market. Designed for superior operator comfort. Rated at 50 A in continuous operation. Specially-designed to make it easy to access places that are difficult to reach. For drag cutting with HF starts.

This torch is used on OrigoCut, Handy-Plasma 50 and PCM 500i.

Ordering information

PT 31XL, 7.6 m torch	0558 000 690
Heat shield	0558 000 509
Nozzle, 35/40 A	0558 000 508
Swirl baffle	0558 000 506
Electrode	0558 000 507
Plunger	0558 000 511
Replaceable seat	0558 000 510
Torch body	0558 000 790
Nozzle, 50 A	0558 000 513
PT 31XL, 4.5 m torch	0558 001 466
PT-31XLPC 7.6 m	0558 005 393



PT 32EH

This ergonomical, heavy-duty plasma cutting torch simplifies cutting. The two switches gives the operator the opportunity to choose the preferred position. Exceptionally long service life for wear parts increases productivity rates. This torch is used on POWERCUT® 1500.

Ordering information

PT 32EH, 7.6 m	0558 003 548
PT 32EH, 15 m	0558 003 549
Nozzle, 90 A	0558 002 837
Nozzle, 40 A	0558 002 908
Electrode	0558 001 969
Heat shield, long	0558 003 110
Valve pin	0558 001 959
Stand off guide	0558 002 393
Nozzle gouging	0558 003 089
Heat shield, drag	0558 003 374
Heat shield gouging	0558 003 090
Torch head with O-ring	0558 003 412
Heat shield, drag, heavy-duty	0558 004 206



***ESAB Welding Automation
for quality, productivity, working environment***

Orbital TIG welding

Welding heads orbital TIG



Introduction orbital TIG

New and improved metal qualities, rising material and labour costs, but also more sensitive materials, and continuously increasing demands on quality and productivity are factors which you have to deal with daily.

ESAB helps you to get ahead and stay ahead. Our metallurgists, chemists, engineers, technicians and skilled welders have one dedication: to find better materials and develop better equipment for your welding.

The ESAB welding program for mechanised tube welding is based on the TIG welding method with a non-consumable tungsten electrode.

To further improve weld quality and decrease costs, ESAB have developed micro-processor controlled power sources for orbital TIG welding, the Aristo™ MechTig C2002i and the Aristo™ MechTig 4000iw with control boxes Aristo™ MechControl 2 and 4.

A21 is ESAB's welding head for tube-to-tube welding, A22 is a welding head for tube-to-tube sheet welding and A25 is a modular component system for orbital TIG welding.

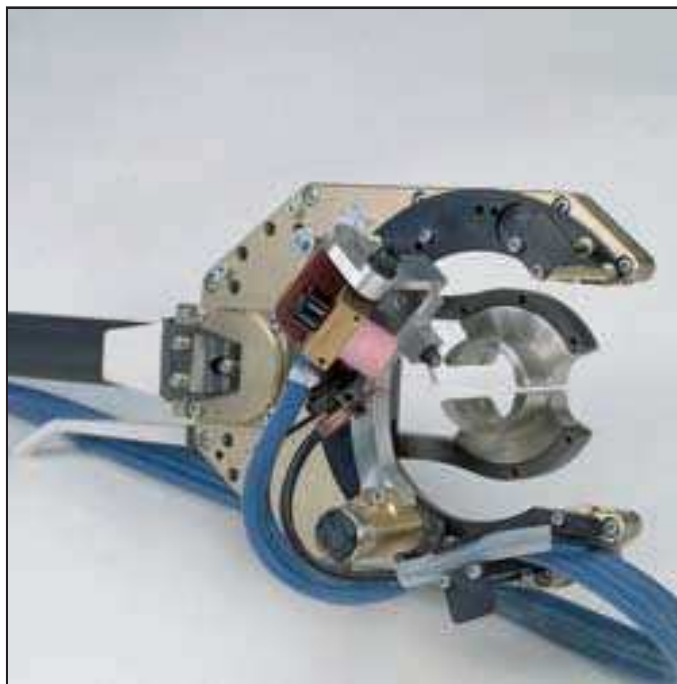

A21 PRB

The PRB welding head is compact and easy to use as a result of its unique pincer action which reduces setting-up times to a minimum. The welding head is positioned and secured around the tube with great accuracy in seconds. The PRB welding heads are available in three sizes for tubes with outer diameters of 17 to 170 mm.

Use these welding heads together with the Aristo™ MechTig power sources.

Delivery includes

7 m of connection cable (current, gas, water).

	PRB 17-49	PRB 33-90	PRB 60-170
Orbital speed, rpm	0.1-2.4	0.1-1.6	0.05-0.95
Tube diameters OD, mm	17-49	33-90	60-170
Max welding current, water, A	250	250	250
Max welding current, air, A	100	100	100
Electrode diameter, mm	1.6, 2.4	2.4, 1.6	2.4, 1.6
Weight, less cables, kg	2.8	3.2	4.4

Ordering information

PRB 17-49, water-cooled	0443 750 882
PRB 17-49, air-cooled	0443 750 883
PRB 33-90, water-cooled	0443 760 882
PRB 33-90, air-cooled	0443 760 883
PRB 60-170, water-cooled	0443 770 882
PRB 60-170, air-cooled	0443 770 883

Accessories for PRB:

Rebuilding kit for PRB/PRC 17-49 for welding tubes with outside diameters from 8-17 mm	0444 002 880
Rebuilding kit PRB/PRC 33-90 for welding tubes with outside diameters from 20-33 mm	0443 908 880
Rebuilding kit PRB/PRC 60-170 for welding tubes with outside diameters from 44-60 mm	0443 909 880
Wire holder complete with gas lense diameter 24 mm with adjustable wire nozzle for PRB/PRC 33-170	0443 923 880

Orbital TIG welding

Welding heads orbital TIG

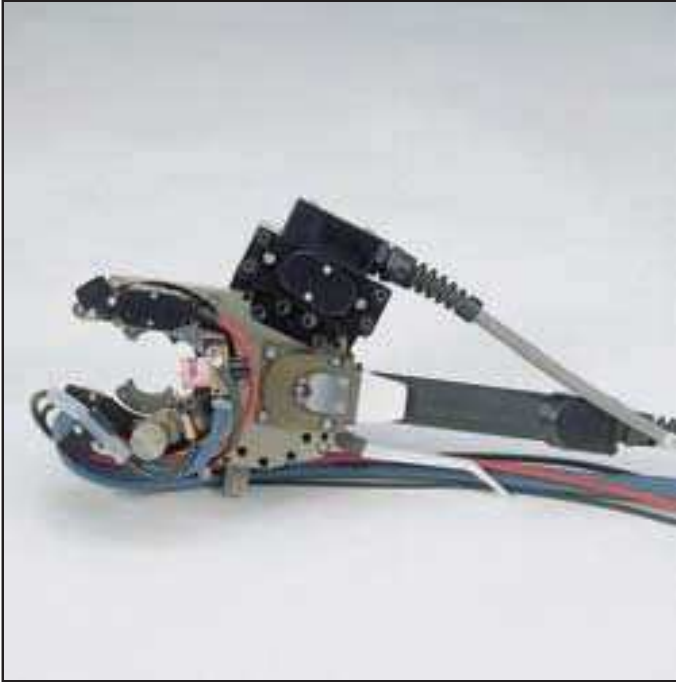

A21 PRC

The PRC welding head is a further development of our PRB welding head. The PRC features a zig-zag weaving movement and arc voltage control, which produces higher productivity and better welding quality, particularly when welding thick-walled tubes. These welding heads are used together with the Aristo™ MechTig power sources.

Delivery includes

7 m of connection cable (current, gas, water).

	PRC 17-49	PRC 33-90	PRC 60-170
Orbital speed, rpm	0.1-2.4	0.1-1.6	0.05-0.95
Tube diameters OD, mm	17-49	33-90	60-170
Max welding current, A	250	250	250
Weaving range, mm	20	20	20
Weaving reach, mm	7	7	7
Weaving speed, mm/s	1.0-12	1.0-12	1.0-12
Dwell time, s	0.1-10	0.1-10	0.1-10
Arc setting speed, mm/s	1.1	1.1	1.1
Weight with AVC and weave unit (less cables), kg	5.1	5.5	6.7

Ordering information

PRC 17-49 with AVC	0443 751 881
PRC 17-49 with AVC and weaving	0443 752 881
PRC 33-90 with AVC	0443 761 881
PRC 33-90 with AVC and weaving	0443 762 881
PRC 60-170 with AVC	0443 771 881
PRC 60-170 with AVC and weaving	0443 772 881



A21 PRD 100

The PRD 100 welding head is designed for precision, quality and technology of the highest class. It is a TIG welding head for tubes with an outer diameter of 100 mm and upwards. The PRD 100 is very compact in design and, as a result of its low profile, requires only 73 mm of clearance around the tube. The welding head is water-cooled and designed for amperage of up to 400 A. The mechanical settings are easy, all the welding parameters are incorporated in the procedure program which are controlled by a microprocessor system. Use this welding head together with the Aristo™ MechTig power sources.

Delivery includes

8 m of connection cable (current, gas, water) and motor cable.

	PRD 100
Orbital speed, cm/min	2-40
Tube diameters OD, mm	100 to flat
Electrode diameter, mm	1.0-4.0
Max welding current, A	400 (pulsed DC)
Weaving range, mm	+/-15
Weaving speed, mm/s	1-10
Dwell time, s	0.1-10
Arc voltage control amplitude, mm	25
Arc setting speed, mm/s	2.0
Weight, kg	8

Ordering information

PRD 100 welding head	0444 016 880
Racks and accessories, see page 63	

Orbital TIG welding

Welding heads orbital TIG

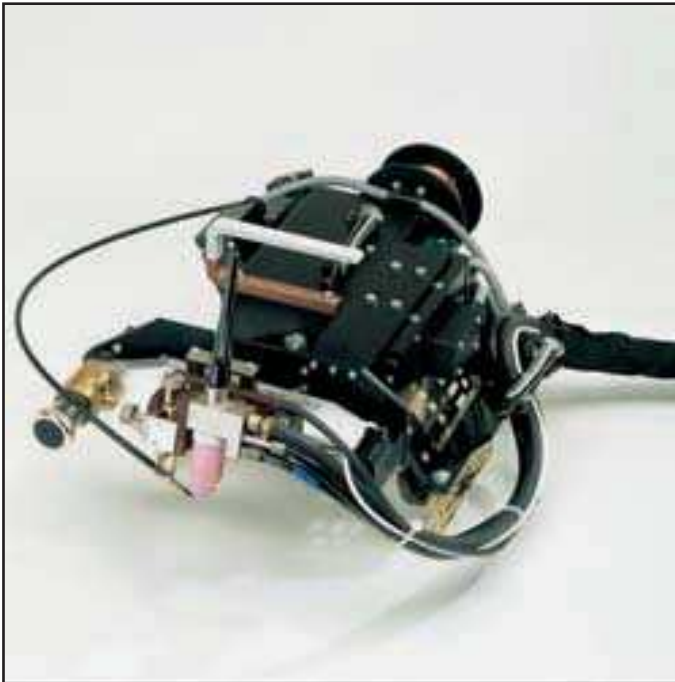

A21 PRD 160

The PRD 160 is a water-cooled flexible pipe-welding head, for pipes with an outer diameter of 160 mm and upwards. The PRD consists of an articulated carriage that travels around the pipe on a rack that is adapted to match the diameter of the pipe. To ensure maximum flexibility, the welding head is built in modules. The basic unit, for thin-walled pipes, includes only one motor, for travel. Depending on the application, it is possible to add wire-feed-, arc voltage control- and weaving-modules for the thicker wall applications. PRD 160 can be used together with the Aristo™ MechTig power sources.

Delivery includes

8 m of connection cable (current, gas, water) and motor cable.

	PRD 160
Orbital speed, cm/min	2-40
Tube diameters OD, mm	160-1025
Electrode diameter, mm	1.6-3.2
Max welding current, A	400 (pulsed DC)
Weaving range, mm	+/-15
Weaving speed, mm/s	2-12
Dwell time, s	0.1-10
Arc voltage control speed, mm/s	2.0
Weight, less cables and rack, kg	8

Ordering information

Basic unit intended only for fusion welding with a floating head	0444 151 880
Basic unit with wire feeder unit complete	0444 151 881
Basic unit with AVC (Arc Voltage Control)	0444 151 882
Basic unit with AVC plus wire feeder unit complete	0444 151 883
Basic unit with AVC plus wire feeder unit complete and weave unit	0444 151 884
Wire feeder unit complete	0444 137 880
AVC (Arc Voltage Control) complete	0443 656 881
Weave unit complete	0444 140 880
Racks and accessories, see page 63.	



A21 PRH

ESAB's PRH tube-welding tool is designed for welding thin-walled, stainless steel tubes in order to provide maximum gas shielding around the tube. The tool has been designed according to the chamber principle to produce this shield. This means that the rotating part and the Tungsten electrodes are enclosed in a gas chamber formed by the outer casing, which also constitutes the clamping arrangement for the tube to be welded. The tube-welding tool is water-cooled and forms a complete unit which also incorporates the return conductor. It is available in three sizes, PRH 3-12, PRH 3-38 and PRH 6-76, making it possible to weld tubes of between 3 mm and 76.2 mm.

All three heads are equipped with encoder motors for precise positioning of each sector when welding with different sets of parameters.

Delivery includes

8 m of connection cable (current, gas, water and return).

	PRH 3-12	PRH 3-38	PRH 6-76
Max output at 100% duty cycle, A	15	50	60
Orbital speed, rpm	0.65-12.6	0.5-9.5	0.31-6.15
Tube diameters OD, mm	3-12.7	3-38.1	6-76.2
Max welding current, water, A	40 (pulsed)	100 (pulsed)	100 (pulsed)
Electrode diameter, mm	1.0	1.6/2.4	1.6/2.4
Weight, with cables, kg	5.0	6.5	7.5

Ordering information

Welding head PRH 3-12	0444 300 880
Welding head PRH 3-38	0444 301 880
Welding head PRH 6-76	0444 302 880
Cartridges and collets are available for all diameters within the working range for each tool. Standard sizes, see page 64	

Orbital TIG welding

Welding heads orbital TIG



A22 POC

The POC 12-60 is a welding head for tube-to-tube sheet TIG welding. It is a precision-built, robust and versatile welding head which can be used for all types of tube-to-tube-sheet welding. The POC has a working range of 12 to 60 (93) mm outer tube diameter. The centering accuracy of the POC is very high and centering mandrels are available for inner tube diameters from 10.0 mm.

POC can be used together with the Aristo™ MechTig power sources.

Delivery includes

8 m of connection cable (current, gas, water).

POC

Orbital speed, rpm	0.2-4.4
Working range, electrode parallel to tube axis, mm	12-60
Working range, electrode at 30° from tube axis, mm	12-36 (93)
Filler wire diameter, mm	0.8-0.9
Filler wire speed, mm/s	0.15-1.5
Max spool dimension/weight, Ø mm/kg	100/0.5
Weight, less cables, kg	4.8

Ordering information

POC 12-60 welding head

0443 930 880

Orbital TIG welding

A25 modular components



A25

A25 is a modular component system – the key to TIG welding mechanisation. The modular components can easily be put together to create a system to suit your requirements. The TIG-narrow gap method can also be used together with the A25 system. Narrow gap with an extremely small joint angle and subsequent low joint volume.

The A25 modular system is used together with the Aristo™ MechTig power sources.

Ordering information

A25 welding automat with AVC and weaving slides, wire feed unit, VEC motor with turntable and BTE 250M torch mounted on a stand	0443 910 880
A25 welding automat with AVC and weaving slides, wire feed unit, VEC motor with turntable and BTE 500M torch mounted on a stand	0443 910 881
A25 welding automat with AVC and BTE 250M torch	0443 911 880
A25 welding automat with AVC and BTE 500M torch	0443 911 881
A25 welding automat with AVC and weaving slides, BTE 250M torch	0443 911 882
A25 welding automat with AVC and weaving slides, BTE 500M torch	0443 911 883
A25 welding automat with AVC and manual horizontal slide, BTE 250M torch	0443 911 884
A25 welding automat with AVC and manual horizontal slide, BTE 500M torch	0443 911 885
A25 welding automat with manual vertical and horizontal slide, BTE 250M torch	0443 911 886
A25 welding automat with manual vertical and horizontal slide, BTE 500 M torch	0443 911 887
A25 welding automat with slides for floating head, BTE 250M torch	0443 912 880
A25 welding automat with slides for floating head, BTE 500M torch	0443 912 881
Railbound carriage with a 2 m track for fitting A25 welding heads	0458 002 880
PAL 3 connection box for external motor regulator	0457 870 880

A25

AVC slide amplitude, mm	76
AVC slide speed, mm/s	2.81
Weaving slide amplitude, mm	76
Weaving slide speed, mm/s	19
Manual slide amplitude, mm	93
Floating slide amplitude, mm	76
Wire diameter, mm	0.6-1.6
Wire feed, m/min	0.1-2.6
Motor VEC with encoder, speed, rpm	1000
Motor VEC with encoder, ratio	672:1

A25 welding heads	Arc voltage control	Weaving	Manual cross slide	Manual vertical slide	Floating slide	Circular slide	Wire feeder	BTE 250 torch
STA 250
STA 500	.					.	.	
STA 250
STA 500	
STA 250
STA 500	
STA 250		
STA 500			
STB 250				
STB 500					.	.	.	

Wire capacity as standard STA/STB 250 0.6-1.2 mm, STA/STB 500 0.6-0.8, 1.2-1.6 mm
Accessories see page 65.

Orbital TIG welding

Accessories

Standard racks for PRD 100

A specific size of rack is used for each pipe diameter. The standard racks are listed under ordering information. Individual requirements relating to racks for other diameters can be supplied to order within the working range of the PRD welding head.

Ordering information

Outer diameter of the pipe:

114.30 mm - 4 inch	0333 400 880
141.30 mm - 5 inch	0333 400 881
168.27 mm - 6 inch	0333 400 882
219.07 mm - 8 inch	0333 400 883
273.05 mm - 10 inch	0333 400 884
323.85 mm - 12 inch	0333 400 885
355.60 mm - 14 inch	0333 400 886
406.40 mm - 16 inch	0333 400 887
457.20 mm - 18 inch	0333 400 888
508.00 mm - 20 inch	0333 400 889
558.80 mm - 22 inch	0333 400 890
609.60 mm - 24 inch	0333 400 891
660.00 mm - 26 inch	0333 400 892
711.00 mm - 28 inch	0333 400 893
762.00 mm - 30 inch	0333 400 894
813.00 mm - 32 inch	0333 400 895

864.00 mm - 34 inch	0333 400 896
914.00 mm - 36 inch	0333 400 897
Straight rack with suction feet, 2 m	0334 150 880
Straight rack with suction feet, 4 m	0334 150 881
Suction pump for rack	0334 504 001
Locking screw for standard racks together with feet 0333 402 880	0212 204 306
Locking screw for standard racks together with feet 0333 402 882-885	0190 507 451
Locking screw for standard racks together with feet 0333 402 886-890	0212 204 352

Feet for standard racks with tube diameters minus

4 mm	0333 402 881
8 mm	0333 402 882
12 mm	0333 402 883
16 mm	0333 402 884
20 mm	0333 402 885
24 mm	0333 402 886
28 mm	0333 402 887
32 mm	0333 402 888
36 mm	0333 402 889
40 mm	0333 402 890

Standard racks for PRD 160

Ordering information

Outer diameter of the pipe:

161-177 mm	0444 063 880
185-201 mm	0444 063 881
209-225 mm	0444 063 882
225-241 mm	0444 063 883
249-265 mm	0444 063 884
265-281 mm	0444 063 885
289-305 mm	0444 063 886
313-329 mm	0444 063 887
329-345 mm	0444 063 888
345-361 mm	0444 063 889
361-377 mm	0444 063 890
385-401 mm	0444 063 891
401-417 mm	0444 063 892
425-441 mm	0444 063 893
449-465 mm	0444 063 894
473-489 mm	0444 063 895
497-513 mm	0444 063 896
513-529 mm	0444 063 897
537-553 mm	0444 063 898
553-569 mm	0444 063 899

577-593 mm	0444 063 900
601-617 mm	0444 063 901
625-641 mm	0444 063 902
649-665 mm	0444 063 903
665-681 mm	0444 063 904
689-705 mm	0444 063 905
705-721 mm	0444 063 906
729-745 mm	0444 063 907
753-769 mm	0444 063 908
777-793 mm	0444 063 909
801-817 mm	0444 063 910
817-833 mm	0444 063 911
841-857 mm	0444 063 912
857-873 mm	0444 063 913
881-897 mm	0444 063 914
905-921 mm	0444 063 915
929-945 mm	0444 063 916
953-969 mm	0444 063 917
969-985 mm	0444 063 918
993-1009 mm	0444 063 919
1009-1025 mm	0444 063 920

Other diameters are available upon request.

Orbital TIG welding

Accessories

Collets and cartridges

Ordering information

PRH 3-12

Cartridges

Cartridge C	0444 310 880
Cartridge MF 6.0 mm	0444 310 881
Cartridge MF 6.35 mm	0444 310 882
Cartridge MF 8.0 mm	0444 310 883
Cartridge MF 9.53 mm	0444 310 884
Cartridge MF 10.0 mm	0444 310 885
Cartridge MF 12.0 mm	0444 310 886
Cartridge MF 12.70 mm	0444 310 887

Collets for Cartridge C, one set, four halves

Collets C blanks	0444 311 001
Collets C 6.0 mm	0444 311 002
Collets C 6.35 mm	0444 311 003
Collets C 8.0 mm	0444 311 004
Collets C 9.53 mm	0444 311 005
Collets C 10.0 mm	0444 311 006
Collets C 12.0 mm	0444 311 007
Collets C 12.70 mm	0444 311 008

PRH 3-38

Collets, one set, four halves

Collets PRH 3-38, blanks	0444 312 001
Collets PRH 3-38 6.0 mm	0444 312 002
Collets PRH 3-38 6.35 mm	0444 312 003
Collets PRH 3-38 8.0 mm	0444 312 004
Collets PRH 3-38 9.53 mm	0444 312 005
Collets PRH 3-38 10.0 mm	0444 312 006
Collets PRH 3-38 12.0 mm	0444 312 007
Collets PRH 3-38 12.70 mm	0444 312 008
Collets PRH 3-38 13.50 mm	0444 312 009
Collets PRH 3-38 15.0 mm	0444 312 024
Collets PRH 3-38 17.20 mm	0444 312 010
Collets PRH 3-38 18.0 mm	0444 312 011
Collets PRH 3-38 19.05 mm	0444 312 012
Collets PRH 3-38 21.30 mm	0444 312 013
Collets PRH 3-38 22.0 mm	0444 312 014
Collets PRH 3-38 25.40 mm	0444 312 015
Collets PRH 3-38 26.90 mm	0444 312 016
Collets PRH 3-38 28.0 mm	0444 312 017
Collets PRH 3-38 29.0 mm	0444 312 018
Collets PRH 3-38 31.80 mm	0444 312 019
Collets PRH 3-38 33.70 mm	0444 312 020
Collets PRH 3-38 34.0 mm	0444 312 021
Collets PRH 3-38 35.0 mm	0444 312 022
Collets PRH 3-38 38.10 mm	0444 312 023

PRH 6-76

Collets, one set, four halves

Collets PRH 6-76 blanks	0444 313 001
Collets PRH 6-76 6.0 mm	0444 313 002
Collets PRH 6-76 6.35 mm	0444 313 003
Collets PRH 6-76 8.0 mm	0444 313 004
Collets PRH 6-76 9.53 mm	0444 313 005
Collets PRH 6-76 10.0 mm	0444 313 006
Collets PRH 6-76 12.0 mm	0444 313 007
Collets PRH 6-76 12.70 mm	0444 313 008
Collets PRH 6-76 13.50 mm	0444 313 009
Collets PRH 6-76 16.0 mm	0444 313 038
Collets PRH 6-76 17.20 mm	0444 313 010
Collets PRH 6-76 18.0 mm	0444 313 011
Collets PRH 6-76 19.05 mm	0444 313 012
Collets PRH 6-76 20.0 mm	0444 313 042
Collets PRH 6-76 21.30 mm	0444 313 013
Collets PRH 6-76 22.0 mm	0444 313 014
Collets PRH 6-76 25.0 mm	0444 313 039
Collets PRH 6-76 25.40 mm	0444 313 015
Collets PRH 6-76 26.40 mm	0444 313 041
Collets PRH 6-76 26.90 mm	0444 313 016
Collets PRH 6-76 28.0 mm	0444 313 017
Collets PRH 6-76 29.0 mm	0444 313 018
Collets PRH 6-76 31.80 mm	0444 313 019
Collets PRH 6-76 33.70 mm	0444 313 020
Collets PRH 6-76 34.0 mm	0444 313 021
Collets PRH 6-76 35.0 mm	0444 313 022
Collets PRH 6-76 38.10 mm	0444 313 023
Collets PRH 6-76 40.0 mm	0444 313 024
Collets PRH 6-76 41.0 mm	0444 313 025
Collets PRH 6-76 42.40 mm	0444 313 026
Collets PRH 6-76 48.30 mm	0444 313 027
Collets PRH 6-76 50.80 mm	0444 313 028
Collets PRH 6-76 51.0 mm	0444 313 040
Collets PRH 6-76 52.0 mm	0444 313 029
Collets PRH 6-76 53.0 mm	0444 313 030
Collets PRH 6-76 54.0 mm	0444 313 037
Collets PRH 6-76 60.3 mm	0444 313 031
Collets PRH 6-76 63.0 mm	0444 313 036
Collets PRH 6-76 63.50 mm	0444 313 032
Collets PRH 6-76 70.0 mm	0444 313 033
Collets PRH 6-76 76.10 mm	0444 313 034
Collets PRH 6-76 76.20 mm	0444 313 035

Orbital TIG welding

Accessories

A25 components and accessories

Ordering information

Bracket	0441 404 880	Bracket	0441 412 880
Wire feed unit, incl feed roller, 0.6-0.8 mm	0441 300 882	Brake hub	0146 967 881
Feed roller 1.0 - 1.2 mm	0369 557 003	Bobbin protection	0157 482 880
Feed roller 1.2 - 1.6 mm	0369 557 007	Motor VEC with tacho, speed 1000 rpm, ratio 672:1	0457 258 880
Outlet pipe 0.8 - 1.2 mm	0441 456 881	Control unit to VEC	0457 222 880
Outlet pipe 1.6 mm	0441 456 882	Turntable with return cable connection for VEC motor	0442 712 880
Connection cable, feed unit 10 m	0456 904 880	Narrow Gap kit for BTE 500M	0441 667 880
Wire hose, per metre (std 400 mm)	0192 799 112	Motor control unit PAL 3	0457 870 990
Wire nozzle, BTE 250M	0441 407 880		
Wire nozzle, BTE 500M	0441 407 881		
TIG torch BTE 250M	0444 295 880		
TIG torch BTE 500M	0444 296 880		
Holder BTE 250M	0441 414 880		
Holder BTE 500M	0441 414 881		
Slide AVC	0443 913 880		
Circular slide	0145 945 880		
Slide manual	0413 518 880		
Slide weaving	0443 913 881		
Slide floating	0441 674 881		
Single guide wheel unit, BTE 250M	0441 833 880		
Single guide wheel unit, BTE 500M	0441 833 881		

POC shafts and centering mandrels

Ordering information

Shaft type A	0332 207 880	Centering mandrel Ø 26.5 - 29.0 mm	0444 542 882
Centering mandrel Ø 10.0 - 10.5 mm	0444 540 880	Centering mandrel Ø 28.5 - 31.0 mm	0444 542 883
Centering mandrel Ø 10.5 - 11.0 mm	0444 540 881	Centering mandrel Ø 30.5 - 33.0 mm	0444 542 884
Centering mandrel Ø 11.0 - 11.5 mm	0444 540 882	Centering mandrel Ø 32.5 - 36.0 mm	0444 542 885
Centering mandrel Ø 11.5 - 12.0 mm	0444 540 883	Centering mandrel Ø 35.5 - 39.0 mm	0444 542 886
Centering mandrel Ø 12.0 - 12.5 mm	0444 540 884	Centering mandrel Ø 38.5 - 42.0 mm	0444 542 887
Centering mandrel Ø 12.5 - 13.0 mm	0444 540 885	Shaft type D	0332 210 880
Shaft type B	0332 208 880	Centering mandrel Ø 41.5 - 45.0 mm	0444 543 880
Centering mandrel Ø 12.8 - 14.0 mm	0444 541 880	Centering mandrel Ø 44.5 - 48.0 mm	0444 543 881
Centering mandrel Ø 13.8 - 15.0 mm	0444 541 881	Centering mandrel Ø 47.5 - 51.0 mm	0444 543 882
Centering mandrel Ø 14.8 - 16.0 mm	0444 541 882	Centering mandrel Ø 50.5 - 54.0 mm	0444 543 883
Centering mandrel Ø 15.8 - 17.0 mm	0444 541 883	Centering mandrel Ø 53.5 - 58.0 mm	0444 543 884
Centering mandrel Ø 16.8 - 18.0 mm	0444 541 884	Centering mandrel Ø 57.5 - 62.0 mm	0444 543 885
Centering mandrel Ø 17.8 - 19.0 mm	0444 541 885	Centering mandrel Ø 61.5 - 66.0 mm	0444 543 886
Centering mandrel Ø 18.8 - 20.5 mm	0444 541 886	Centering mandrel Ø 65.5 - 70.0 mm	0444 543 887
Centering mandrel Ø 19.8 - 22.5 mm	0444 541 887	Centering mandrel Ø 69.5 - 74.0 mm	0444 543 888
Shaft type C	0332 209 880	Centering mandrel Ø 73.5 - 78.0 mm	0444 543 889
Centering mandrel Ø 22.0 - 25.0 mm	0444 542 880	Centering mandrel Ø 77.5 - 82.0 mm	0444 543 890
Centering mandrel Ø 24.5 - 27.0 mm	0444 542 881		

POC 12-60 accessories

Ordering information

Counterbalancing block	0332 330 005
Three-point support complete with electrode holder. To be used for fillet weld up to Ø 36 mm	0333 897 880
Three-point support complete with electrode holder. To be used for fillet weld from Ø 36 mm to Ø 93 mm	0333 897 883
Front casting, titanium	0441 000 880
Internal bore welding torch 9.5-15	0441 131 880
Internal bore welding torch 15-20	0441 132 880
Internal bore welding torch 20-30	0441 133 880

Orbital TIG welding

Accessories



Angular support

The angular support is used to adjust the electrode angle in the joint. The support is available for PRB/PRC 17-49, 33-90 and 60-170.

Ordering information

Angular support

0443 875 880



Narrow Gap head for PRD

ESAB have developed equipment for Narrow Gap welding together with the PRD welding head. The TIG Narrow Gap Orbital Welding has an extremely narrow groove with a subsequent small joint volume. Welding in all positions is possible. Stainless and carbon steel can be welded.

Ordering information

Narrow Gap head 50 mm, PRD 100

0441 623 880

Narrow Gap head 80 mm, PRD 100

0441 623 881

Narrow Gap head 50 mm, PRD 160

0444 339 880

Wire straightener Ø 0.8 mm

0441 355 882

Wire straightener Ø 1.0 mm

0441 355 881

Wire straightener Ø 1.2 mm

0441 355 880



Balancing block

The balancing block is capable of carrying welding heads, drilling and grinding machines weighing 5.5-9 kg. The wire can be extended to a maximum length of 2.7 metre. The spring force is constant, i.e. the wire has the same lifting capacity irrespective of the length to which it has been extended.

Ordering information

Balancing block

0332 330 005



Remote control MechT 1 CAN

MechT 1 CAN is a small remote control that is easy to use and can control most of the parameters on Aristo™ MechControl 2 and 4 and Aristo™ MechTig C2002i. The cable between the control unit and remote control is available in different lengths.

Ordering information

Remote control MechT 1 CAN

0460 181 880

Cable, length 5 m

0459 554 880

Cable, length 10 m

0459 554 881

Cable, length 15 m

0459 554 882

Cable, length 25 m

0459 554 883

Cable, length 0.25 m

0459 554 884

Orbital TIG welding

Ancillary equipment



MEI 21 wire feed unit

The MEI 21 is a wire feed unit with four wheel drive for orbital TIG welding. A separate wire feed unit is a great advantage since it eliminates the need for a wire feed unit and wire spool mounted on the welding head. 5 kg wire spools can be used. The MEI 21 can be used for wire dimensions from 0.6 mm to 0.8 mm and can be used together with the Aristo™ MechTig power sources.

Delivery includes

The MEI 21 wire feed unit is delivered with a wire hose.

	MEI 21
Wire diameter, mm	0.6-0.8
Wire feed, m/min	0.1-2.6
Max spool dimension/weight, Ø mm/kg	200/5
Hub width, mm	60
Hub hole diameter, mm	51.5
Wire guide length, m	4.2
Weight, kg	4

Ordering information

MEI 21 0443 830 880

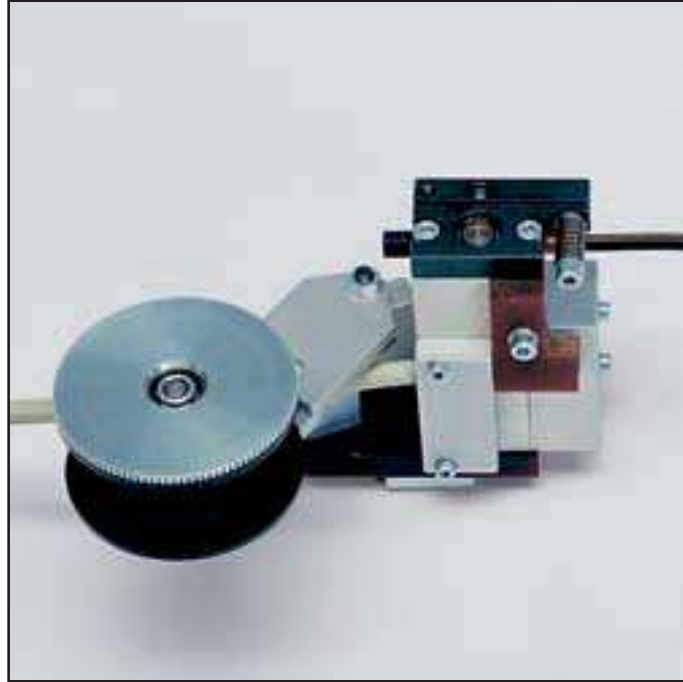

MEI 10 wire feed unit

The MEI 10 is a wire feed unit developed for mounting on PRB 17-170 tools (PRC17-49 only with AVC). MEI 10 and the PRB/PRC tools can be used together with the Aristo™ MechTig power sources.

The compact design of the wire feed unit keeps the increase in the size of the tool when the unit is mounted to a minimum. Thanks to the very short distance the wire needs to be fed, from the reel to the molten pool, the MEI 10 is ideal for aluminium welding. It is naturally also possible to use the wire-feed unit for mild and stainless steel welding.

The MEI 10 weighs only 0.5 kg (without reel and cable) and it can be used for wire dimensions of 0.8 mm to 1.0 mm for aluminium and 0.8 mm for steel. A geared DC motor drives the feed roller via gear wheels. The motor is equipped with a pulse generator which enables the precise adjustment of the wire feed speed.

	MEI 10
Wire diameter, mm	0.8 (steel)
Wire feed, m/min	0.1-1.2
Max spool dimension/weight, Ø mm/kg	60/0.26
Hub width, mm	-
Hub hole diameter, mm	-
Wire guide length, m	0.1
Weight, excl bobbin, kg	0.5

Ordering information

MEI 10 for PRB 17-49 & PRC 17-49 with AVC 0444 211 880
 MEI 10 for PRB 33-90, PRC 33-90 with AVC & PRC with AVC and weaving 0444 212 880
 MEI 10 for PRB 60-170, PRC 60-170 with AVC & PRC 60-170 with AVC and weaving 0444 213 880
 Bobbin (empty) 0444 192 001

Orbital TIG welding

Power sources



Aristo™ MechTig C2002i

Aristo™ MechTig C2002i is a small and compact orbital welding power source with integrated water cooler which together with the excellent tube welding heads provides high quality and productivity. The machine is equipped with a 10 inch colour monitor and the interface is windows like. For control of the welding settings you can either use a graphical interface to control all necessary parameters or a spread sheet where you can see all parameters. The Aristo™ MechTig C2002i is delivered with a ready library where you can find a number of pre-defined programs that you can use for fast and easy set-up. There is also a function for auto generation of programs. This function creates a start program, you only need to key in some basic parameters as material, outer diameter and the thickness of the pipe. The welding program can then be stored in the program library. Aristo™ MechTig C2002i can be used together with the welding heads PRB, PRD 160 with wire feed unit, PRH, POC, wire feed units MEI 10, MEI 21 and A25 component system with manual floating slides.



Aristo™ MechTig C2002i

Mains supply, V/Hz	230/1 50/60
Setting range TIG, A	4-200
Open circuit voltage, V	71-78
Fuse (slow), A	20
Max output at 35% duty cycle, A/V	180 / 17
Max output at 60% duty cycle, A/V	140 / 15.5
Max output at 100% duty cycle, A/V	110 / 14.5
External dimensions, LxWxH	470x479x472
Weight, kg	30

Ordering information

Aristo™ MechTig C2002i 0444 600 880

Accessories:

MechT 1 CAN 0460 181 880

Trolley, see page 44 0301 100 880

Orbital TIG welding

Power sources orbital TIG



Aristo™ MechControl 2 and 4

Aristo™ MechControl 2 and 4 are small and compact orbital welding control boxes that together with a MechTig power source will provide high quality and productivity together with the excellent tube welding heads.

The machine is equipped with a 10 inch colour monitor and the interface is windows like. For control of the welding settings you can either use a graphical interface to control all necessary parameters or a spread sheet where you can see all parameters. The Aristo™ MechControl 2 and 4 are delivered with a ready library where you can find a number of pre-defined programs that you can use for fast and easy set-up. There is also a function for auto generation of programs. This function creates a start program, you only need to key in some basic parameters as material, outer diameter and the thickness of the pipe. The welding program can then be stored in the program library.

Aristo™ MechControl 2 can use the same tools as Aristo™ MechTig C2002i, i.e. welding heads PRB, PRD 160 with wire feed unit, PRH, POC, wire feed units MEI 10, MEI 21 and A25 component system with manual/floating slides.

Aristo™ MechControl 4 can use all the tools in our program.

Aristo™ MechControl 2 and 4

Mains supply, V/Hz	230/1, 50/60
External dimensions, LxWxH	471x403x364
Weight, kg	17.4 (MechControl 2)
Weight, kg	18.4 (MechControl 4)

Ordering information

Aristo™ MechControl 2	0444 500 880
Aristo™ MechControl 4	0444 500 881
Connection cable 1.7 m	0460 210 880
Connection cable 8.0 m	0460 210 881
Remote control MechT 1 CAN	0460 181 880
Cable between MechControl 2 or 4 and MechT 1 CAN:	
Length 5 m	0459 554 880
Length 10 m	0459 554 881
Length 15 m	0459 554 882
Length 25 m	0459 554 883
Length 0.25 m	0459 554 884

Aristo™ MechTig 4000iw

The Aristo™ MechTig 4000iw is designed to work together with the Aristo™ MechControl 2 and 4. The power source is compact and sturdy and based on inverter technology that provides reliable equipment with outstanding welding characteristics.

Connection cables up to 8 meters provides a working range of up to 16 meters to suit all your individual welding needs.

Aristo™ MechTig 4000iw

Mains supply, V/Hz	3x400, 50/60
Setting range TIG DC, A	4-400
Open circuit voltage, V	78-90
Fuse (slow), A	16
Max output at 35% duty cycle, A / V	400 / 26
Max output at 60% duty cycle, A / V	320 / 23
Max output at 100% duty cycle, A / V	250 / 20
Power factor at maximum current	0.75
Efficiency at maximum current, %	97.1
External dimensions (with cooling unit), LxWxH	625x394x776
Weight, kg	81

Ordering information

Aristo™ MechTig 4000iw	0458 625 886
Multi voltage unit, wide body	0459 145 880
Handles incl mounting screws for Multi voltage unit (compl set = 2)	0459 307 881
Trolley, see page 44	0458 530 880
Guide pin (if no trolley)	0458 731 880
Connection cable, 1.7 m	0460 210 880
Connection cable, 8.0 m	0460 210 881

Welding automation

Universal mechanisation equipment



Railtrac 1000

Railtrac 1000 is a series of programmable and portable equipment for mechanising welding and cutting. Different solutions often provide the answer to monotonous, gruelling work and produce higher productivity and more consistent quality at the same time. Railtrac is specially designed for MIG/MAG and TIG welding and thermal cutting.

Railtrac is made up of robust components and is available in the following four basic models. All the models have five different programs, including interval welding. The rail can be fixed in place using suction cups of the ejector type, screw attachments or permanent magnets.

- Railtrac F1000, Flexi, the least complex equipment for welding or cutting along a combi-rail, either flexible or stiffened.
- Railtrac FW1000, Flexi Weaver, the Flexi system plus a remote-control unit and a weaving device which makes it possible to weave the arc according to different patterns.
- Railtrac FR1000, Flexi Return, has the combi-rail. It also has movable start and stop indicators for automatic operation.
- Railtrac FWR1000, Flexi Weaver Return, also has the flexible combi-rail, a remote-control unit, a weaving device and start and stop indicators for automatic operation.

Using the remote control, it is possible to select:

- Start and stop
- Travel or welding direction/cutting direction
- Travel or welding speed/cutting speed
- Weaving width
- Zero-line displacement
- Rapid speed on/off
- Backfill function
- Potentiometer control of welding parameters

Railtrac 1000

Rail length, m	2.5
Rail bending radius, min, mm	1000/3000
Welding speed, m/min	0.10-1.5
Weaving range, mm	1-30
Weaving speed, mm/s	6-60
Dwell time, s	0.0-9.9

Welding automation

Universal mechanisation equipment

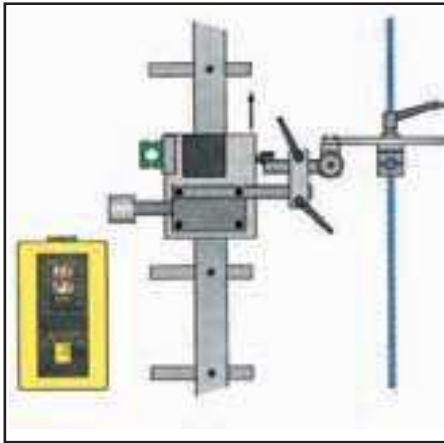

Railtrac F1000

Railtrac F1000, Flexi, for welding and thermal cutting.

- Welds and cuts in all positions on magnetic and non-magnetic materials
- Quick assembly and easy operation
- Programmable with five programs
- Calibrated setting values in cm, mm and sec
- Programmable "backfill" for crater filling
- Self-instructive programming manual
- Stiff or flexible, robust rail made of standard aluminium profiles without racks
- Track which can be extended or cut to required length
- Angled attachment for quick adjustment of pistol angle (option)
- "Floating" head for mechanical height maintenance (option)

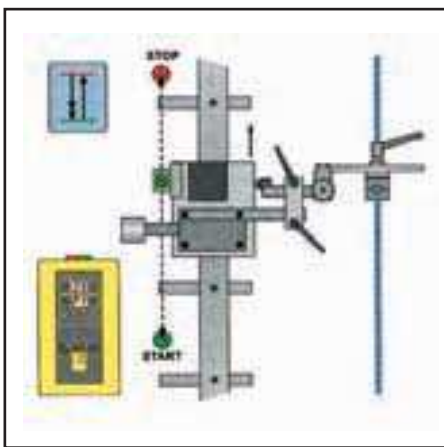

Railtrac FR1000

Railtrac FR1000, Flexi Return, for welding and cutting with automatic return.

- Welds and cuts in all positions on magnetic and non-magnetic materials
- Quick set-up and easy operation
- Programmable with five programs
- Calibrated setting values in mm, cm and sec
- Programmable "backfill" for crater filling
- Self-instructive programming manual
- Stiff or flexible rail made of standard aluminium profiles without racks
- Rail which can be extended bent or cut
- Angle bracket for quick adjustment of torch angle (option)
- "Floating" head for mechanical height maintenance (option)

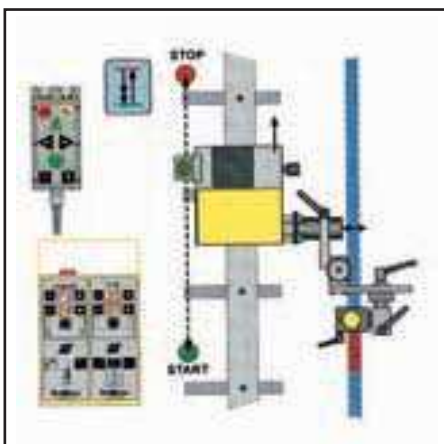

Railtrac FWR1000

Railtrac FWR1000, Flexi Weaver Return, for oscillated welding with automatic return.

- Welds in all positions on magnetic and non-magnetic materials
- Quick set-up and easy operation
- Programmable with five programs
- Calibrated setting values in mm, cm and sec
- Programmable "backfill" for crater filling
- Self-instructive programming manual
- Flexible rail made of standard aluminium profiles without racks
- Rail which can be extended or cut to required length
- Angle bracket for quick adjustment of torch angle (option)
- Tilttable weaving unit for fillet welds (option)
- Turnable weaving unit for horizontal weaving in sloping joints (option)
- "Floating" head for mechanical height maintenance (option)
- Potentiometers in the remote control for parameter adjustments

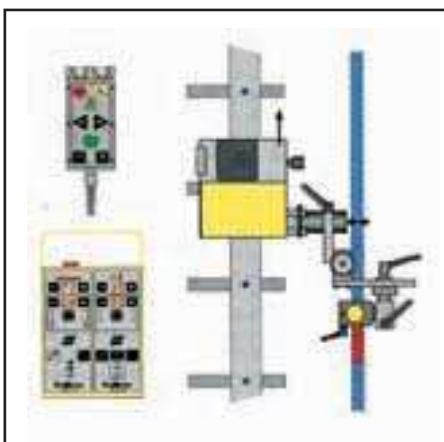

Railtrac FW1000/FW1000 L

Railtrac FW1000, Flexi Weaver, for oscillated welding. The Railtrac FW1000 can be delivered in a "FW1000 L" version if the welding process need to be done with a lower welding speed than with FW1000.

- Welds and cuts in all positions on magnetic and non-magnetic materials
- Quick set-up and easy operation
- Programmable with five programs
- Calibrated setting values in cm, mm and sec
- Self-instructive programming manual
- Resilient remote control with profiled membrane buttons
- Stiff or flexible rail made of standard aluminium profiles without racks
- Rail which can be extended or cut to required length
- Angle bracket for quick adjustment of torch angle (option)
- Tilttable weaving unit for fillet welds (option)
- Turnable weaving unit for horizontal weaving in sloping joints (option)
- "Floating" head for mechanical height maintenance (option)
- Potentiometers in the remote control for parameter adjustments

Welding automation

Tractor automats



Railtrac BV1000/BVR1000

Railtrac BV1000 and BVR1000 are two automatic units for mechanising the repair and hardfacing of rail profiles smoothly and efficiently. The equipment can be assembled, programmed and controlled quickly and easily by one person. Learning to use it is easy and handling is extremely fast.

The system comprises two rail fasteners, a stable aluminium profile, a carriage with a weaving unit, control electronics and remote control. The weaving unit and control electronics are fully synchronised to enable a number of weaving patterns to be pre-programmed.

The weaving movements start from a laterally adjustable zero line, either the outer side or the inner side of the rail. This zero line can also be moved laterally during welding. Different speeds can be used in each program to produce the most consistent weld metal thickness possible.

The remote control unit enables the welder to have full control of all the movements of the machine without lifting his/her welding visor.

Railtrac BV1000, with a weaving device and four different programs.

Railtrac BVR1000, with a weaving device, start and stop indicators, return function for automatic operation and six different programs.

Railtrac BV/BVR

Rail length, m	2
Welding speed, m/min	0.1-1.5
Weaving range, mm	1-80
Weaving speed, mm/s	7-50
Max power consumption, W	80
Control voltage, V, AC	36-46
Crater fill duration, s	0-9.9
Zero-line shift, mm	25 (±12.5)
Programmable edge length, cm	6-99
Weight, kg	7



Tramtrac™ II

Tramtrac™ II is a light weight tractor for repairing worn city tram rails. It has a wire feed unit and controls for travel speed, wire feed speed, inching and start/stop of the welding process.

The best way to get most out of your Tramtrac™ II is to use it together with either OK Tubrodur 14.71 or OK Tubrodur 15.65. Both are self shielded wires needing no shielding gas and the best power source to use is the Origo™ Mig 410.

Tramtrac™ II

Welding speed, m/min	0.3-1.1
Control voltage, V, AC	36-46
Power, W	90
External dimensions, LxWxH	600x300x150
Weight, without consumables, kg	12

Ordering information

Tramtrac™ II	0814 721 880
Connection cable 10 m	0457 360 884
Accessories:	
Magnetic earth clamp	0000 500 415

Welding automation

Tractor automats



Frametrac™

The Frametrac™ is a superb alternative when you wish to automate your frame welding. It is built for use together with ESAB's semi-automatic power sources and feed units.

The Frametrac™ is a compact, motor powered tractor that travels on the door frame to be welded. The four driving wheels guarantee an even, stable movement on the frame.

A standard ESAB torch can be mounted in the torch attachment and can be adjusted to fit your frame and type of welding.

From the control box and from the remote control you can control travel direction and speed, weaving speed and width. To secure best possible arc stability, Frametrac™ is equipped with an automatic current control, ACC, that holds the arc length stable.



Frametrac™	
Welding speed, m/min	1.0-9.9
Control voltage, V, AC	36-46
Power, W	80
External dimensions, LxWxH	280x430x508
Weight, without consumables, kg	30

Ordering information

Frametrac with ACC	0449 925 880
Spring arms for frames 50-75 mm	0449 904 025
Connection cable (2 pcs needed)	0457 360 880

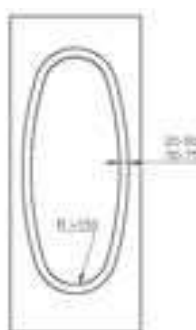

Frame 1
On this type of frame, the Frametrac can be used directly.

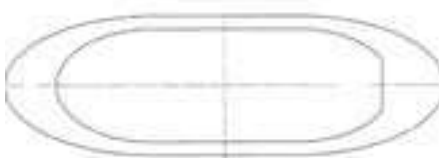

Frame 2
On this type of frame, a template is needed.

Welding automation

Tractor automats



Miggytrac 1001

The Miggytrac 1001 is a small and compact, motor-powered tractor to which a standard ESAB welding torch can be quickly attached.

The four driving wheels, together with the magnet which is fitted on the tractor, guarantee even, stable movement. The magnet holds the tractor in the correct position on the workpiece, even if it is bent or angled. The tractor functions as a straightforward remote control for the feed unit; you decide on the travel direction and then start and stop welding from the panel. The panel features additional functions such as travel speed settings, wire feed, voltage and welding on/off. The tractor follows the joint using guide wheels.

Miggytrac 1001

Welding speed, m/min	0.15-1.2
Control voltage, V, AC	36-46
Power, W	20
Weight, kg	7
External dimensions, LxWxH, mm	266x257x267

Ordering information

Miggytrac 1001	0457 357 881
Connection cable to wire feed unit	0457 360 880
Welding screen	0457 463 880
Universal connectors:	
Transformers 230/36 V	0457 467 880
Universal connection cable for other brands	0457 360 881



Miggytrac 2000

The Miggytrac 2000 is a small, compact, motor-operated trolley that is designed for the mechanisation of GMAW, gas metal arc welding, in particular. Just fix the torch in the holder and Miggytrac 2000 will take over the welding procedure. The permanent built-in magnet, which can be switched on/off, holds the tractor in the correct position on the workpiece. The lightweight trolley has four-wheel drive to ensure smooth and steady welding travel.

The Miggytrac 2000 has a digital display to permit simple programming. It is very easy to move the trolley from one welding task to the next.

Miggytrac 2000

Travel speed, m/min	2.5
Welding speed, m/min	0.15-1.5
Control voltage, V, AC	36-42
Max power consumption, W	25
Intermittent welding range, cm	1-99
Crater fill duration, s	0-9.9
Weight, kg	8.5
External dimensions, LxWxH, mm	400x340x370

Ordering information

Miggytrac 2000	0457 358 880
Connection cable to wire feed unit	0457 360 880
Welding screen	0457 463 880
Universal connectors:	
Transformers 230/36 V	0457 467 880
Universal connection cable for other brands	0457 360 881

Welding automation

Tractor automats



Miggytrac 3000

The Miggytrac 3000 is designed to be used together with ESAB's semi-automatic power sources.

The Miggytrac 3000 is a small, compact, motor-powered tractor with integrated wire feed and water-cooled welding torch, designed for horizontal MIG/MAG welding of plates and beams. Miggytrac 3000 is provided with four-wheel drive. The carriage follows the weld joint by means of one front and one rear guide wheel. The wheels are adjusted so as to make the carriage travel diagonally towards the flange or stiffener to be welded.

Miggytrac 3000

Travel speed, m/min	2.5
Welding speed, m/min	0.15-1.5
Control voltage, V, AC	36-46
Max power consumption, W	80
Intermittent welding range, cm	1-99
Crater fill duration, s	0-9.9
Weight, kg	17
External dimensions, LxWxH, mm	370x400-530x520

Ordering information

Miggytrac 3000, with straight water-cooled swan neck	0457 359 880
Contact tip 1.0 CO ₂	0468 502 005
Contact tip 1.2 CO ₂	0468 502 007
Contact tip 1.4 CO ₂	0468 502 008



A2 Tripletrac

The A2 Tripletrac is superb for internal circumferential welding of large cylindrical objects due to its clever design with a steering wheel. The tractor can be equipped with ESAB's A2-A6 Process Controller PEH or A2 Welding Controller PEI.

The A2 Tripletrac's three-wheeled tractor carriage steers with the front wheel. This, combined with the fact that the steering wheel also controls the horizontal slide, ensures easy control of the wire position. This makes the A2 Tripletrac ideal for internal circumferential welding of large cylindrical objects that are rotating on a roller bed, for example pressure vessels and wind towers. The compact, efficient design makes it easy to move the A2 Tripletrac from one place to another, such as between different welding workpieces. The carriage is equipped with a handle to disengage the gear, so the A2 Tripletrac can easily be pushed to another place.

Single SAW

Max load at 100% duty cycle, A	800
Wire feed max, m/min	0.2-9.0
Travel speed, m/min	0.1-1.7
External dimensions, LxWxH, mm	594x686x956
Weight, excl wire and flux, kg	47

Ordering information

A2 Tripletrac with process controller PEH	0449 430 880
A2 Tripletrac with process controller PEI	0449 430 881

Welding automation

Tractor automats



A2 Multitrac with A2/A6 process controller PEH

The A2 Multitrac with the A2/A6 process controller PEH is available for both the SAW and the GMAW method.

If the SAW-version is chosen, the A2 Multitrac is capable of working equally well with either single or twin wire.

The feed unit secures an even and stable wire-feed speed.

Accurate travel speed is ensured by means of four-wheel drive.

Exact presetting and control of the welding parameters is done on the instrument panel, which is equipped with a digital display.

The Multitrac is fully mobile and can easily be moved from one welding station to another. It can also be quickly set-up for different workpieces.

	Single SAW	Twin SAW	Single GMAW	Single GMAW with MTW 600
Wire Ø, unall. solid	1.6-4.0	2x1.2-2.5	0.8-1.6	0.8-1.6
Wire Ø, SS	1.6-4.0	2x1.2-2.5	0.8-1.6	0.8-1.6
Wire Ø, Al	-	-	1.2-1.6	1.0-2.0
Wire Ø, CW	1.6-4.0	-	1.2-2.4	1.2-2.4
Wire feed, m/min	0.2-9	0.2-9	0.2-16	2.0-25
Travel speed, m/min	0.1-1.7	0.1-1.7	0.1-1.7	0.1-1.7
External dimensions, LxWxH, mm	870x400 x830	870x400 x830	870x400 x830	870x400 x830
Weight, kg	47	47	43	43

Ordering information

A2 Multitrac with A2/A6 process controller PEH SAW/ single	0449 160 880
A2 Multitrac with A2/A6 process controller PEH SAW/ twin	0449 160 881
A2 Multitrac with A2/A6 process controller PEH GMAW	0449 161 880
A2 Multitrac with A2/A6 process controller PEH GMAW with MTW 600 welding torch	0449 161 881
Wear parts, see page 84-85	



A2 Multitrac with A2 process controller PEI

The A2 Multitrac with the process controller PEI is available for both the SAW and the GMAW method.

If the SAW-version is chosen, the A2 Multitrac is capable of working equally well with either single or twin wire.

The feed unit secures an even and stable wire-feed speed.

Accurate travel speed is ensured by means of four-wheel drive.

The control equipment is very easy to use with a minimum of training. The welding parameters are adjusted by turning knobs and the actual parameters are shown on the digital displays.

The Multitrac is fully mobile and can easily be moved from one welding station to another. It can also be quickly set-up for different workpieces.

	Single SAW	Twin SAW	GMAW
Max load at 100% duty cycle, A	800	800	600
Wire Ø, unall. solid	1.6-4.0	2x1.2-2.5	0.8-1.6
Wire Ø, SS	1.6-4.0	2x1.2-2.5	0.8-1.6
Wire Ø, Al	-	-	1.2-1.6
Wire Ø, CW	1.6-4.0	-	1.2-2.4
Wire feed, m/min	0.2-9	0.2-9	0.2-16
Travel speed, m/min	0.1-1.7	0.1-1.7	0.1-1.7
External dimensions, LxWxH, mm	870x400 x860	870x400 x860	870x400 x860
Weight, kg	47	47	43

Ordering information

A2 Multitrac with A2 process controller PEI SAW	0449 360 880
A2 Multitrac with A2 process controller PEI SAW Twin	0449 360 881
A2 Multitrac with A2 process controller PEI GMAW	0449 361 880
Wear parts, see page 84-85	

Welding automation

Tractor automats



A6 Mastertrac

The A6 Mastertrac is a heavily-dimensioned self-propelled, four-wheel drive, automatic welding machine. The advanced electronic control equipment provides high precision and the digital display enables all the welding parameters to be preset accurately – either beforehand or during welding. The A6 Mastertrac is easy to use and once it is running, it requires only the supervision of the operator. The automat can be supplied for SAW in single, twin or tandem version. Also available for GMAW.

	Single SAW	Single GMAW	Twin SAW	Tandem
Max load at 100% duty cycle, A	1500	600	1500	2x1500
Wire diameter, mm	3.0-6.0	1.0-3.2	2x2.0-3.0	2x3.0-6.0
Wire feed, m/min	0.2-4.0	0.8-16.6	0.2-4.0	0.2-4.0
Travel speed, m/min	0.1-2.0	0.1-2.0	0.1-2.0	0.1-2.0
External dimensions, LxWxH, mm	1410x750x850	1410x750x850	1410x750x850	1410x990x850
Weight, kg	110	100	110	158

Ordering information

A6 Single Mastertrac, standard	0449 260 880
A6 Twin Mastertrac, standard	0449 260 881
A6 Single Mastertrac, high speed	0449 260 890
A6 Twin Mastertrac, high speed	0449 260 891
A6 Tandem Mastertrac, complete	0334 191 882
Wear parts, see page 84-85	



A6-DK

The A6-DK welding machine has two welding heads. It is built up of components from the well-known A6 system. A6-DK is designed for simultaneously welding horizontal-vertical fillets on both sides of a web or through panels.

A6-DK straddles work pieces up to 800 mm high and with a symmetrical profile of 400 mm. A6-DK travels directly on the work piece and is guided along the joint with the aid of a guide unit attached to the contact unit. The travel speed is steplessly adjustable from 0.15 to 2.0 m/min.

	A6-DK SAW
Max load at 100% duty cycle, A	1500
Wire diameter, mm	3.0-6.0
Wire feed, m/min	0.2-4.0
Travel speed, m/min	0.15-2.0
External dimensions, LxWxH, mm	870x400x830
Vertical space limitation, mm	800
Longitudinal symmetrical extension, mm	400
Weight, kg	150

Ordering information

A6-DK SAW single wire excl. wire reel, feed rollers and contact jaws*	0454 200 901
Wire reel plastic 30 kg	0153 872 880
Wire reel steel 30 kg	0416 492 880
*When contact equipment is excluded feed rollers and contact jaws have to be ordered separately.	

Welding automation

Welding heads



A2 S Mini Master

The A2 S Mini Master represents an automatic welding system designed with the emphasis on low weight, compactness and flexible use. The system is built around basic units. The degree of automation and process orientation of the basic unit you choose can be expanded or modified as required, depending on the application. Appropriate welding heads can be combined with suitable manipulators, which results in a total solution to a specific welding problem.

	Single SAW	Twin SAW	Single GMAW
Max load at 100% duty cycle, A	1000	1000	600
Wire diameter, mm	1.6-4.0	2x1.2-2.5	0.8-2.4
Wire feed, m/min	0.2-9	0.2-9	0.2-16

Ordering information

For ordering information please contact your nearest ESAB representative
Wear parts, see page 84-85



A2 S GMAW Mini Master

The A2 S GMAW Mini Master is a compact MIG/MAG version of the A2 S SAW Mini Master welding head. The GMAW welding head is equipped with an MTW 600 welding torch, which is specially designed for use where an automatic MIG/MAG welding torch is required for heavy-duty use.

The very effective "whirlcool liquid cooling system" is integrated in both the contact tube and the outer jacket of the torch for maximum cooling effect. All connections are positioned in the upper end of the torch to facilitate the mounting of the necessary supply and to protect the connection from welding arc radiation.

	Single GMAW
Max load at 100% duty cycle, A - Mix/Ar	600
Max load at 100% duty cycle, A - CO ₂	650
Wire diameter, mm	1.0-2.4
Wire feed, m/min	2.0-25

Ordering information

For ordering information, please contact your nearest ESAB representative
Wear parts, see page 84-85

Welding automation

Welding heads

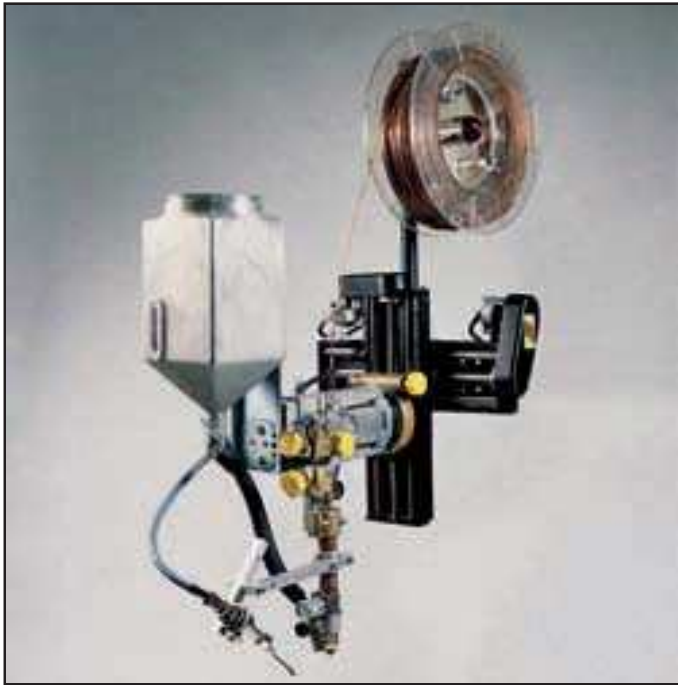

A6 S Arc Master

The A6S Arc Master is the complete system for heavy production welding offering flexibility, operational reliability and durability. It constitutes the base of ESAB's automatic welding program with an extensive modular and component system. It is available in a number of standard models and can be adapted to suit the customer's specific demands.

From an existing model, the A6 S can be rebuilt and extended to the required automation level, by means of positioning, joint tracking, flux handling and so on, as the requirements change.

The picture shows A6S Arc Master including options.

	Single SAW	Twin SAW	Single SAW	Twin SAW	Single GMAW
Max load at 100% duty cycle, A	1500	1500	1500	1500	600
Gear ratio	156:1	156:1	74:1	74:1	74:1
Wire diameter, mm	2.5-6.0	2x2.0-3.0	1.6-4.0	2x1.2-3.0	0.8-3.2
Wire feed, m/min	0.2-4.0	0.2-4.0	0.4-8.0	0.4-8.0	0.8-16.6

Ordering information

For ordering information, please contact your nearest ESAB representative
Wear parts, see page 84-85

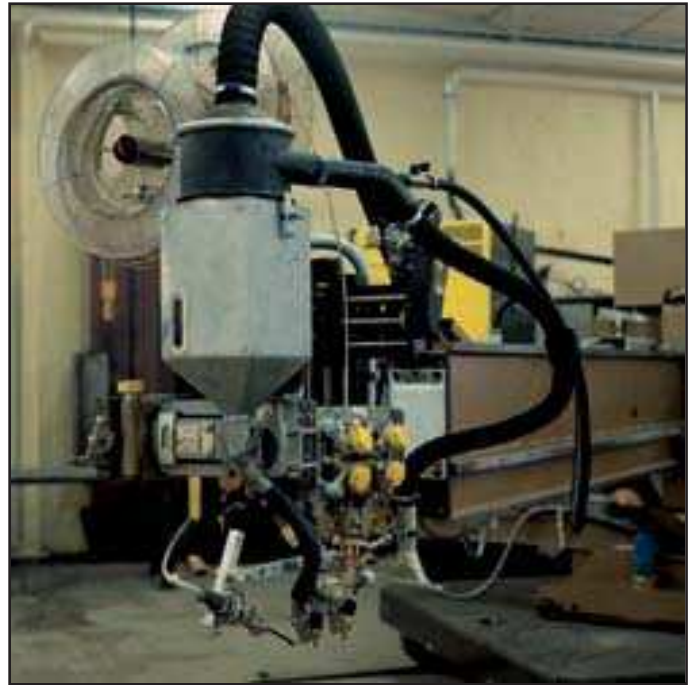

A6 S Tandem Master

The A6 S Tandem Master is a highly versatile welding automat equipped with two A6 heads – for either DC/DC or DC/AC welding.

Direct current provides good penetration, whereas alternating current secures a high deposition rate. The A6 S Tandem Master is available in a number of models to match the customer's safety, quality and productivity requirements.

A6 S Tandem Master	
Max load at 100% duty cycle, A	2x1500
Wire diameter, mm	2x3.0-6.0
Wire feed, m/min	0.2-4.0

Ordering information

A6 DS Tandem Master (gear ratio 156:1)	0809 939 880
A6 DS Tandem Master (gear ratio 74:1)	0809 939 881
A6 S Tandem Master (gear ratio 156:1)	0809 940 880
A6 S Tandem Master (gear ratio 74:1)	0809 940 881

Welding automation

Welding heads/Power sources

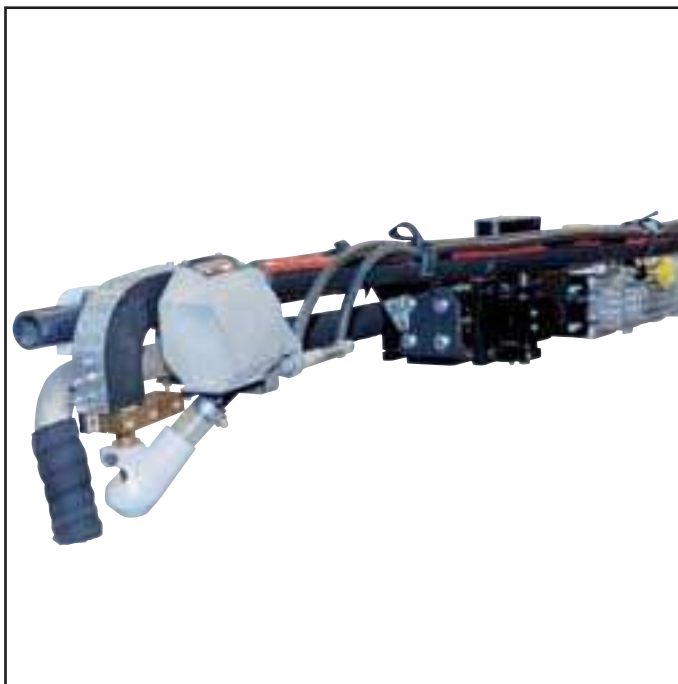

A6 S Compact

The A6 S Compact 300/500/700 are three reliable members of the A6 family for the efficient, high-productivity SAW method. These welding heads make it possible to build highly-efficient stations for the internal longitudinal welding of butt joints inside tubes in different versions for tubes down to dia 300 mm. TV-monitoring equipment can be integrated into the system, thereby enabling the operator to supervise and adjust the head position from the outside via the TV -screen.

A6 S Compact

Max load at 100% duty cycle, A	800
Wire diameter, mm	2.5, 3.0, 4.0
Wire feed speed standard, m/min	0.2-4.0
Wire feed speed high, m/min	0.4-8.0

Ordering information

A6 S Compact 300 welding head, standard	0809 280 880
A6 S Compact 500 welding head, high speed	0809 280 881
Option 40 flux valve control kit	0813 620 880
Inductive sensor	0811 178 880
TV monitoring equipment	0811 176 880
Laser pointer	0811 177 880



TAF AC power source

TAF welding power sources use a thyristor rectifier bridge to convert sinusoidal secondary voltage into a square wave output that has excellent arc ignition characteristics and good welding properties.

The excellent welding characteristics of the TAF series make these power sources ideal for submerged arc welding.

TAF 800

TAF 1250

Max output at 100% duty cycle, A	800	1250
Setting range, A/V	300/28-800/44	400/28-1250/44
Open circuit voltage, V	71	72
Efficiency at max current	0.86	0.86
Power factor at max current	0.75	0.76
Voltage, 1 ph 50 Hz, V	400/415/500	400/415/500
Voltage, 1 ph 60 Hz, V	400/440/550	400/440/550
Enclosure class, protection	IP 23	IP 23
External dimensions, LxWxH, mm	774x598x1228	774x598x1228
Weight, kg	495	608

Ordering information

TAF 800	0456 325 880
TAF 1250	0456 326 880
Fore more information please contact your nearest sales representative	

Welding automation

Power sources



LAF DC power source

LAF welding power sources have excellent welding characteristics throughout the entire current and voltage range. The starting and re-ignition characteristics are particularly good. These power sources demonstrate good arc stability at both high and low arc voltages. The continuously variable voltage control permits very precise adjustments of welding parameters.

LAF power sources produce a stable arc at very low currents and voltages. This means that they are ideal for submerged arc welding and metal arc welding.

	LAF 635	LAF 1000	LAF 1000M	LAF 1250	LAF 1250M	LAF 1600	LAF 1600M
Mains supply, V/Hz	400/50-60	400/50-60	400/50-60	400/50-60	400/50-60	400/50-60	400/50-60
Max output at 60% duty cycle, A	800/44	1000/44	1000/44	-	-	-	-
Max output at 100% duty cycle, A	630/44	800/44	800/44	1250/44	1250/44	1600/44	1600/44
Setting range, A/V, MIG/MAG	50/17-630/44	50/17-1000/45	50/17-1000/45	60/17-1250/44	60/17-1250/44	-	-
Setting range, A/V, SAW	30/21-800/44	40/22-1000/45	40/22-1000/45	40/22-1250/44	40/22-1250/44	40/22-1600/46	40/22-1600/46
Open circuit voltage, V	54	52	52	51	51	54	54
No load power, W	150	145	145	220	220	220	220
Efficiency at max current	0.84	0.84	0.84	0.87	0.87	0.86	0.86
Power factor at max current	0.90	0.95	0.95	0.92	0.92	0.87	0.87
Voltage, 3 ph 50 Hz, V	400/415	400/415/500	230/400/415/ 500	400/415/500	230/400/415/ 500	400/415/500	230/400/415/ 500
Voltage, 3 ph 60 Hz, V	440	400/440/550	230/400/440/ 550	400/440/550	230/400/440/ 550	400/440/550	230/400/440/ 550
Enclosure class, protection	IP 23	IP 23	IP 23	IP 23	IP 23	IP 23	IP 23
External dimensions, LxWxH, mm	670x490x930	646x552x1090	646x552x1090	774x598x1428	774x598x1428	774x598x1428	774x598x1428
Weight, kg	260	330	330	490	490	585	585

Ordering information

LAF 635	0457 350 880
LAF 1000	0456 321 881
LAF 1000M	0456 321 882
LAF 1250	0456 323 880
LAF 1250M	0456 323 881
LAF 1600	0456 324 880
LAF 1600M	0456 324 881

For more information please contact your nearest sales representative

Welding automation

Carriers and gantries



A2/A6 Beam-travelling carriage

For many applications, a beam-mounted carriage, fitted with an A2 or A6 welding head, is the ideal solution for submerged arc and gas metal arc welding.

The beam-bound carriage has a robust, cast-metal chassis with the possibility to mount a standard A2S or A6S welding head.

A2/A6 Beam-travelling carriage

Travel speed, m/min	0.06-2.0
Weight, kg	60

Ordering information

For ordering information, please contact your nearest ESAB representative.



MechTrac 1730, 2100, 2500 and 3000

MechTrac might very well be the most flexible and fastest way to increase your productivity. The MechTrac is built as a gantry and can be equipped with an A2 welding equipment for SAW or MIG/MAG to create a complete welding station. If the workpiece rotates, other welding methods such as TIG and plasma can be used, depending on the application and handling equipment.

The MechTrac unit is suitable for different types of workpieces that can be covered by a gantry. The gantry offers the possibility to weld profiles such as I-, T-, or L-beams, columns or tapered beams. The MechTrac is available in five versions, depending on the size of the workpiece. The difference is the width of the gantry – 1730 mm, 2100 mm, 2500 mm or 3000 mm between the legs and number of driving motors.

The length of the legs is the same for all types, 1500 mm from the top of the rail to the inside of the overhead beam.

The gantry can support a maximum weight of 220 kg, corresponding to a maximum of two A2 welding heads (single or twin wire) complete with automatic joint tracking GMD and an OPC flux recovery unit.

MechTrac 1730, 2100, 2500 and 3000

Travel speed, m/min	0.2-1.9
Rail length, m	3
Max load, kg	220

Ordering information

MechTrac 1730, single drive	0809 670 880
MechTrac 1730, dual drive	0809 670 881
MechTrac 2100, dual drive	0809 670 882
Mech Trac 2500, dual drive	0809 670 883
MechTrac 3000, dual drive	0809 670 884
Travelling rail, 3 m	0806 707 880
Rail, 3 m to extend the travelling rail	0806 707 881

Welding automation

Carriers and gantries



Walltrac

This column and boom welding station is designed for the production of various beam structures, such as I/H and box beams of tapered and non-symmetrical designs, stiffener sections and the joining of plates and sections. The flexible solution also permits quite a number of other applications to improve productivity and weld quality.

The wall-supported manipulator travelling on a single rail is designed for rack-and-pinion drive from the floor-mounted rail. An idler wheel support mounted on the column allows the manipulator to travel on a rail support.

To ensure a uniform, stable welding speed, the bogie carriage is equipped with two parallel-connected DC motors. The fixed boom, which has rails and a rack, is equipped with two motorised side-running welding carriages, each carrying a twin-wire sub-arc-welding head. Each welding head is fitted to a servo-controlled slide which is cross-mounted on the carriage via a manually-adjusted vertical boom. Transverse welding with the speed generated from the side-running carriage is possible, using the outer welding head.

The well-proven A6 welding heads incorporating the user-friendly, microprocessor based PEH are a combination which safely secures the welding process. Automatic joint tracking GMD controls the vertical and horizontal axes, i.e. the slides and the carriages, to safeguard the superior weld quality.

Advantages: Minimal floor working area thanks to the single rail/wall support. Longitudinal and transverse welding procedures can be used. A large number of positioning axes permit flexible welding production.

Ordering information

For ordering information please contact your nearest ESAB representative.



Gantrac

This gantry has rigid legs supported by tacho-controlled bogie carriages with cable chains to ensure a uniform, stable welding speed. The two legs support the gantry beam, which is equipped with guides and a rack for the two motorised welding carriages. The operator can easily control the welding procedure from the platform mounted on one of the bogie carriages. All in all, this is a very sturdy and reliable manipulator solution. The well-proven A6 welding heads are mounted on rack-and-pinion slides with comprehensive working strokes to obtain good access to the workpieces. Incorporating the user-friendly, microprocessor-based PEH, the welding process is safely secured. Automatic joint tracking GMD controls the vertical and horizontal axes, i.e. the slides and the carriages, to safeguard the superior weld quality.

Submerged arc welding is the superior method for the applications intended for this station.

The flux-handling equipment can be operated conveniently, without time-wasting interruptions. At the same time as flux consumption is reduced, the workplace is kept clean and free from flux spillage.

Advantages: Highly stabilised manipulation of welding torches with optimised welding results.

A large number of positioning axes permit flexible beam production.

Ordering information

For ordering information please contact your nearest ESAB representative.

Welding automation

Wear parts

*Tandem head - see single head SAW
tw = twin wire, s = single wire, G = GMAW

		A2 Multitrac		A6* Mastertrac		A2 Mini Master		A6* Arc Master		A6 Compact
		SAW	G	SAW	G	SAW	G	SAW	G	SAW
		s	tw	s	tw	s	tw	s	tw	single
Contact nozzles wire size										
Ordering information										
M6 0.8 mm	0153 501 002		•		•		•		•	
M6 1.0 mm	0153 501 004		•		•		•		•	
M6 1.2 mm	0153 501 005	•		•		•		•		
M6 1.6 mm	0153 501 007	•	•	•	•	•	•	•	•	
M6 2.0 mm	0153 501 009	•		•		•		•		
M6 2.4 mm	0153 501 010	•				•				
M10 0.8 mm	0258 000 914									
M10 1.0 mm	0258 000 913									
M10 1.2 mm	0258 000 908									
M10 1.6 mm	0258 000 909		•		•		•		•	
M10 2.0 mm	0258 000 910		•		•		•		•	
M10 2.4 mm	0258 000 911		•		•		•		•	
M10 3.2 mm	0258 000 915		•		•		•		•	
M12 1.6 mm	0154 623 008	•		•		•		•		
M12 2.0 mm	0154 623 007	•		•		•		•		
M12 2.4-2.5 mm	0154 623 006	•		•		•		•		
M12 3.0 mm	0154 623 005	•		•		•		•		
M12 4.0 mm	0154 623 003	•		•		•		•		

Adapter M6/M10

Ordering information

Adapter M6/M10	0147 333 001		•		•		•		•	
----------------	--------------	--	---	--	---	--	---	--	---	--

Contact jaws D35

Ordering information

2.0 mm L=65 mm	0332 581 880									•
2.4-2.5 mm L=65 mm	0332 581 881									•
3.0 mm L=58 mm	0265 900 880		•					•		•
4.0 mm L=58 mm	0265 900 882		•					•		•
5.0 mm L=58 mm	0265 900 883		•					•		
6.0 mm L=58 mm	0265 900 884		•					•		
1.6-3.2 mm L=75 mm	0265 901 480		•					•		

Contact jaws heavy twin

Ordering information

2 x 1.6 mm	0265 902 882		•		•		•		•	
2 x 2.0 mm	0265 902 881		•		•		•		•	
2 x 2.5-3.0 mm	0265 902 880		•		•		•		•	

Feed roller single wire size

Ordering information

0.8 mm	0145 538 881		•				•			
1.0 mm	0145 538 882		•		•		•			
1.2 mm	0145 538 883		•		•		•			
1.6 mm	0218 510 281	•		•	•	•	•			
2.0 mm	0218 510 282	•		•	•	•	•			•
2.4-2.5 mm	0218 510 283	•		•	•	•	•			•
3.0-3.2 mm	0218 510 298	•		•	•	•	•			•
4.0 mm	0218 510 286	•		•		•	•			•
5.0 mm	0218 510 287			•			•			
6.0 mm	0218 510 288			•			•			
3.0-5.0 mm Knurled V-groove	0218 510 299			•			•			

Pressure roller, single wire

Ordering information

Pressure roller, single wire	0153 148 880		•				•			
------------------------------	--------------	--	---	--	--	--	---	--	--	--

Welding automation

Wear parts



*Tandem head - see single head SAW
tw = twin wire, s = single wire, G = GMAW

Feed roller grooved

Ordering information

Tubular wire 1.2-1.6 mm 0146 024 880
Tubular wire 2.0-4.0 mm 0146 024 881

A2 Multitrac		A6* Mastertrac		A2 Mini Master		A6* Arc Master		A6 Compact
SAW	G	SAW	G	SAW	G	SAW	G	SAW
s	tw	s	tw	s	tw	s	tw	single
		•	•		•	•		•
		•	•		•	•		•

Pressure roller wire size

Ordering information

0.8-1.6 mm 0146 025 880
2.0-4.0 mm 0146 025 881
Shaft stud for above pressure roller 0212 901 101

		•	•		•	•		•
		•	•		•	•		•
		•	•		•	•		•

Feed roller twin wire size

Ordering information

2 x 1.2 mm 0218 522 486
2 x 1.6 mm 0218 522 488
2 x 2.0 mm 0218 522 484
2 x 2.4-2.5 mm 0218 522 480
2 x 3.0 mm 0218 522 481
2 x 2.0-3.2 mm Knurled U-groove 0148 772 880

	•			•				•
	•			•				•
	•			•				•
	•			•				•
				•				•
				•				•

Pressure roller, twin wire

Ordering information

Pressure roller, twin wire 0218 524 580

	•			•				•
--	---	--	--	---	--	--	--	---

MTW 600 MIG Torch

Contact nozzle M8

Ordering information

1.0 mm Fe, Ss, Cw / Al 0457 625 005
1.2 mm Fe, Ss, Cw 0457 625 006
1.2 mm Al 0457 625 007
1.4 mm Fe, Ss, Cw 0457 625 008
1.6 mm Fe, Ss, Cw / Al 0457 625 009
2.0 mm Al 0457 625 011
2.4 mm Fe, Ss, Cw / Al 0457 625 012

	•			•				•
	•			•				•
	•			•				•
	•			•				•
	•			•				•
	•			•				•
	•			•				•

A2 4WD Wire feeder

Feed roller single solid wire

Ordering information

0.6-0.8 mm Fe, Ss 0369 557 001
0.8-0.9 mm Al 0369 557 011
0.8-1.0 mm Fe, Ss 0369 557 002
1.0-1.2 mm Fe, Ss 0369 557 003
1.0-1.2 mm Al 0369 557 006
1.2-1.6 mm Fe, Ss 0369 557 007
1.4-1.6 mm Fe, Ss 0369 557 013
1.6 mm Al 0369 557 008
2.0 mm Al 0369 557 009
2 x 1.2 mm Fe, Ss 0369 557 010
Pressure roller (flat) 0369 728 001

	•			•				•
	•			•				•
	•			•				•
	•			•				•
	•			•				•
	•			•				•
	•			•				•
	•			•				•
	•			•				•

Knurled feed roller single wire

Ordering information

1.0-1.2/1.4-1.6 mm Cw 0369 557 004
1.4-1.6/2.0-2.4 mm Cw 0369 557 005
Pressure roller (knurled) 0466 262 001

	•			•				•
	•			•				•
	•			•				•

Welding automation

Components and modules



OCE-2 H cooling unit

The OCE-2 H water-cooling unit is an efficient, compactly-dimensioned cooling unit designed for use together with water-cooled equipment for arc welding by hand or in automatic plants. The water tank and pump is made of corrosion-resistant material.

OCE-2 H	
Mains supply, V/Hz	230/50-60
Cooling water, l/min	6
Max water pressure, bar	2.8
External dimensions, LxWxH, mm	320x270x360
Weight, kg	15

Ordering information

Cooling unit OCE-2 H	0414 191 881
Flowguard	0414 231 880



A6 synergic cold wire

The ESAB A6 – SCW SAW process

The ESAB A6-SCW kit offers a unique opportunity to increase the productivity by boosting the deposition rate. The cold wire is fed in synergy with the arc wire into a weld pool where it melts. This means that the arc and cold wire ratio always remains constant after a suitable wire diameter is selected. The chemistry of the weld and the deposition rate is controlled and pre-selected. It is easy for the operator to use as no additional control unit or separate feed device is needed.

The SCW process can be used in an endless variety of combinations with solid and/or cored wires, single, twin, tandem, and multiple wire applications and so on. It can also be used in surfacing applications with cored/solid wires such as concast rollers or built-up, large-diameter engine pistons. The cold wire has no arc and therefore carries no restrictions when it comes to incorporating "hard-to-weld" alloys in cored wires.

The cold wire kit is suitable for all ESAB's new and existing A6 systems and can be installed in a few minutes.

Slides

For the accurate and comfortable positioning of the welding head in the joint, the robust A2 and A6 slides are available in a series of standard lengths for any mounting position.

The A2 linear slides have a compact box profile and adjustable guides, which form a light and plain slide. The A6 linear slide is a flexible component and, with its high loading capacity, it can be freely mounted for positioning the A6 welding head. The A6 linear slide can also be supplied with an extended runner which increases loading capacity by 25%.

The A6 servo slide is primarily intended for use in connection with positioning and joint tracking. It can be operated jointly with other A6 components, such as rotary slides for the rotation of the welding head in the joint. These servo slides are normal supplementary units for our standard joint tracking systems, like the A6 GMD.

The ORB 40 is a rotary slide for the A2 welding head. It has a lockable rotary slide and compact design with a divided clamp. The A6 rotary slide with worm gear is used when the electrode angle requires frequent adjustment in relation to the joint. These adjustments can be made continuously from 0-360° using the hand-wheel. The A6 rotary ball bearing slide is another type designed for heavier loads. The rotary ball bearing disc can be rotated 360° and locked by a lever.



Welding automation

Components and modules



Wire feed units

The ESAB A2/A6 system comprises different wire feed units; A2 SAW, A2 GMAW, A6 SAW and A6 GMAW.

The A2 wire feed unit is designed for small wire submerged arc welding (SAW) or gas metal arc welding (GMAW) while operating in confined spaces.

The A2 SAW wire feed unit can be used for single or twin-wire welding. The A6 SAW wire feed unit is designed for heavy-duty welding. The wire feed unit is the standard base in most SAW automatics in the heavy production industry. You can use single or twin wire, strip cladding or arc-air gouging. The A6 GMAW wire feed unit is specially designed for the mechanisation of MIG/MAG welding in steel and aluminium. The GMAW version is robust equipment for heavy-production welding. It has a water-cooled torch mounted directly on the feed unit.

A2/A6 process controller PEH

The A2/A6 process controller PEH is a control box which can be used for SAW or GMAW welding together with A2/A6 automatic welding machines.

The control box is adapted to ESAB's LAF and TAF welding power sources. Extensive integration of the control system with the power source guarantees very high reliability in the welding process. The set parameters are monitored and error messages are transmitted when the tolerances are exceeded. All the controls required to control the welding motions and the entire welding process are located on the control panel.



A2/A6 process controller PEH

Enclosure class, protection	IP 23
External dimensions, LxWxH, mm	355x210x164
Mains supply, V/Hz	42 (AC)/50-60
Weight, kg	5.5
Max power consumption, VA	900

Ordering information

A2/A6 process controller PEH 0443 741 880

A2 process controller PEI

The A2 process controller PEI is a control system for ESAB A2 tractors and A2 welding heads. The controller is connected to the power source by a control cable and can be connected to the ESAB LAF 635 and LAF 1000.

The A2 process controller PEI is suitable for both submerged arc welding and gas metal arc welding. The control system is very easy to use with a minimum of training.



A2 process controller PEI

Enclosure class, protection	IP 23
External dimensions, LxWxH, mm	197x227x220
Mains supply, V/Hz	42 (AC)/50-60
Weight, kg	6.2
Max power consumption, VA	700

Ordering information

A2 process controller PEI 0449 330 880

Positioning and joint tracking system

The high-precision, heavy-duty A6 servo slide forms an important part of ESAB's automatic welding program. The slide is primarily intended for use in connection with positioning and joint tracking. Depending on the desired function and the work to be performed, the slide can be combined with two different control systems: PAK or GMD. The PAK is a manual, servo-assisted, joystick-controlled positioning and joint-tracking system for one or two slides. The GMD automatic joint-tracking system covers a wide range of applications and provides convenient handling. The basic function of the GMD is to correct irregularities in weld joints and to track simple workpiece geometries. You can also use sensor fingers with the GMD system to eliminate parallax faults.



Welding automation

Flux equipment



OPC Basic & Super

ESAB has a number of different flux equipment/systems to combine with our automatic submerged arc welding equipment. The OPC flux recovery units have a robust, compact design – easy to fit and easy to use. They can be fitted equally well to A2 and A6 equipment, both stationary or travelling. The OPC Basic recovery unit works on the ejector principle using compressed air.

Like the OPC Basic, the OPC Super recovery unit has been developed for use in a demanding working environment and on heavy-duty jobs. The OPC Super, with its stronger ejector and cyclone, produces higher suction height than the Basic. The OPC Super can also be used with pre-heated flux, as it is heat enforced.

There are three filter types for cleaning used air. A filter bag is used for A2 tractors and light-duty welding applications. A cyclone filter with a filter bag is a solution for most A2/A6 subarc welding. The Tedak filter is for heavy-duty and continuous welding applications.

To upgrade this system to a system for heavy continuous welding, add the FFS flux-feed system, and create the FFRS Basic & Super Flux system. For more information, see the leaflet entitled "FFRS – Basic & Super".

Technical data

OPC recovery unit Basic

Air-flow capacity at working pressure 0.6 MPa: 250 lit/min
Max suction height at working pressure 0.6 MPa: 0.8 m

OPC recovery unit Super

Air-flow capacity at working pressure 0.6 MPa: 300 lit/min
Max suction height at working pressure 0.6 MPa: 1.4 m

Ordering information

OPC Basic	0148 140 880
Air pressure hose 3/8", max 50 meters	0190 343 104
OPC Basic with cyclone filter	0802 415 882
OPC Basic with Tedak filter	0802 415 883
OPC Super with cyclone filter	0802 415 892
OPC Super with Tedak filter	0802 415 893
Air pressure hose 1/2", max 50 meters	0190 343 106
Filter tube diam. 63 mm, max 12 meters	0193 125 003

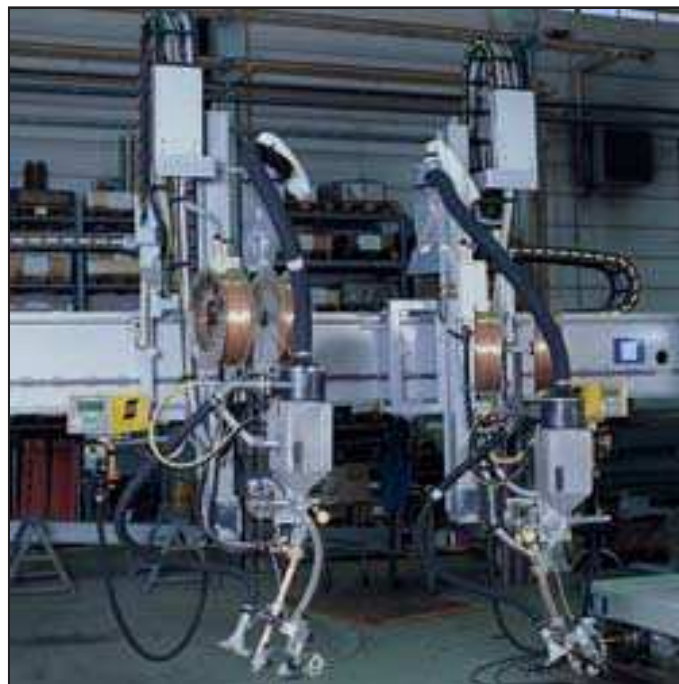

FFRS Basic & Super

The FFRS system is designed for continuous, high-capacity welding operations. It is ideal for long runs and mass production. The system is built on two different modules: the OPC Basic and Super, which are based on the ejector principle. The Basic type is for normal welding operation. The Super is used with increased flux bead and heat conditions.

FFRS – Basic & Super

These are recirculated systems for continuous Submerged Arc Welding. FFRS Basic/Super are complete equipment combining the effective recovery of flux with OPC Basic/Super systems and flux feed to the flux hopper with the well-known flux tank TPC 75. Added to ordering data is inlet pipe type, straight or bent, for easy connection to standard delivered aluminium hopper.

The system FFRS Basic and Super are built up from variants of OPC Basic/Super and Flux feed system FFS. The FFS comprises of a flux tank TPC with different inlets for the 6 and 10-litre flux hopper.

The system of FFS consists of:

Air flux feed tank TPC 75
Plastic hose 1" for flux, 30 meter
Inlet to flux hopper
Included in the package is an instruction of how to install inlet in hopper with drilling data.

Ordering information

FFS (straight inlet)	0806 697 887
FFS (bent inlet)	0806 697 886

Welding automation

Flux equipment



FFRS 1200 & 3000

The FFRS system is designed for continuous, high-capacity submerged arc welding operations. It is ideal for long runs and mass production. The FFRS 1200 & 3000 are based on an electric suction unit creating a vacuum, which is the alternative when extra high recovery force is required. In confined areas, they are the ideal flux-handling equipment. On the FFRS 1200 and 3000, there is an electrically-powered recovery unit. The recovered flux is cleaned from dust and slag in the pre-separator and passed back to the pressure tank for re-use. On the FFRS 1200, the power is 1200 W and, on the FFRS 3000, it is 3,000 W. The FFRS 1200/3000 is a flux feed and recovery system for heavy production SAW stations or submerged arc welding in confined spaces.

Technical data

FFRS 1200

External dimensions, LxWxH, mm: 1053x450x2210

Weight, kg, without flux: 230

FFRS 3000

External dimensions, LxWxH, mm: 750x450x2210

Weight, kg, without flux: 400

FFRS 1200 suction unit P160

External dimensions, LxWxH, mm: 480x400x1160

Fuse, slow, A: 10

Mains supply, V/Hz: 110-230/50-60 (others on request)

Weight, kg: 19

FFRS 3000 suction unit for E-PAK 150

External dimensions, LxWxH, mm: 1200x690x2000

Fuse, slow, A: 16

Mains supply, V/Hz: 400/3-phase, 50 Hz (others on request)

Weight, kg: 194

Ordering information

FFRS 1200	0801 500 901
FFRS 3000	0801 500 921
Air pressure hose 1/2", max 50 m*)	0190 343 106
Suction hose D47/38, max 12 m*)	0379 016 001

Accessories FFRS:

Bent inlet to flux hopper	0186 961 881
Straight inlet to flux hopper	0186 961 880

Extra hopper with inlet, see leaflet FFRS XA00104820

*) length according to customer requirements



CRE 30/60 air-drying units

- Reduces the risk of hydrogen cracking
- Built-in monitor – warns if the pre-set humidity is exceeded
- Reduces condensation – less corrosion and malfunction

The A6 CRE 30/60 air-drying units are designed for use with the ESAB flux handling system. The air-drying units work on the adsorption principle and is reactivated cold.

Most industries use compressed air as an energy source for many processes. For most of them, humidity is of no importance. The welding industry uses compressed air to transport flux for submerged arc welding. The necessity to keep these consumables dry is well known. The need to keep the humidity in the air at a low level is of the same importance as all the other precautions that are taken in a weld shop to limit the risk of hydrogen cracking.

The CRE 30/60 are air dryers for compressed air. It connects to the normal air distribution system at a plant. The capacity is sufficient to handle a delivery/recovery system for SAW. Thirty normal cubic metres per hour is the capacity at rated input for CRE 30. For CRE 60 the capacity is sixty normal cubic metres per hour.

The CRE 30/60 reduces the condensation of water in pneumatic systems and thereby reduces corrosion and malfunction.

Another advantage is the built-in monitor that emits a warning if the pre-set dewpoint of the air is exceeded.

Ordering information

CRE 30 air-drying unit	0443 570 880
CRE 60 air-drying unit	0443 570 881
Desiccant type 512, 10 kg	0443 570 017
Oil filter	0443 570 018
Dust filter	0443 570 019

Welding automation

Column and boom



CaB 300/460 S

CaB 300 S

The CaB 300 S (standard) column and boom can reach over distances of 3 to 5 m both vertically and horizontally. The 180° column rotation facility provides a total action radius. The 4x4 size is capable of 150 kg load at the end of the boom. The A2 and A6 welding systems are easily combined with the CaB 300 S.

CaB 460 S

The CaB 460 S (standard) column and boom can reach over distances of 5 to 7 m both vertically and horizontally. The 180° column rotation facility provides a total action radius. The 6x4 size is capable of 350 kg load at the end of the rack and pinion driven boom. The A2 and A6 systems are easily combined with the CaB 460 S.

Station solution 1 (standard)

solution for CaB 300/460 S and M) is a conventional column and boom with a movable boom and the welding head mounted at the end of the boom.

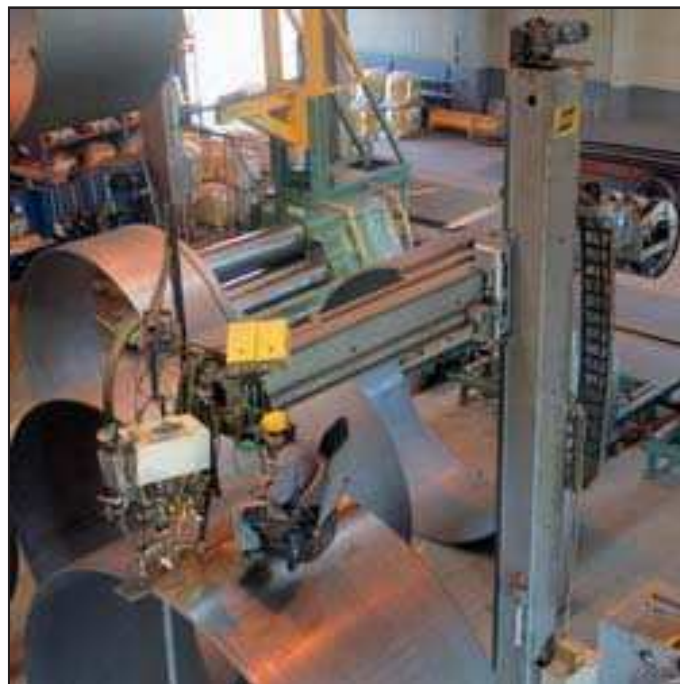
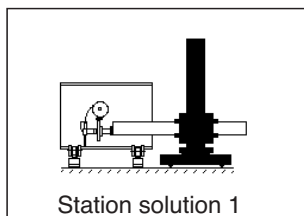

CaB 300/460 M

A modular range of column and booms, available in three load sizes. The modular system gives possibilities to configure a range of different welding station solutions that can fulfill most common welding applications.

Due to modularity and the fixed configuration possibilities the lead times for delivery can be kept at a minimum.

Station solution 1 (standard solution for CaB 300/460 S and M) is a conventional column and boom with a movable boom and the welding head mounted at the end of the boom.

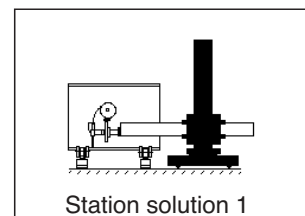

Welding automation

Column and boom



CaB 300/460/600 C

A customized range of welding column and booms are available for different customer requirements and applications, with loading capacities and working strokes for utmost accessibility to the welding joints.

Based on the modular CaB range, solutions to meet the most demanding request can be achieved. Welding methods as TIG, plasma welding and SAW cladding as well as Narrow Gap can be chosen on customized stations.

We can offer four basic stations with numerous alternatives.

Station solution 1 is a conventional column and boom with a movable boom and the welding head mounted at the end of the boom.

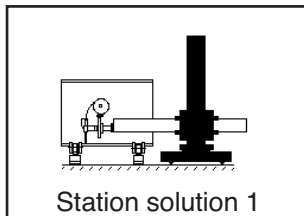

Station solution 2 is a conventional column and boom, with a movable boom and one welding head mounted at the end, combined with a boom-carriage-mounted welding head. (Not CaB 300).

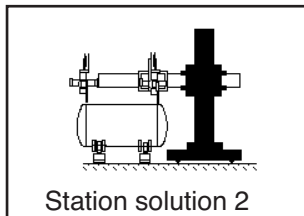

Station solution 3 side-boom manipulator with one or two welding heads. This welding station with 5-axes movement is the basic unit for welding girders and profiles and for joining plates and sections.

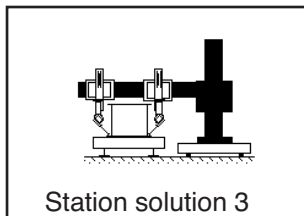

Station solution 4 is a side-boom manipulator with a double track boom. The welding heads are placed on each side of the boom. The boom carriages can be individually controlled by the joint tracking systems, on separate tracks. Positioning from the rail carriage helps to create a highly-efficient welding station for the transversal, double fillet welding of stiffeners, for example.

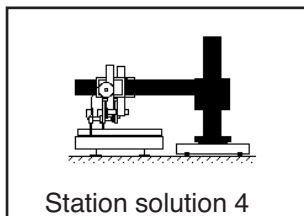

A2/A6 Circotech

A2/A6 Circotech is a motorised, fully-automatic welding machine designed for horizontal welds on tank walls, silos, blast furnaces, chimneys, cowpers, large penstocks and so on. The A2/A6 Circotech is available in either a single- or a double-sided version. The machine is equipped for submerged arc welding.

The A2/A6 Circotech is also designed for double wall tanks where one side is slimmed to pass between the walls.

The machine is very easy to set up and prepare for welding and is also easy to transport as a result of its compact frame and overall design.

Ordering information

For ordering information, please contact your nearest ESAB representative

Welding automation

Handling equipment



Roller beds

ESAB offers a wide range of roller beds – conventional roller beds with mechanical adjustment for circular workpieces and self-aligning roller beds which automatically adapt to the workpiece diameter. These roller beds are designed to operate in combination with A2/A6 automatic welding equipment and ESAB's column and booms.

ESAB's roller beds are designed and built for tough working environments.

All models meet or exceed the EN occupational safety requirements.

ESAB's TNA 5 – 500 conventional roller beds are a basic solution for the handling of a variety of workpieces. They occupy little space and feature quick and easy manual diameter adjustment by means of a screw. Rotation is even and certain since both axes of the power section are motorised.

ESAB's TA 10 – 500 Self-aligning roller beds are ideal for difficult and demanding workpieces. They provide even weight distribution and rotation plus adaptability to a wide range of diameters without separate adjustment. All four axles of the power section are motorised to ensure smooth rotation even in difficult conditions.

For windtowers and other conical workpieces, specially designed roller beds type 25, 40 and 70 TAW, are available.

ESAB's TXA 3 – 5 roller beds are the solution for applications, in which the centre height needs to be constant, despite diameter changes. The TXA-roller beds can also be used together with a positioner when welding long tubular workpieces. They are available as motorised or freely rotating idling units and all models can be supplied with rail bogies.

ESAB's S-series pipe roller benches are specially designed for the demanding job of rolling cylindrical objects, like pipes, during welding.

Their extensive diameter range, powerful rolling properties together with their compact design, make them the most ergonomically sound and versatile work benches available.

Versatile accessories

A wide range of accessories are available for ESAB's roller beds, which additionally improve workpiece handling during welding.

Ordering information

For ordering information, please contact your nearest ESAB representative.

Welding automation

Handling equipment



Positioners

ESAB has a comprehensive range of positioners for automatic welding, comprising seven standard versions with capacities ranging from 250 to 100,000 kg (larger units available on request). These very versatile handling tools enable welding to be carried out in the optimum positions to benefit the quality of the work and are easily integrated with A2/A6 automatic welding equipment.

ESAB welding positioners are designed and built for tough engineering workshop conditions and come with a low voltage (24 V) remote control unit for all functions. For daily work, these new positioners offer perfect solutions with optimised components and design.

ESAB 250-35000 AHMA positioners: For lifting, rotating and tilting demanding work pieces. Height, angle and speed are steplessly adjustable, thus guaranteeing the ideal ergonomic working position.

They have 3 axis: height, tilting angle and rotation. Thus 3-axis operation is guaranteeing the ideal ergonomic working position.

ESAB 3500-100000 FA positioners: For handling big and heavy objects. They have good loading characteristics in both rotation and tilting and their robust frame ensures safety at all times.

They have 2 axis: angle and rotation speeds are steplessly adjustable. Thus 2-axis operation is guaranteeing the ideal ergonomic working position of big and heavy objects.

ESAB 150 SKA positioner: For ergonomic handling of difficult workpieces. Adjustable rotation speeds and large tilting angle produce excellent welding results.

For daily work, this positioner offers perfect solutions with optimised components and design. SKA 150 positioner has 3-axis: manual height adjustment, manual tilting angle adjustment and motorised rotation. The wide adjustments of the 150 SKA positioner guarantee the ideal ergonomic working position.

ESAB 750-10000 SHA positioners: For highly demanding tasks with heavy workpieces. Workpieces can be placed in all positions on the SHA-positioner, most often around their centre of gravity. This ensures that the working position of the welder is always effective and ergonomically sound.

For daily work, these new positioners offer perfect solutions with optimised components and design. They have 3-axis:

height, tilting angle and rotation. Thus 3-axis operation is guaranteeing the ideal ergonomic working position.

ESAB 750-50000 head and tailstocks: For handling long objects. These positioners are efficient and productive for circumferential welding and for assembly of difficult workpieces. The head & tailstocks are versatile: you can use only headstock with or without tailstock. In addition the head and tailstock can be equipped with stepless height adjustment and tailstock with motorised railbogie for variable lengths of workpieces (when tailstock is used with railbogie, headstock requires height extension module).

ESAB 25000-50000 CRA positioners: For highly demanding tasks with really heavy workpieces. Workpieces can be placed in all positions, most often around their centre of gravity. This ensures that the working position of the welder is always effective and ergonomically sound.

They have 2-axis: rotation and tilting. Thus 2-axis operation is guaranteeing the ideal ergonomic working position or the best position to mechanised welding with column and boom.

ESAB 750-50000 VA horizontal positioners with fixed height enable the automated circumferential welding of heavy and large workpieces. Special large table plates or fixing crosses are available on request. They have motorised rotation of the table plate, thus offering economical solution for circumferential welding.

Speed control, drives and hydraulics: On the positioners AHMA, FA and VA the rotation speed and on SHA and CRA the rotation and tilting speed is adjustable by means of a new inverter. The new technique of vector inverter improves accuracy and offers better rotation torque at very low rotation speeds. For these positioners (AHMA above 2500N capacity) all drives are equipped with AC-motors, which requires less maintenance, no carbon-brush to change. The hydraulics is equipped with built-in safety valves against hose damages.

Versatile accessories: A wide range of accessories is available for ESAB's positioners, which additionally improves the workpiece handling during welding.

Ordering information

For ordering information, please contact your nearest ESAB representative

Welding automation

Seamers



Seamers for external welding

For external longitudinal welds of plates and cylindrical workpieces

- Heavy-duty backing with water-cooling

ESAB ED15H10

Nominal length: 1500 mm
Welding length: 1750 mm
Minimum diameter: 180 mm
Maximum diameter: 1000 mm

ESAB ED20H10

Nominal length: 2000 mm
Welding length: 2250 mm
Minimum diameter: 180 mm
Maximum diameter: 1000 mm

ESAB ED30H10

Nominal length: 3000 mm
Welding length: 3250 mm
Minimum diameter: 250 mm
Maximum diameter: 1,000 mm

ESAB ED40H10

Nominal length: 4000 mm
Welding length: 4250 mm
Minimum diameter: 350 mm
Maximum diameter: 1000 mm

ESAB ED60H10

Nominal length: 6000 mm
Welding length: 6250 mm
Minimum diameter: 600 mm
Maximum diameter: 1000 mm

- Plate thickness 1-8 mm
- With tack welds up to 10 mm plate thickness
- Extension blocks available for larger diameters
- Welding methods: SAW, GMAW, GTAW or plasma



Seamers for internal welding

For internal longitudinal welds of plates and cylindrical workpieces

- Heavy-duty backing with water-cooling

ESAB ID40H10

Nominal length: 4000 mm
Welding length: 4250 mm

ESAB ID60H10

Nominal length: 6000 mm
Welding length: 6250 mm

- Minimum workpiece \varnothing 1500 mm
- Plate thickness 1-8 mm
- With tack welds up to 10 mm plate thickness
- Welding methods: SAW, GMAW, GTAW or plasma

Welding automation

Engineering, Arc Welding



Beam welding

ESAB has more than 30 years' experience in the field of beam and profile welding. ESAB's beam and profile machines are equipped with the well-known and well-proven ESAB A6 system welding equipment.

ESAB offers you a complete and effective way of welding beams and profiles. Whether you weld I-, T- or L-beams, wide flange beams, columns, tapered beams or non-symmetrical beams, ESAB has the know-how and the welding equipment to match your efficiency, quality, precision, versatility, productivity and overall welding economy requirements.

The machines are of two types: IT-machines, where the beams are welded with the web unit in the vertical position, and I-machines, where the beams are produced in the horizontal position.

The main advantage of both machine types, apart from their high production capacity, is that the welding operation takes place when the flange and the web are pressed together under pressure in order completely to eliminate the gap between the surfaces. This ensures perfect weld quality.

The IT-machines have a built-in straightening device which compensates for the pull-back of the flanges (see picture). ESAB's beam-welding machine program gives you the opportunity to choose the right type of equipment for your particular type of production.

Total range of beam sizes that can be welded:

Height 200-3,200 mm

Width 100-1,600 mm

Ordering information

For more information please contact your nearest ESAB representative

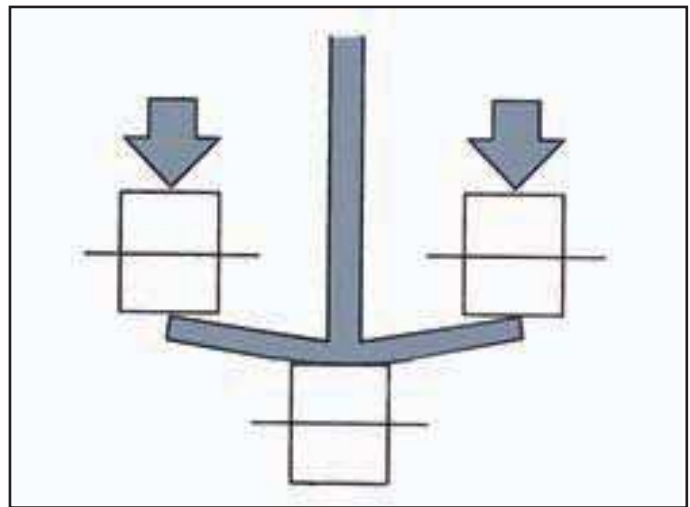

Straightening principle

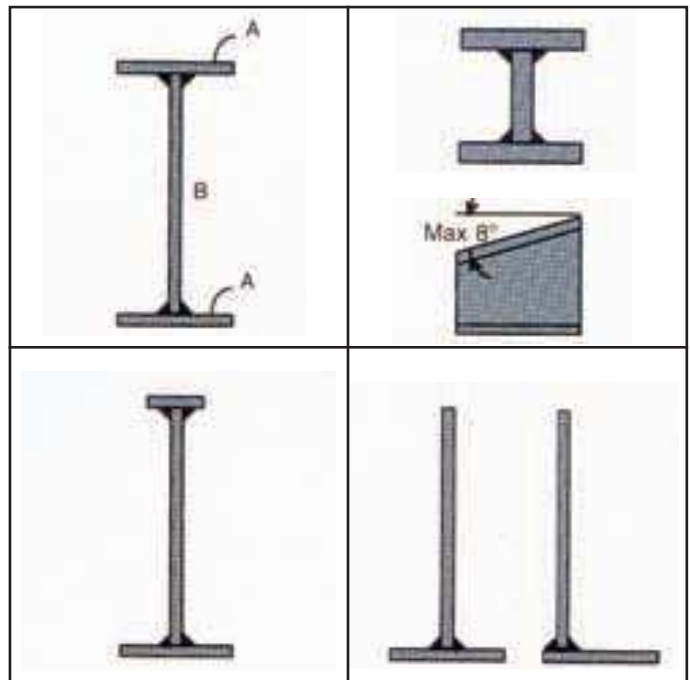

Examples of beams that can be welded

Welding automation

Engineering, Friction Stir Welding



Friction Stir Welding

ESAB has extended its product programme to include machines for the Friction Stir Welding method (FSW). This method has been developed and patented by TWI in the UK.

The FSW method is based on the principle of obtaining sufficiently high temperatures to forge two aluminium components, using a rotating tool that moves along the joint.

Using the FSW method, aluminium components are joined together without increasing the temperature above melting point.

The Friction Stir Welding of aluminium has been shown to produce joints with high-strength values and without inclusions and impurities.

Bending tests and tensile tests have been conducted with superb results. The fatigue properties are outstanding compared with other welding methods.

Furthermore, the joint is almost free from stress and has a perfect root surface when welded from one side. This results in a minimum of supplementary work.

Friction Stir Welding is ideal for joining straight profiles and flat plates with a thickness of 1.2-25 mm. When welding materials with a thickness of more than 15 mm, the welding is done from both sides. The maximum thickness is around 60 mm at 100% penetration.

Suitable application areas:

- Shipbuilding
- Offshore platforms
- Aerospace industry
- Railway wagons, trams, underground train carriages
- Automotive industry
- Production of electric motors
- Defence industry
- Cooling elements
- Basically all aluminium, copper and magnesium alloys can be friction stir welded with high quality and speed.

The picture shows an installation of a SuperStir™ at DanStir ApS, Copenhagen, Denmark.



LEGIO™

The ESAB LEGIO™ concept combines the latest technology with proven quality. The modular system makes it possible to assemble welding stations to suit the most varied friction stir welding applications.

The LEGIO™ system consists of five basic designs in a series of seven sizes, covering a welding depth of 1.2 mm to 60 mm. These basic types can be supplemented with different types of equipment to suit the most varied production needs and give maximum flexibility to any production line.

The S- and the U-models are designed to be easily integrated with larger fixtures, rotary units and exchangeable clamping systems.

For the production of smaller workpieces, the UT- and the ST-model are the most suitable. They have tables prepared with a hole pattern, where fixtures can be attached.

SuperStir™

The ESAB SuperStir™ programme includes a variety of machines developed from a standardized ESAB SuperStir™ base unit and with working ranges of 0.5 x 1.5 m up to 10 x 20 m within the same concept.

The programme also includes customized models of different designs to meet our customers specifications in their different production areas.

These different designs are today used worldwide in R&D centers, in joining of extrusions to panels, in production of pressure vessels as well as small parts for the automotive and electronic industries etc.

Welding Automation

Engineering, Resistance Welding



Flash butt welding

ESAB manufacture a complete series of flash butt welding machines for different welding objects with a welding area of 500 mm² up to 30,000 mm².

The flash butt welding technique is especially convenient and profitable for precision and mass production work as it permits a high level of mechanization and automation of the manufacturing process.

Our engineers have designed and constructed plants and turn-key projects all over the world.

ESAB's resistance welding program

Chain-making installations, type Carousel

- Size 5 Ø 18-47 mm
- Size 6 Ø 25-63 mm
- Size 7 Ø 30-81 mm
- Size 8 Ø 60-107 mm
- Size 9 Ø 80-127 mm
- Size 10 Ø 90-173 mm

Fully automated chain-making plant type ZAC

- ZAC 554 Ø 18-34 mm
- ZAC 42M Ø 18-42 mm

Chain-welding installation, type Rocat

- WT 18-26 Ø 18-26 mm
- WT 22-36 Ø 22-36 mm

Fully automatic link-bending plant, type YLNB

- YLNB 451 Ø 14-26 mm
- YLNB 552 Ø 22-36 mm

Flash butt welding machines, type SVU-K

- 5883-K Welding areas 1,400 mm²
- 6883-K Welding areas 2,000 mm²
- 7883-K Welding areas 5,000 mm²
- 8883-K Welding areas 8,000 mm²
- 9883-K Welding areas 10,000 mm²

The figures are based on an upsetting force of 5 kp/mm²

Resistance heaters, type ZSM

- ZSM 055-360 Ø 14-26 mm
- ZSM 155-800 Ø 18-36 mm
- ZSM 155-640 Ø 16-34 mm
- ZSM 255-640 Ø 17-47 mm
- ZSM 355-1200 Ø 30-81 mm
- ZSM 555-1500 Ø 60-107 mm
- ZSM 654-2400 Ø 80-140 mm
- ZSM 754-3200 Ø 90-173 mm

Chain-bending machines, type ZKBH

- ZKBH 25 Ø 17-56 mm
- ZKBH 45 Ø 30-96 mm
- ZKBH 55 Ø 60-128 mm
- ZKBH 65 Ø 80-152 mm
- ZKBH 75 Ø 90-173 mm

Rail-welding machine, type ZFR

- ZFSC 10 Welding areas 12,000 mm²
- ZFR 10 B Welding areas 10,000 mm²
- ZFR 11 GC Welding areas 12,000 mm²

Flash butt welding machine for tubes, type SVU

- SVU 7884-H Welding areas 2,300 mm²
- SVU 8884-H Welding areas 3,600 mm²

Flash butt welding machines for repair anode studs in the aluminium industry

- SVU 9883-S Ø 140 mm
- ZF 12 AA Ø 160 mm

Welding automation

Welding solutions delivered by Automation



Column and boom station for welding wind turbine tower sections

Wind turbine tower sections are bolted together using hot rolled steel flanges, which are welded to the end of each tower section. This installation consists of a column and boom equipped with an A6 submerged arc welding head for high productive welding of end flanges. The tower section is placed on a roller bed and is rotating, creating the actual welding speed. (The welding head will be kept in same position during the whole welding operation).

The complete sections produced in this specific installation can have a length up to 40 meters, a diameter up to 5 meters and have a total weight of more than 50 tonnes.



Column and boom station for welding dish ends for chemical and petrochemical reactors

The weld object, which is clamped to a positioner table, is tilted during the weld operation. Thanks to integrated motions between the positioner and a boom-travelling welding head, the welding speed can be kept constant. Dimensions of the weld objects: Dish end diameter: 3,000-8,000 mm. Wall thickness: 30-80 mm.

The station comprises the following: CaB 600, 10x6 column and boom with an A6 welding head. Positioner with a capacity of 50 tonnes. Numerical control system.



Automated welding systems for internal and external longitudinal, spiral and circumferential pipe welding

These systems include ESAB's A6 sub-arc and GMAW (MIG) welding heads, Automatic Joint Tracking System, Slag Crusher (sub-arc), LAF/TAF power sources and Weldoc™ weld supervision and documentation system. Pipe turning and conveying lines are also available.

For example, circumferential (sub-arc): diameter range 600–3,000 mm. Wall thickness max. 120 mm. Sub-assembly: length 4 x 1,500-4 x 4,000, 1 x 14,000 mm.

For example, longitudinal (sub-arc): diameter range 600–3,000 mm. Wall thickness max. 120 mm. Sub-assembly length 1,500-14,000 mm + tabs.



Multi-head gantry stations for the energy and process segments

Welding heavy winch drums intended for the ship and offshore industry. The circumferential procedure is submerged arc welding with twin-flux cored wires. The shell of the drum is joined to various lengths using butt joints. The work can be performed with two welding heads simultaneously in operation. The station can also handle the longitudinal welding of shell sections.

Dimension of object: Shell diameter max. 3,500 mm. Length of drum max. 9,300 mm. Wall thickness max. 80 mm. The station comprises the following: stationary gantry with two motorised carriages each equipped with slide assemblies and a special A6 type of welding head. TV monitoring system for remote control from the floor level. Roller beds for support and weld rotation.

For more information please contact ESAB AB, Welding Equipment, fax no. +46 584 411721.

Welding automation

Welding solutions delivered by Automation

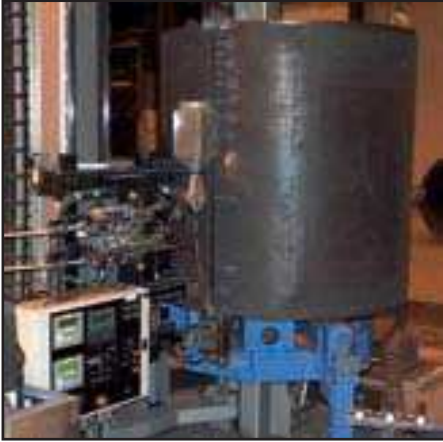

Electroslag welding machine

Machine for longitudinal welding of cylinders for the pulp industry. The picture shows a machine with the welded cylinder in the vertical position. The assembly is equipped with an inside-cooling support column for applying a cooling shoe to the closed joint of the upright cylinder.

The machine permits the welding of plates with a thickness of 40 mm to 450 mm, while using one to three electrode wires.



Stable gantry station with a width of 7,000 mm for welding stainless steel railway wagon roofs

The joints are of the overlap type without prior tack welding. A pneumatic clamping device ensures that the plates are tightened to each other during the MIG-welding procedure. An Aristo power source for pulsed welding sequences provides superior weld quality. An A2 welding head equipped with a durable and efficiently-cooled torch to withstand the very gruelling working conditions. Non-interrupted welding length of up to 30 metres at a rapid welding speed. The reverse speed is 10 m/min using efficient AC synchronous motors.



Column and boom station for welding turbines for hydropower in the energy segment

CNC-controlled welding manipulator with six programmable axes (teach in). Butt joining of the blades to the shaft of the turbine rotor. The complex approximately 4 m longitudinal preparation is curved in three dimensions. The process is twin-arc submerged arc welding. The working range of the manipulator is 2 x 4.3 x 2 m (vertical x longitudinal x transversal). The three remaining axes are integrated in the customised welding head.



A

A2 4WD Wire feeder, feed roller single solid wire	85
A2 Multitrac with A2 process controller PEI	76
A2 Multitrac with A2/A6 process controller PEH	76
A2 S GMAW Mini Master	78
A2 S Mini Master	78
A2 Tripletrac	75
A2/A6 Beam-travelling carriage	82
A2/A6 Circotech	91
A2 process controller PEI	87
A2/A6 process controller PEH	87
A21 PRB	58
A21 PRC	59
A21 PRD 100	59
A21 PRD 160	60
A21 PRH	60
A22 POC	61
A25	62
A25 components and accessories	65
A6 Mastertrac	77
A6 S Arc Master	79
A6 S Compact	80
A6 S Tandem Master	79
A6 synergic cold wire	86
A6-DK	77
Adapter M6/M10	84
Angular support	66
Aristo™ Arc 4000i/5000i, A4	4
Aristo™ Feed 3004/4804, MA4/MA6	29
Aristo™ Feed 3004/4804, U6/M0	29
Aristo™ Feed L3004 MA6 and M0 (Aristo™ U8)	28
Aristo™ MechControl 2 and 4	69
Aristo™ MechTig 4000iw	69
Aristo™ MechTig C2002i	68
Aristo™ Mig 4000i/5000i	24
Aristo™ Mig 4500i	24
Aristo™ Mig C3000i/L3000i	23
Aristo™ Mig U4000i/U5000i	25
Aristo™ RoboFeed 3004w	30
Aristo™ Tig 4000i	11
Aristo™ YardFeed 2000, MA6	31
AT1	46
AT1 CAN	45
AT1 CoarseFine	46
AT1 CoarseFine CAN	45

B

Balancing block	66
Beam welding	95

C

CaB 300/460 M	90
CaB 300/460 S	90
CaB 300/460/600 C	91
Caddy™ Arc 150i	3
Caddy™ Professional 200/250	4
Caddy™ Tig 150i/200i	9
Caddy™ Tig 2200i AC/DC	11
Collets and cartridges	64
Contact jaws D35	84

Contact jaws heavy twin	84
Contact nozzles wire size	84
CoolMidi 1800	48
CoolMini	48
Counterbalance device/mast	32
CRE 30/60 air-drying units	89

E

ESP 150	52
---------------	----

F

Feed roller grooved	85
Feed roller single wire size	84
Feed roller twin wire size	85
FeedSelector	31
FFRS 1200 & 3000 flux equipment	89
FFRS Basic & Super flux equipment	88
Flash butt welding	97
Frametrac™	73
Friction Stir Welding	96
FS 002	46
FS 002 CAN	46

G

Gantrac	83
---------------	----

I

Interconnection cables	33
Introduction orbital TIG	58

K

KHM 190 HS – petrol	7
KHM 190 YS – diesel	7
KHM 350 YS - CC/CV	8
KHM 595 PS – CC/CV	8
Knurled feed roller single wire	85

L

LAF DC power source	81
LEGIO™	96
LHF 400/630/800	5
LHF 405/615 PIPEWELD	6
Lifting eye	32
LPH 120 power cut	54
LPH 35 handy cut	53
LPH 50 power cut	53
LPH 80 power cut	54

M

M1	47
M1 10Prog CAN	46
MechTrac 1730, 2100, 2500 and 3000	82
MEI 10 wire feed unit	67
MEI 21 wire feed unit	67
Miggytrac 1001	74
Miggytrac 2000	74
Miggytrac 3000	75
MTA1 CAN	45
MTW 600 MIG Torch, Contact nozzle M8	85
MXH™ 300/400w PP	39
MXL™ Torches	38

N

Narrow gap head for PRD	66
-------------------------	----

O

OCE-2 H	49
OCE-2 H cooling unit	86
OPC Basic & Super flux equipment	88
Origo™ Arc 150i/200i	3
Origo™ Arc 250/300/400	5
Origo™ Arc 4000i/5000i, A2	4
Origo™ Feed 302/304/484, M11/M12	27
Origo™ Feed 304/484, M13	27
Origo™ Feed L3004, MA23/MA23A	28
Origo™ Feed L302/L304	26
Origo™ FeedAirmatic, M10	26
Origo™ Mag C140/C150/C170/C200/C250	17
Origo™ Mig 320	21
Origo™ Mig 400t/500t	22
Origo™ Mig 410/510	21
Origo™ Mig 630t MAGMA	22
Origo™ Mig C170 3ph/C200 3ph/C250 3ph	17
Origo™ Mig C240 PRO/C240s PRO	18
Origo™ Mig C280 PRO/C340 PRO	18
Origo™ Mig C3000i/L3000i	23
Origo™ Mig C420 PRO	19
Origo™ Mig L305/L405	20
Origo™ Tig 150i/200i	9
Origo™ Tig 3000i AC/DC, TA24AC/DC	12
Origo™ Tig 3000i, TA23	10
Origo™ Tig 3000i, TA24	10
Origo™ Tig 4300iw AC/DC	12
Origo™ YardFeed 200, M13y	30
OrigoCut 35i	50
Other equipment for MIG/MAG welding	33

P

PKB™ 250/400	38
Plasma gouging	55
POC 12-60 accessories	65
POC shafts and centering mandrels	65
Positioners	93
Positioning and joint tracking system	87
POWERCUT® 1500	51
POWERCUT® 650	50

POWERCUT® 875	51
Pressure roller wire size	85
Pressure roller, single wire	84
Pressure roller, twin wire	85
PSF™ 315M	37
PSF™ Centrovac self-cooled	36
PSF™ Centrovac water-cooled	36
PSF™ self-cooled	35
PSF™ water-cooled	35
PT 25	55
PT 26	55
PT 27	56
PT 30 KK	56
PT 31XL	56
PT 32EH	56

R

Railtrac 1000	70
Railtrac BV1000/BVR1000	72
Railtrac F1000	71
Railtrac FR1000	71
Railtrac FW1000/FW1000 L	71
Railtrac FWR1000	71
Remote Adapter 12	47
Remote Adapter 23	47
Remote control Mecht 1 CAN	66
Remote control MIG 2	47
Remote control MMA 1	47
Remote control MMA 2	47
Roller beds	92

S

Seamers for external welding	94
Seamers for internal welding	94
Slides	86
Standard racks for PRD 100	63
Standard racks for PRD 160	63
Strain relief for welding torch	32
SuperStir™	96

T

T1 Foot CAN	46
TAF AC power source	80
Tigaid 315 AC/DC	13
Torch guide kits	55
TIG torches and components	16
Tramtrac™ II	72
Turning piece	32
TXH™ 120, 120V, 120F	13
TXH™ 150, 150V, 150F	14
TXH™ 200, 200V, 200F	14
TXH™ 250w, 250wF, 400w, 400w HD	15
TXH™ remote torches	15

W

Walltrac	83
Wear part kits	55
Wear parts A2/A6	84, 85
Wear parts for wire feeders	34
Welding solutions delivered by Automation	98
Wheel kit	32
Wire feed units	87

World leader in welding and cutting technology and systems.



ESAB operates at the forefront of welding and cutting technology. Over one hundred years of continuous improvement in products and processes enables us to meet the challenges of technological advance in every sector in which ESAB operates.

Quality and environment standards

Quality and the environment are two key areas of focus. ESAB is one of few international companies to have achieved the new ISO 14001 standard in Environmen-

tal Management Systems across all our global manufacturing facilities.

At ESAB, quality is an ongoing process that is at the heart of all our production processes and facilities worldwide.

Multinational manufacturing, local representation and an international network of independent distributors brings the benefits of ESAB quality and unrivalled expertise in materials and processes within reach of all our customers, wherever they are located.



Find out more on www.esab.com



ESAB AB
Box 8004
S-402 77 Göteborg
SWEDEN
Phone: +46 31 50 90 00
info@esab.se
www.esab.com

*ESAB reserves the right to alter specifications without prior notice.
ESAB is approved according to ISO 9001:2000.*