

RENOLD

TRANSMISSION CHAIN

www.renold.com

Renold Chain Product Range



Transmission Chain

- British, ANSI, API, DIN, ISO and Works Standard Chains
- Adapted Chains
- Extended Pitch Chains
- Hollow Pin Chains
- Made to Order, Special Chains
- Mini Pitch Chains
- Nickel Plated Chains
- Oilfield Chains
- Plastic Bush Chains
- Power and Free Chains
- Polymer Block Chains
- Side Bow Chains
- Stainless Steel Chains
- Timing Chains

Applications

- Abattoirs ■ Air Conditioning ■ Aircraft - Civil & Military ■ Automotive
- Bakery Machines ■ Battery Manufacturing ■ Brewing ■ Canning ■ Carpet Machines
- Chart Tables/Marine ■ Chocolate Manufacturing ■ Concrete Moulding Equipment
- Copying Machines ■ Dairy Machinery ■ Drying Machinery ■ Earth Moving Equipment
- Extrusion Machines ■ Filtration Plants ■ Food and Drink Manufacture ■ Glass Manufacture
- Health Care Equipment ■ Hydraulic Components ■ Ice-Cream Manufacture
- In-Flight Refueling ■ Ingot Casting + Scrap Metal Processing ■ Latex Machinery
- Laundry Machinery ■ Lawnmower Manufacture ■ Mill Machinery ■ Mining
- MOT Brake Testing Machinery ■ Nuclear Power ■ Off Road Vehicles
- Oil Industry ■ Packaging Machines ■ Paper and Card Making ■ Paper Shredders
- Plastic Machinery ■ Potato Grading Machinery ■ Power Generation ■ Printing Machines
- Quarry Plant ■ Road Making/Plant Machinery ■ Robotic Systems ■ Roof Tile Manufacture
- Ship's Engines ■ Silkscreen Machinery ■ Ski-Lifts ■ Soot Blowers
- Steel Making ■ Straddle Carriers ■ Sugar Beet Machines ■ Sun-Blinds
- Telecommunications ■ Textile Machinery ■ Timber and Woodworking Machines
- Tin Printer Ovens ■ Tobacco/Cigarette Machinery ■ Tunnelling Machines
- T.V. and Audio Equipment ■ Tyre Manufacture ■ Waste Handling ■ X-Ray Equipment



Conveyor Chain

- British, ISO and Works Standard Chains
- Adapted Chains
- Agricultural Chains
- Bakery Chains
- Deep Link Chains
- Escalator Chains
- Made to Order, Specials
- Stainless Steel Chains
- Sugar Cane Chains
- Zinc Plated Chains

Applications

- Abattoirs ■ Agricultural Machines ■ Automotive ■ Bakery Machines ■ Bottle Washing Plants
- Brick & Tile Machinery OEM ■ Car Plants ■ Cement Plants ■ Chemical Plants
- Chicken Process Equipment ■ Cigarette/Tobacco Machinery ■ Dust Filters
- Egg Sorting Conveyors ■ Electrical Switchgears ■ Escalators ■ Extrusion Machines
- Feed Mill Machines ■ Feed Silo Equipment ■ Fibreglass Industry ■ Filtration Plants
- Fish Conveyor ■ Food Sterilisation ■ Food Processing ■ Freezing Equipment
- Freezing Tunnels ■ Glass Manufacturing ■ Grain Conveyor ■ Harvesting Machines
- Ice Cream Machines ■ Induction Furnaces ■ Ingot Casting + Scrap Metal Processing Mfr
- Latex Machinery ■ Leisure Rides ■ Luggage & Parcel Handling ■ Machine Tools
- Mail Sorting ■ Metal Casting ■ Mushroom Compost Machinery ■ Nuclear
- Ovens/Provers ■ Potato Grading Machinery ■ Potting Machinery ■ Quarries
- Radio Astronomy ■ Roof Tile Manufacture ■ Rope Machinery ■ Saw Mill Equipment
- Sewage Plants ■ Shaker Conveyors ■ Ski-Lifts ■ Sluice Gates ■ Steel Making
- Sugar Factories ■ Swarf Conveyors ■ Textile Machinery
- Timber and Woodworking Machines ■ Tool Changer ■ Tunnelling Machines
- Tyre Manufacture ■ Washing/Sterilising Machines ■ Water Treatment ■ Wire Belts

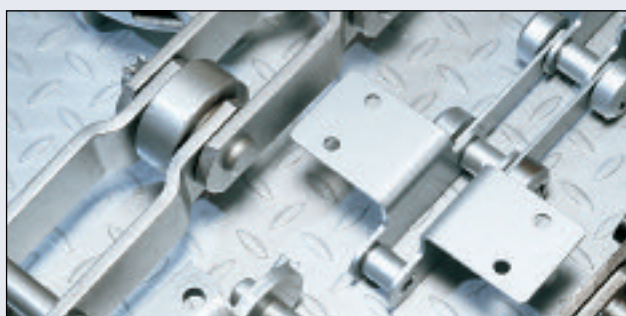

Leaf Chain

- LH(BL), AL, LL and Works Standard Chains

Applications

- Bottle Washing Plants ■ Car Plants ■ Cement Plants ■ Chemical
- Counterbalance Sets ■ Cranes ■ Dust/Swarf Conveyors ■ Elevators
- Food Processing ■ Food Sterilisation ■ Fork Lift Trucks ■ Pipe Line Valves/Taps
- Printing Machines ■ Rock Drilling ■ Straddle Carriers ■ Sun-Blinds ■ Tail Lifts



Section 1 - BS and ANSI products and dimensions

Precision roller chain / chain types	5
Chain branding	6
Renold Synergy brand	7
European (BS) Standard	
Renold Synergy chain	8
A&S Transmission Chain	10
Small and large pitch chain	12
Standard attachment chain	13
Renold Syno nickel plated chain	22
Renold Syno stainless steel chain	23
Renold Syno polymer bush chain	24
Renold Stainless steel chain	25
Renold Sovereign chain	26
Renold Hydro-Service chain	27
Straight side plate chain	28
Nickel plated chain	29
Cranked link chain	30
Hollow pin chain	31
Double pitch chain and Bush chain	32
Sidebow chain	33
ANSI Standard	
Renold Synergy chain	34
A&S Transmission Chain	36
Small and large pitch chain	38
Multiplex chain	39
Standard attachment chain	40
Renold Syno nickel plated chain	48
Renold Syno polymer bush chain	49
Renold Stainless steel chain	50
Renold Hydro-Service chain	51
Renold Ansi Xtra chain	52
Nickel plated chain	54
Hollow pin chain	55
Double pitch chain	56
Specials and Accessories	
Klik-Top chain	57
Polymer block chain	59
Renold Roll-Ring chain tensioner	64
Sprockets	67
Transmission counterweight sets	76
Transmission rack sets	77
Transmission chain guides	78
Rivet extractors and chain lubricant	79

Section 2 - Chain Installation and Maintenance

Chain Installation and Maintenance	80
--	----

Section 3 - Designer Guide

Designer Guide specification guidelines	93
---	----

Section 4 - Industry applications

Examples of Renold Chain in action	120
Word Index	134

RENOLD

SECTION 1

BS & ANSI PRODUCTS & DIMENSIONS

Precision roller chain, parts and connecting links

The Renold precision steel roller chain is a highly efficient and versatile means of transmitting mechanical power, which, in the field of industrial applications, has almost completely superseded all other types of chain previously used.

The illustration below shows component parts of the outer link and of the inner link of a Renold simple roller chain.



As illustrated, the Renold precision steel roller chain consists of a series of journal bearings held in precise relationship to each other by the constraining link plates. Each bearing consists of a bearing pin and bush on which the chain roller revolves. The bearing pin and bush are case hardened to allow articulation under high pressures, and to contend with the load carrying pressures and gearing action imparted via the chain rollers.

All chains are classified according to pitch (the distance between the centres of adjacent bearing pins), roller diameter and width between inner plates. Collectively, these dimensions are known as the gearing dimensions, as they determine the form and width of the sprocket teeth.

Standard links

The chain parts and connecting links illustrated are only indicative of the types available. Please refer to the appropriate product page for the parts relevant to individual chains.

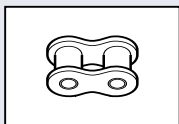

No. 4
Inner Link (BS/DIN)
Roller Link (ANSI)

These are complete assemblies for use with all sizes and types of chain. The unit consists of two inner plates pressed on to the bushes which carry the rollers. (Inner links for use with bush chains have no rollers).

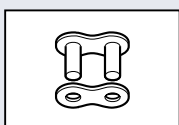

No. 107
Outer Link - Press Fit (BS/DIN)
Riveting Pin Link - Press Fit (ANSI)

For use with all sizes and types of chain where optimum security is desired. The link is supplied with bearing pins riveted into one outer plate. The other outer plate is an interference fit on the bearing pins, the ends of which should be riveted over after the plate is fitted.

Press fit connecting links should only be used once; new links must be used to replace dismantled links. (See 'Riveting Chain Endless' for full instructions).

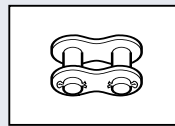

No. 11
Connecting Link - Slip Fit
(BS/DIN/ANSI)

A connecting link supplied with two connecting pins riveted into the outer plate. The outer plate is a clearance fit on the connecting pins and is secured in position by a split pin through the projecting end of each connecting pin.

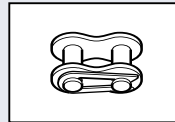

No. 26
Connecting Link - Slip Fit (BS/DIN/ANSI)

Used on short pitch chains only. Supplied with two connecting pins riveted into the outer plate, the clearance fit connecting plate being secured by means of a spring clip, No. 27, which snaps into the grooves in the pins.

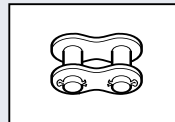

No. 58
Connecting Link - Press Fit
(BS/DIN/ANSI)

The standard connecting link for ANSI series detachable chains, also used on riveted chains where high speeds or arduous conditions are encountered. Supplied with two connecting pins riveted into the outer plate, the other outer plate being a press fit onto the pins and secured by split pins after assembly. Press fit connecting links can only be used once; new links must always be used to replace dismantled links.

Cranked links

Apart from the specialised chains where the cranked link is an essential design feature, cranked links are used only where the chain length must be an odd number of pitches. This practice is not recommended; all drives should, wherever possible, be designed with sufficient overall adjustment to ensure the use of an even number of pitches throughout the chain. **DO NOT USE CRANKED LINKS ON IMPULSIVE, HIGHLY LOADED OR HIGH SPEED DRIVES.**

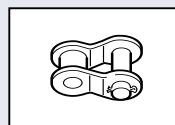

No. 12
Cranked Link - Slip Fit (BS/DIN)
Offset Link - Slip Fit (ANSI)

A single link with cranked plates pressed onto a bush and roller assembly at the narrow end. A clearance fit connecting pin (No. 128) is fitted at the wide end and is secured by a split pin.

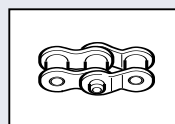

No. 30
Cranked Link Double (BS/DIN)
Two Pitch Offset Link (ANSI)

Double cranked links are available for most sizes and types of chain. The unit consists of an inner link (No. 4), with cranked links retained permanently in position by a riveted bearing pin.

Screw operated extractors break chain by forcing the Renold end softened bearing pins out of the outer link plates. For other brands of chain, the rivet swell must first be ground away.

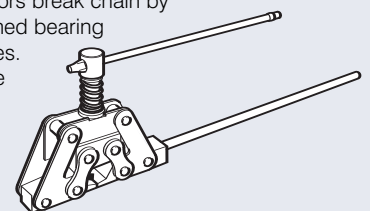

Chain brands from **RENOLD**

Reputation, experience, excellence

At Renold, we produce a wide range of chain products to meet differing application conditions, working loads and life expectations. To help distinguish between these products, we promote them under different brand names.



RENOLD Synergy

RENOLD brand chains

Our elite performance chain, with its unbeatable wear and fatigue resistance is branded Renold Synergy (see opposite page). Outside the size options of the Renold Synergy range (3/8" to 1.5", BS and ANSI standard) we have the small and large pitch chain, branded "Renold". Renold brand chain has earned a worldwide reputation for its introduction of features such as wide waisted plates, solid extruded bushes and rollers and improvements in wear resistance through precision manufacturing. The Renold range also covers all of our zinc and nickel plated chains, sidebow, extended pitch, bush and hollow bearing pin chains.



Other products, such as Renold Stainless Steel, Renold Syno 'No more lube' range, Renold Hydro-Service (corrosion resistance) and Renold Sovereign (abrasion resistance) all have their own distinct identities, having been specially developed for excellent performance in specific applications.

In the majority of markets around the world, Renold offers its customers a powerful combination of chain brands; Renold Synergy and A&S Chain. Renold Synergy, as described opposite, is our premium specification roller chain designed to provide high performance and long working life.



A&S is a first class all-purpose chain. In its supporting role to Renold Synergy, A&S Chain is the ideal choice for anyone looking to specify a solution that combines economy with genuine reliability and performance. What other brands in this category claim to provide, only A&S can deliver!



For more information about Renold's range of chain products, including our comprehensive range of conveyor chain, lifting chain and adapted or special chains, visit the Renold website, (www.renold.com), which also includes our Online Chain Products Catalogue - your interactive guide to chain information.

Simply the best

Quality, performance, value and now even better

Renold Synergy represents the biggest single innovation in power transmission technology since the bush roller chain was invented. Its wear resistance and performance capabilities are without equal.

At Renold our motivation is the constant pursuit of excellence. Even when we know that we are developing a truly exceptional design, we're not content to leave it at that. We haven't stopped our research and development of Renold Synergy since the day the idea was born. The expertise and experience of Renold's engineers and designers has brought about significant improvements to even this recognised world-beater!



Many thought there was no way to improve on such an innovative design but the latest development of Renold Synergy now represents a bold new evolution of a product that has already rewritten the rulebook!

Chain is too small a word to describe Renold Synergy. It has made, and continues to make, an unquestionable contribution to the

RENOLD Synergy

improved performance and reliability of drive systems all over the world.

Operational features and benefits - User friendly

- Renold Synergy is virtually dry to the touch, therefore the lubricant stays in the chain, not on your hands.
- Renold Synergy's special platinum-coloured connecting link contrasts with the black surface of the other plates, making for easy identification, ensuring rapid disconnection of the chain.
- Renold Synergy's unique soft pin ends allow quick and easy cutting to length without damaging the rest of the chain.
- Because Renold Synergy lasts longer and is more resistant to shock loading, it is the most reliable product of its kind; just fit it and forget it.



Operational features and benefits - Environmentally friendly

- Precious initial lubricant is primarily in the chain not on the outside where it's not needed.
- All packaging is 100% recyclable.
- All chain is 100% recyclable.
- Renold Synergy is made in factories that fully conform with ISO 14001.
- All material waste in production is recycled.

Wear Performance

Most correctly specified chain eventually has to be replaced due to elongation caused by wear between the pin and bush. Independent tests have shown that Renold Synergy out-performed the best of the recognised quality competitor chain by almost six times.

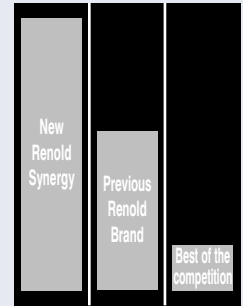

1

Fatigue Performance

Under conditions of continual heavy load or repeated shock loading, chain may need to be replaced due to breakage or fatigue. Tests have shown that Renold Synergy is significantly better than other leading brands. This is especially true as the loose fit connecting link plates were specially treated to achieve the same fatigue performance as the chain.

Renold Synergy fatigue performance is not only measured as a chain, but as a chain system.

Product features and benefits - Plates

- Precision blanked profile optimises stress distribution.
- Strict control of steel specification (including trace elements) to ensure very consistent heat treatment results.
- Triple punch holing techniques maximises resistance to crack propagation and ensures controlled positional location of pin and bush for even wear.
- Special coating gives improved corrosion and light acid resistance.
- Connecting link plates are specially treated to ensure the same fatigue performance as the overall chain.



PLATE PROFILE ACCURATE HOLING TECHNIQUES PIN BUSH ROLLER

Product features and benefits - Pin and Bush

- Optimised hardening to minimise wear but also prevent brittleness.
- Unique bush bore profile to ensure full contact between pin and bush bore surfaces.
- Three-stage pin surface treatment giving a unique combination of lubrication retention and extended wear life.
- Exclusive 6-stage cold extrusion process giving concentricity and material grain flow, optimising shock load resistance.

RENOLD Synergy® - BS Transmission Chain

ISO 606

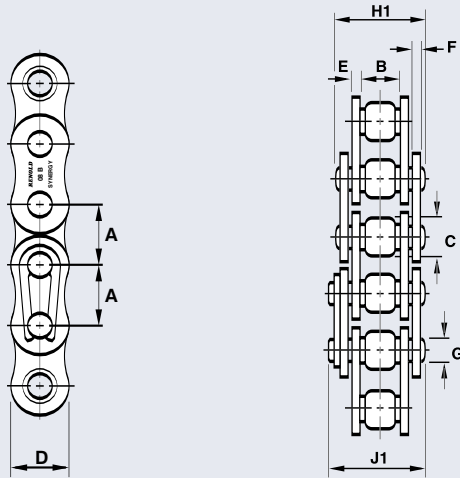

Renold Synergy® European BS Simplex Transmission Chain

Chain

Technical Details (mm)

Connecting Links

Renold Chain No	ISO No	Pitch	Pitch	Inside	Roller	Plate	Plate	Plate	Pin	Pin	Con	Renold	Weight	No	No	No	No	No	No	
		Inch	mm	Width	Dia	Height	Width	Width	Width	Dia	Len	Link	Exceeds	kg/m	4	107	11	26	12	30
		A	A	B	C	D	E	F	G	H1	J	ISO 606								
													Min							
													(N) ‡							
110038 ⊗	06B-1	0.375	9.525	5.72	6.35	8.26	1.3	1.04	3.28	12.5	3.3	8900	0.39	✓	✓	-	✓	-	✓	
111044	-	0.50	12.7	3.3	7.75	9.6	1.13	0.98	4.09	9.8	1.5	8900	0.30	✓	✓	-	✓	-	✓	
111046	-	0.50	12.7	4.88	7.75	9.6	1.13	0.98	4.09	11.4	1.5	8900	0.35	✓	✓	-	✓	-	✓	
110044	-	0.50	12.7	5.21	8.51	11.81	1.55	1.55	4.45	14.46	1.5	17800	0.7	✓	✓	-	✓	-	✓	
110046	08B-1	0.50	12.7	7.75	8.51	11.81	1.55	1.55	4.45	17.0	3.9	17800	0.70	✓	✓	-	✓	-	✓	
110054	-	0.625	15.875	6.48	10.16	14.73	1.55	1.55	5.08	16.0	1.3	22200	0.81	✓	✓	-	✓	-	✓	
110056	10B-1	0.625	15.875	9.65	10.16	14.73	1.55	1.55	5.08	18.8	1.3	22200	0.92	✓	✓	-	✓	-	✓	
110066	12B-1	0.75	19.05	11.68	12.07	16.13	1.8	1.8	5.72	21.9	1.1	28900	1.20	✓	✓	-	✓	-	✓	
110088	16B-1	1.0	25.4	17.02	15.88	21.08	4.12	3.1	8.28	34.9	2.2	60000	2.80	✓	✓	-	✓	✓	-	
110106	20B-1	1.25	31.75	19.56	19.05	26.42	4.62	3.61	10.19	39.8	2.7	95000	3.85	✓	✓	-	✓	✓	-	
110127	24B-1	1.50	38.1	25.4	25.4	33.4	6.1	5.08	14.63	52.6	6.8	160000	7.45	✓	✓	✓	-	✓	-	

⊗ STRAIGHT SIDE PLATES

‡ RENOLD SYNERGY CHAIN FAR EXCEEDS THE ISO606 MINIMUM TENSILE STRENGTH REQUIREMENT, BUT RENOLD DO NOT CONSIDER THAT THIS FIGURE PROVIDES A USEFUL INDICATOR TO THE KEY CHAIN PERFORMANCE AREAS OF WEAR AND FATIGUE.

For information on chain sizes smaller or larger than those shown here, please see page 12.



link no. 4



link no. 107



link no. 11



link no. 26



link no. 12



link no. 30

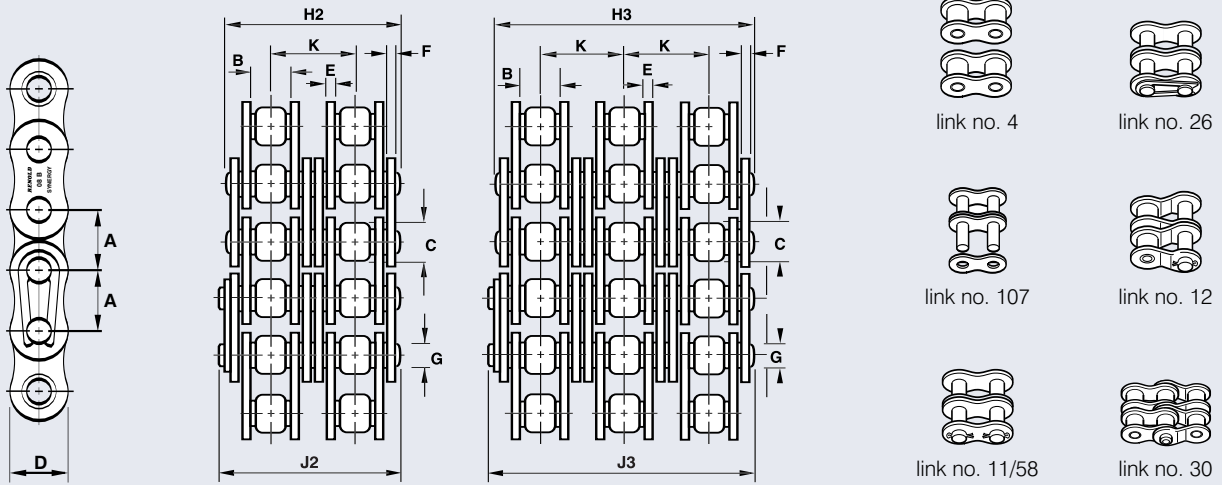

1

Renold Synergy® European BS Duplex Transmission Chain

Chain

Technical Details (mm)

Connecting Links

ISO No	Pitch Inch	Pitch mm	Inside Width Min	Roller Dia Max	Plate Height Max	Plate Width Inner	Plate Width Outer Max	Pin Dia Max	Pin Len Max	Con Link Extra	Trans Pitch Nom Max	Renold Exceeds ISO 606 Tensile Strength Min	Weight kg/m	Min (N) ‡	No 4	No 107	No 11	No 26	No 12	No 30
															A	A	B	C	D	E
06B-2	0.375	9.525	5.72	6.35	8.26	1.3	1.04	3.28	23.0	1.3	10.24	16900	0.74	‡	‡	-	‡	-	‡	
08B-2	0.50	12.7	7.75	8.51	11.81	1.55	1.55	4.45	30.4	1.5	13.92	31100	1.38	‡	‡	-	‡	-	‡	
10B-2	0.625	15.875	9.65	10.16	14.73	1.55	1.55	5.08	35.4	1.3	16.59	44500	1.80	‡	‡	-	‡	-	‡	
12B-2	0.75	19.05	11.68	12.07	16.13	1.8	1.8	5.72	41.4	1.1	19.46	57800	2.40	‡	‡	-	‡	-	‡	
16B-2	1.0	25.4	17.02	15.88	21.08	4.12	3.1	8.28	66.8	2.2	31.88	106000	5.50	‡	‡	-	‡	‡	-	
20B-2	1.25	31.75	19.56	19.05	26.42	4.62	3.61	10.19	76.7	2.7	36.45	170000	7.80	‡	‡	-	‡	‡	-	
24B-2	1.50	38.1	25.4	25.4	33.4	6.1	5.08	14.63	101.3	6.8	48.36	280000	14.80	‡	‡	‡	-	‡	-	

Renold Synergy® European BS Triplex Transmission Chain

Chain

Technical Details (mm)

Connecting Links

ISO No	Pitch Inch	Pitch mm	Inside Width Min	Roller Dia Max	Plate Height Max	Plate Width Inner	Plate Width Outer Max	Pin Dia Max	Pin Len Max	Con Link Extra	Trans Pitch Nom Max	Renold Exceeds ISO 606 Tensile Strength Min	Weight kg/m	Min (N) ‡	No 4	No 107	No 11	No 26	No 12	No 30
															A	A	B	C	D	E
06B-3	0.375	9.525	5.72	6.35	8.26	1.3	1.04	3.28	33.3	1.3	10.24	24900	1.10	‡	‡	-	‡	-	‡	
08B-3	0.50	12.7	7.75	8.51	11.81	1.55	1.55	4.45	44.3	1.5	13.92	44500	2.06	‡	‡	-	‡	-	‡	
10B-3	0.625	15.875	9.65	10.16	14.73	1.55	1.55	5.08	52.0	1.3	16.59	66700	2.54	‡	‡	-	‡	-	‡	
12B-3	0.75	19.05	11.68	12.07	16.13	1.8	1.8	5.72	60.9	1.1	19.46	86700	3.60	‡	‡	-	‡	-	‡	
16B-3	1.0	25.4	17.02	15.88	20.57	4.12	3.1	8.28	99.9	5.4	31.88	160000	8.15	‡	‡	-	‡	‡	-	
20B-3	1.25	31.75	19.56	19.05	26.04	4.62	3.61	10.19	116.1	6.1	36.45	250000	11.65	‡	‡	-	‡	‡	-	
24B-3	1.50	38.1	25.4	25.4	33.4	6.1	5.08	14.63	150.2	6.6	48.36	425000	22.25	‡	‡	‡	-	‡	-	

‡ RENOLD SYNERGY CHAIN FAR EXCEEDS THE ISO606 MINIMUM TENSILE STRENGTH REQUIREMENT, BUT RENOLD DO NOT CONSIDER THAT THIS FIGURE PROVIDES A USEFUL INDICATOR TO THE KEY CHAIN PERFORMANCE AREAS OF WEAR AND FATIGUE.

A&S BS Transmission Chain

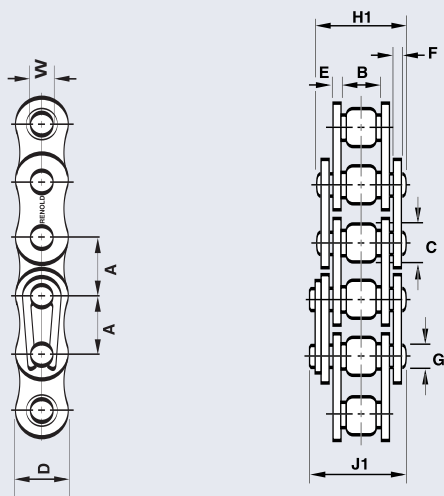

A&S BS Simplex Transmission Chain

Chain

Technical Details (mm)

Connecting Links

Renold Chain No	ISO No	Pitch Inch	Pitch mm	Inside Width Min	Roller Dia Max	Plate Height Max	Plate Width Inner Max	Plate Width Outer Max	Pin Dia Max	Pin Len Max	Con Link Extra Max	Trans Pitch Norm	ISO606 Tensile Strength Min (N) ‡	Weight kg/m	No 4	No 107	No 26	No 30	No 11/58	No 12
															A	A	B	C	D	E
100 00 02	03	0.197	5.00	2.50	3.20	4.10	0.57	0.57	1.49	7.40	2.50	-	2200	0.08	✓	✓	✓	✓	✓	-
100 00 03	04	0.236	6.00	2.80	4.00	5.00	0.57	0.57	1.85	7.40	2.90	-	3000	0.12	✓	✓	✓	✓	-	-
100 00 06	05B-1	0.315	8.00	3.00	5.00	7.10	0.73	0.73	2.31	8.60	3.10	-	4400	0.18	✓	✓	✓	✓	✓	-
100 00 15*	06B-1	0.375	9.525	5.72	6.35	8.20	1.25	1.00	3.28	13.50	3.30	-	8900	0.41	✓	✓	✓	✓	-	✓
100 00 24	081	0.500	12.70	3.30	7.75	9.90	1.00	1.00	3.66	10.20	1.50	-	8000	0.28	✓	✓	✓	✓	-	-
100 00 31**	08B-1	0.500	12.70	7.75	8.51	11.80	1.50	1.50	4.45	17.00	3.90	-	17800	0.70	✓	✓	✓	✓	-	-
100 00 40**	10B-1	0.625	15.875	9.65	10.16	14.70	1.50	1.50	5.08	19.60	4.10	-	22200	0.95	✓	✓	✓	✓	✓	-
100 00 50**	12B-1	0.750	19.05	11.80	12.07	16.10	1.76	1.76	5.72	22.70	4.60	-	28900	1.25	✓	✓	✓	✓	✓	✓
100 00 68**	16B-1	1.000	25.40	17.02	15.88	21.00	4.00	3.00	8.28	36.10	5.40	-	60000	2.70	✓	✓	✓	✓	✓	✓
100 00 75**	20B-1	1.250	31.75	19.56	19.05	26.40	4.40	3.50	10.19	43.20	6.10	-	95000	3.60	✓	✓	✓	✓	✓	✓
100 00 79**	24B-1	1.500	38.10	25.40	25.40	33.40	5.90	5.00	14.63	53.40	6.60	-	160000	6.70	✓	✓	✓	✓	✓	✓
100 06 15	28B-1	1.750	44.45	30.99	27.94	37.00	7.62	6.35	15.90	65.10	7.40	-	200000	8.60	✓	✓	-	-	✓	✓
100 06 17	32B-1	2.000	50.80	30.99	29.21	42.20	7.11	6.35	17.81	67.40	7.90	-	250000	10.50	✓	✓	-	-	✓	✓
100 06 20	40B-1	2.500	63.50	38.10	39.37	52.90	8.64	8.10	22.89	82.60	10.00	-	355000	16.00	✓	✓	-	-	✓	✓
100 10 34***	48B-1	2.999	76.20	45.72	48.26	63.80	12.19	10.16	29.24	99.10	10.00	-	560000	25.00	✓	✓	-	-	✓	-
100 10 37***	56B-1	3.499	88.90	53.34	53.98	77.80	13.72	12.45	34.32	114.00	11.00	-	850000	35.00	✓	✓	-	-	✓	-
100 10 39***	64B-1	3.999	101.60	60.96	63.50	90.10	15.24	13.72	39.40	130.00	13.00	-	1120000	60.00	✓	✓	-	-	✓	-
100 10 41***	72B-1	4.499	114.30	68.58	72.39	103.60	17.27	16.00	44.50	147.00	14.00	-	1400000	80.00	✓	✓	-	-	✓	-



link no. 4



link no. 107



link no. 11/58



link no. 26



link no. 12



link no. 30

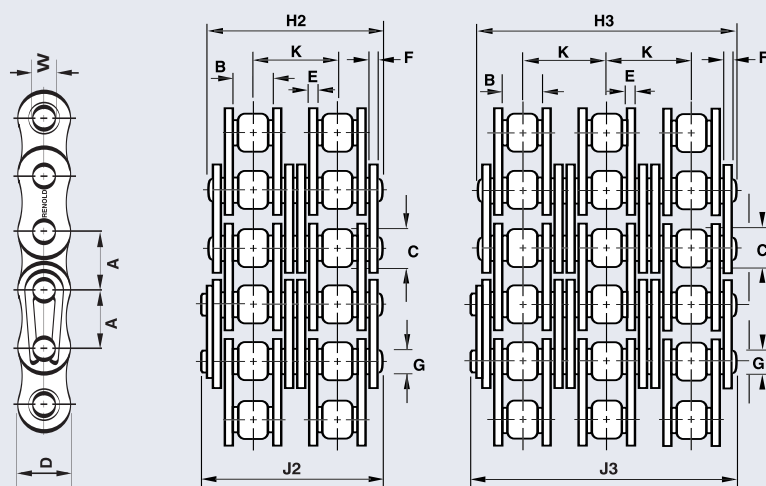

link no. 4



link no. 26



link no. 107



link no. 12



link no. 11/58



link no. 30

A&S BS Duplex Transmission Chain

Chain

Technical Details (mm)

Connecting Links

Renold Chain No	ISO No	Pitch	Pitch	Inside	Roller	Plate	Plate	Plate	Pin	Pin	Con	Trans	ISO606	Weight kg/m	No	No	No	No	No	No
		Inch	mm	Width Min	Dia Max	Height Max	Width Inner Max	Width Outer Max	Dia Max	Len Max	Link Extra Max	Pitch Norm	Tensile Strength Min (N) ‡		4	107	26	30	11/58	12
		A	A	B	C	D	E	F	G	H2	J	K								
100 00 04	-	0.236	6.00	2.80	4.00	5.00	0.57	0.57	1.85	12.50	2.90	5.50	-	0.24	✓	✓	✓	✓	-	-
100 00 07	05B-2	0.315	8.00	3.00	5.00	7.10	0.73	0.73	2.31	14.30	3.10	5.64	7800	0.36	✓	✓	✓	✓	✓	-
100 00 16	06B-2	0.375	9.525	5.72	6.35	8.20	1.25	1.00	3.28	23.80	3.30	10.24	16900	0.78	✓	✓	✓	✓	-	✓
100 00 32**	08B-2	0.500	12.70	7.75	8.51	11.80	1.50	1.50	4.45	31.00	3.30	13.92	31100	1.35	✓	✓	✓	-	✓	✓
100 00 41**	10B-2	0.625	15.875	9.65	10.16	14.70	1.50	1.50	5.08	36.20	4.10	16.59	44500	1.85	✓	✓	✓	✓	✓	✓
100 00 51**	12B-2	0.750	19.05	11.68	12.07	16.10	1.76	1.76	5.72	42.20	4.60	19.46	57800	2.50	✓	✓	✓	✓	✓	✓
100 00 69**	16B-2	1.000	25.40	17.02	15.88	21.00	4.00	3.00	8.28	68.00	5.40	31.88	106000	5.40	✓	✓	✓	✓	✓	✓
100 00 76	20B-2	1.250	31.75	19.56	19.05	26.40	4.40	3.50	10.19	79.70	6.10	36.45	170000	7.20	✓	✓	✓	✓	✓	✓
100 00 80	24B-2	1.500	38.10	25.40	25.40	33.40	5.90	5.00	14.63	101.00	6.60	48.36	280000	13.50	✓	✓	-	✓	✓	✓
100 06 11	28B-2	1.750	44.45	30.99	27.94	37.00	7.62	6.35	15.90	124.00	7.40	59.56	360000	16.50	✓	✓	-	-	✓	✓
100 06 18	32B-2	2.000	50.80	30.99	29.21	42.20	7.11	6.35	17.81	126.00	7.90	58.55	450000	21.00	✓	✓	-	-	✓	✓
100 06 21	40B-2	2.500	63.50	38.10	39.37	52.90	8.64	8.10	22.89	154.00	10.00	72.29	630000	32.00	✓	✓	-	-	✓	✓
100 10 35***	48B-2	2.999	76.20	45.72	48.26	63.80	12.19	10.16	29.24	190.00	10.00	91.21	1000000	50.00	✓	✓	-	-	✓	-
100 10 38***	56B-2	3.4999	88.90	53.34	53.98	77.80	13.72	12.45	34.32	221.00	11.00	106.60	1600000	70.00	✓	✓	-	-	✓	-
100 10 40***	64B-2	3.999	101.60	60.96	63.50	90.10	15.24	13.72	39.40	250.00	13.00	119.89	2000000	120.00	✓	✓	-	-	✓	-

A&S BS Triplex Transmission Chain

Chain

Technical Details (mm)

Connecting Links

Renold Chain No	ISO No	Pitch	Pitch	Inside	Roller	Plate	Plate	Plate	Pin	Pin	Con	Trans	ISO606	Weight kg/m	No	No	No	No	No	No
		Inch	mm	Width Min	Dia Max	Height Max	Width Inner Max	Width Outer Max	Dia Max	Len Max	Link Extra Max	Pitch Norm	Tensile Strength Min (N) ‡		4	7	26	30	11/58	12
		A	A	B	C	D	E	F	G	H3	J	K								
100 00 08	05B-3	0.315	8.00	3.00	5.00	7.10	0.73	0.73	2.31	19.90	3.10	5.64	11100	0.54	✓	✓	✓	✓	✓	-
100 00 17*	06B-3	0.375	9.525	5.72	6.35	8.20	1.25	1.00	3.28	34.00	3.30	10.24	24900	1.18	✓	✓	✓	✓	-	✓
100 00 33	08B-3	0.500	12.70	7.75	8.51	11.80	1.50	1.50	4.45	44.90	3.90	13.92	44500	2.00	✓	✓	✓	✓	✓	✓
100 00 42	10B-3	0.625	15.875	9.65	10.16	14.70	1.50	1.50	5.08	52.80	4.10	16.59	66700	2.80	✓	✓	✓	✓	✓	✓
100 00 52	12B-3	0.750	19.05	11.68	12.07	16.10	1.76	1.76	5.72	60.9	4.60	19.46	86700	3.80	✓	✓	✓	✓	✓	✓
100 00 70	16B-3	1.000	25.40	17.02	15.88	21.00	4.00	3.00	8.28	99.90	5.40	31.88	160000	8.00	✓	✓	✓	✓	✓	✓
100 00 77	20B-3	1.250	31.75	19.56	19.05	26.40	4.40	3.50	10.19	116.00	6.10	36.45	250000	11.00	✓	✓	✓	✓	✓	✓
100 00 81	24B-3	1.500	38.10	25.40	25.40	33.40	5.90	5.00	14.63	150.00	6.60	48.36	425000	21.00	✓	✓	-	✓	✓	✓
100 06 16	28B-3	1.750	44.45	30.99	27.94	37.00	7.62	6.35	15.90	184.00	7.40	59.56	530000	25.00	✓	✓	-	-	✓	✓
100 06 19	32B-3	2.000	50.80	30.99	29.21	42.20	7.11	6.35	17.81	184.00	7.90	58.55	670000	27.95	✓	✓	-	-	✓	✓

* Only with straight plates ** Straight side plates available *** Chains to BS 228 : 1984

Small and Large Pitch European (BS) Chain

ISO 606

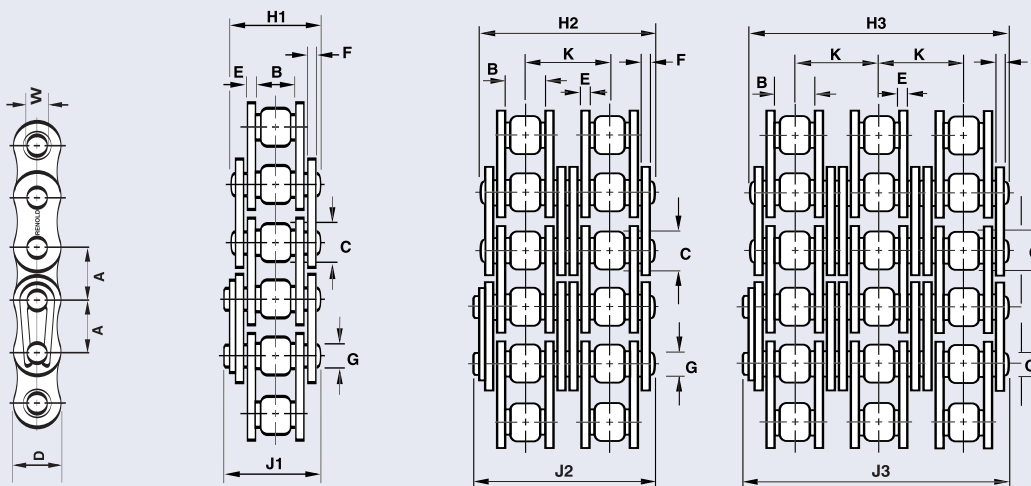

Chain Technical Details (mm) Connecting Links

Renold Chain No	ISO No	Pitch Inch	Pitch mm	Inside Width Min	Roller Dia Max	Plate Height Max	Plate Width Inner Max	Plate Width Outer Max	Pin Dia Max	Pin Len Max	Con Link Extra Max	Trans Pitch Nom	ISO606 Tensile Strength Min (N) ‡	Weight kg/m	No 4	No 107	No 11	No 26	No 12	No 30
															A	A	B	C	D	E

Simplex

1141	-	0.16	4.00	2.70	2.50	4.10	0.57	0.57	1.65	6.8	1.2	-	1800	0.07	✓	✓	✓	-	-	-
1151	03	0.20	5.00	2.50	3.20	4.10	0.57	0.57	1.49	7.4	2.5	-	2200	0.08	✓	✓	-	✓	-	✓
1161	04	0.24	6.00	2.80	4.00	5.00	0.57	0.57	1.85	7.4	2.9	-	3000	0.12	✓	✓	-	✓	-	✓
110500	05B-1	0.32	8.00	3.00	5.00	7.11	0.73	0.73	2.31	8.6	3.1	-	4400	0.18	✓	✓	-	✓	-	✓
110037	06B-1	0.38	9.53	3.94	6.35	8.26	1.30	1.04	3.28	10.9	1.3	-	8900	0.34	✓	✓	-	✓	-	✓
110147	28B-1	1.75	44.45	30.99	27.94	37.08	7.62	6.35	15.90	64.2	6.8	-	200000	9.35	✓	✓	-	✓	✓	-
110166	32B-1	2.00	50.80	30.99	29.21	42.29	7.11	6.35	17.81	63.4	8.0	-	250000	10.10	✓	✓	✓	-	✓	-
110206	40B-1	2.50	63.50	39.3	39.37	52.96	8.13	8.13	22.89	78.2	9.5	-	355000	16.50	✓	✓	✓	-	✓	-
180709	-	3.00	76.20	45.72	48.26	66.04	12.19	10.16	29.24	99.1	10.5	-	560000	25.80	✓	✓	✓	-	-	-
180781	-	3.50	88.90	53.34	53.98	80.52	13.72	12.70	34.30	114.6	11.7	-	778435	35.20	✓	✓	✓	-	-	-
110325	-	4.00	101.60	60.96	63.50	90.17	15.24	13.72	39.40	130.9	13.0	-	711800	49.30	✓	✓	-	-	-	-

Duplex

														H2							
114500	05B-2	0.32	8.00	3.00	5.00	7.11	0.73	0.73	2.31	14.3	3.1	5.64	7800	0.33	✓	✓	-	✓	-	✓	
114147	28B-2	1.75	44.45	30.99	27.94	37.08	7.62	6.35	15.90	123.7	6.8	59.56	360000	18.60	✓	✓	✓	-	✓	-	
114166	32B-2	2.00	50.80	30.99	29.21	42.29	7.11	6.35	17.81	126.0	7.9	58.55	450000	20.10	✓	✓	✓	-	✓	-	
114206	40B-2	2.50	63.50	39.3	39.37	52.96	8.13	8.13	22.89	154.9	10.2	72.29	630000	32.80	✓	✓	✓	-	✓	-	
180721	-	3.00	76.20	45.72	48.26	66.04	12.19	10.16	29.24	190.4	10.5	91.21	1000000	51.00	✓	✓	✓	-	-	-	
180760	-	3.50	88.90	53.34	53.98	80.52	12.45	13.72	34.30	221.2	11.7	106.60	1557000	69.70	✓	✓	✓	✓	-	-	
114325	-	4.00	101.60	60.96	63.50	90.17	15.24	13.72	39.40	250.8	13.0	119.90	1423420	97.50	✓	✓	-	-	-	-	

Triplex

														H3							
116500	05B-3	0.315	8.00	3.00	5.00	7.10	0.73	0.73	2.31	19.9	3.1	5.64	13200	0.52	✓	✓	-	✓	-	✓	
116147	28B-3	1.75	44.45	30.99	27.94	37.08	7.62	6.35	15.90	184.3	7.4	59.56	530000	28.00	✓	✓	✓	-	✓	-	
116166	32B-3	2.00	50.80	30.99	29.21	42.29	7.11	6.35	17.81	184.5	7.9	58.55	670000	30.00	✓	✓	✓	-	✓	-	
116206	40B-3	2.50	63.50	38.10	39.37	52.96	8.64	8.13	22.89	227.2	10.2	72.29	950000	48.90	✓	✓	✓	-	✓	-	
180739	-	3.00	76.20	45.72	48.26	66.04	12.19	10.16	29.24	281.6	10.5	91.21	1500000	76.20	✓	✓	✓	-	-	-	

‡ RENOLD CHAIN FAR EXCEEDS THE ISO606 MINIMUM TENSILE STRENGTH REQUIREMENT, BUT RENOLD DO NOT CONSIDER THAT THIS FIGURE PROVIDES A USEFUL INDICATOR TO THE KEY CHAIN PERFORMANCE AREAS OF WEAR AND FATIGUE.



No.4



No.107



No.11



No.26



No.12

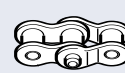

No.30

BS Simplex Chain - ISO 606

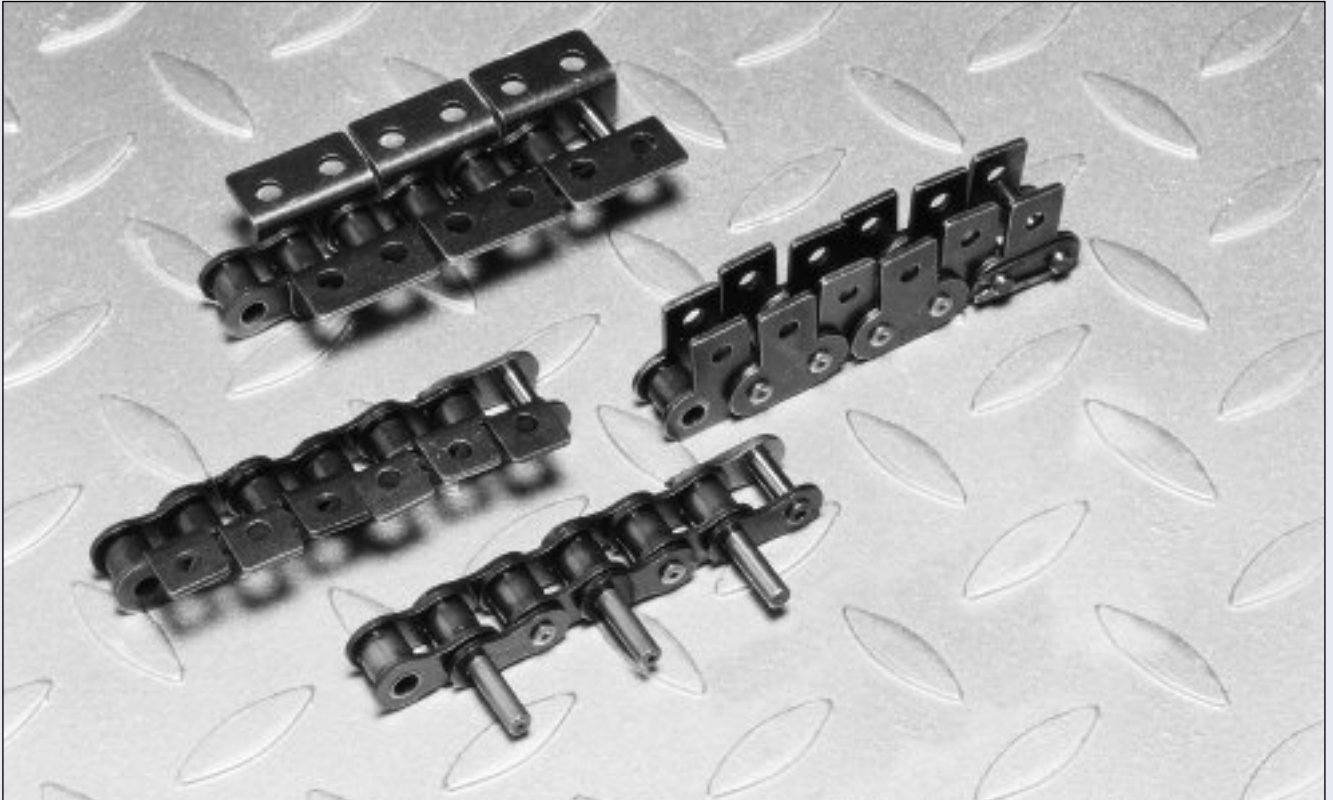

1

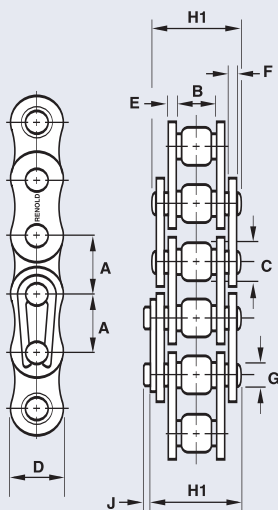

Renold standard power transmission chain can be adapted for conveying duties by the fitment of attachments shown on these pages. The attachments can be assembled on one or both sides of the chain at any desired pitch spacing.

- Note:
1. K2 attachments cannot be assembled on adjacent inner and outer links on the same side of the chain.
 2. M1 attachments cannot be assembled next to a No. 30 (Cranked link double) joint.

Bearing pins with an extension on one side of the chain can be built into chain at any desired pitch spacing and afford a simple means by which attachments or tubular staybars may be secured to chain. The pins for BS/DIN series chain are grooved for standard external type circlips to BS 3673 Part 2 (not supplied) so that, if required, attachments may be retained endwise or can be supplied as a standard straight extended pin.

Joints



No. 4
Inner link



No. 26
Connecting link-spring clip



No. 107
Outer link

Base Chain BS Simplex

Chain Technical Details

Renold Chain No	ISO No	Pitch Inch	Pitch mm	Inside Width Min	Roller Dia Max	Plate Height Max	Plate Width Inner Max	Plate Width Outer Max	Pin Dia Max	Pin Len Max	Con Link Extra Max	ISO 606 Tensile Strength F_B Newtons Min	Weight kg/m
		A	A	B	C	D	E	F	G	H1	J		
110046	08B-1	0.50	12.7	7.75	8.51	11.81	1.55	1.55	4.45	17.0	3.9	17800	0.70
110056	10B-1	0.625	15.875	9.65	10.16	14.73	1.55	1.55	5.08	19.6	4.1	22200	0.92
110066	12B-1	0.75	19.05	11.68	12.07	16.13	1.8	1.8	5.72	22.7	4.6	28900	1.20
110088	16B-1	1.00	25.4	17.02	15.88	21.08	4.12	3.1	8.28	36.1	5.4	60000	2.80
110106	20B-1	1.25	31.75	19.56	19.05	26.42	4.62	3.61	10.19	43.2	6.1	95000	3.85
110127	24B-1	1.50	38.10	25.40	25.40	33.40	6.10	5.08	14.63	53.4	6.6	160000	7.45

Standard K1 Attachments

ISO 606

1

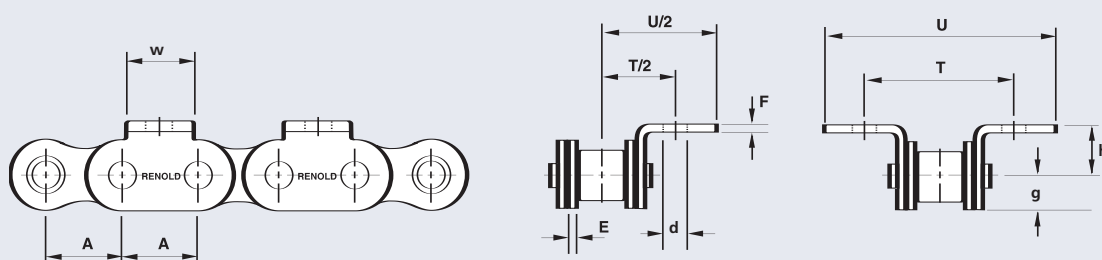

Renold Standard K1 Attachments

ISO No	Renold Chain No	Pitch	Pitch	E	F	w	h	d	g	T	U
		Inch	mm								
08B	110046	0.50	12.7	1.57	1.57	11.56	8.89	4.19	6.8	23.8	37.92
10B	110056	0.625	15.875	1.57	1.57	12.83	10.16	4.98	6.8	31.75	44.45
12B	110066	0.75	19.05	1.83	1.83	16.64	13.49	7.14	8.02	38.1	59.66
16B	110088	1.0	25.4	4.06	3.1	24.32	15.24	6.68	10.27	47.63	74.45
20B	110106	1.25	31.75	4.62	3.61	25.59	19.84	8.08	12.58	63.5	93.62

ISO Standard K1 Attachments

ISO No	Renold Chain No	Pitch	Pitch	E	F	w	h	d	g	T	U
		Inch	mm								
04	1161	0.236	6.0	0.57	0.57	5.8	4.5	2.3	2.5	11.2	17.6
05B	110500	0.315	8.0	0.73	0.73	7.8	5.3	2.3	3.4	13.5	21.5
06B	110038*	0.375	9.525	1.25	1.0	8.0	6.7	3.3	4.1	19.6	28.5
08B	110046	0.5	12.7	1.51	1.51	11.0	8.9	4.3	5.9	25.4	41.7
10B	110056	0.625	15.875	1.51	1.51	14.0	10.3	5.3	6.8	31.8	49.6
12B	110066	0.75	19.05	1.76	1.76	18.0	13.5	6.6	8.1	38.1	52.7
16B	110088	1.0	25.40	3.7	3.0	24.0	15.9	6.6	10.5	50.8	85.6
20B	110106	1.25	31.75	4.4	3.5	30.0	19.9	8.4	13.2	63.5	101.0
24B	110127	1.5	38.1	5.4	5.0	36.0	28.0	10.5	16.7	88.0	124.7

* STRAIGHT PLATE

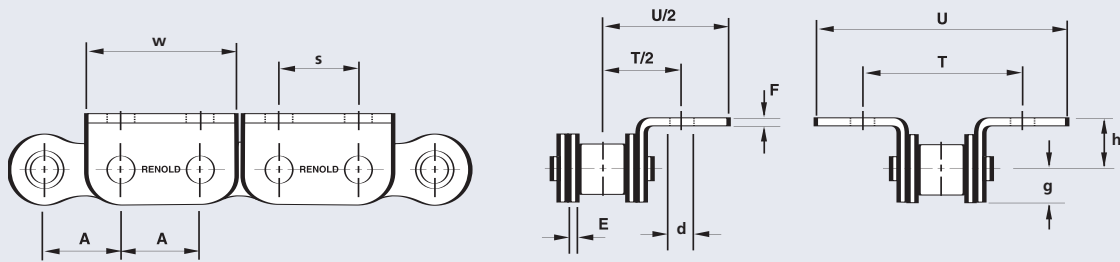
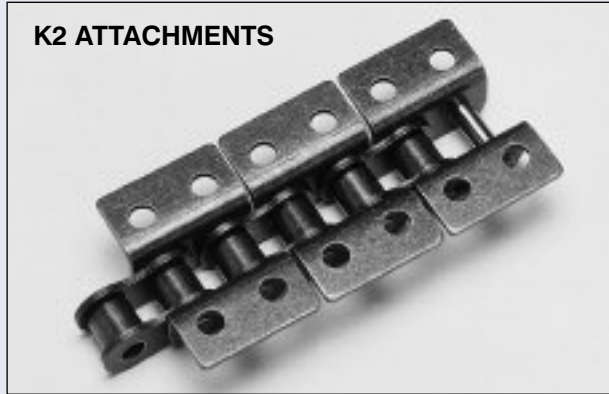

Renold Standard K2 Attachments

ISO No	Renold Chain No	Pitch	Pitch	E	F	h	d	g	w	s	T	U
		Inch	mm									
08B	110046	0.50	12.7	1.57	1.57	9.89	4.85	6.8	24.5	12.7	25.4	40.46
10B	110056	0.625	15.875	1.57	1.57	10.16	4.98	6.8	29.97	15.875	31.75	45.57
12B	110066	0.75	19.05	1.83	1.83	11.43	5.54	8.02	35.48	19.05	34.93	51.13
16B	110088	1.0	25.4	4.06	3.1	15.875	8.08	10.27	45.91	25.4	57.15	78.26
20B	110106	1.25	31.72	4.62	3.61	19.84	8.08	12.58	58.1	31.75	63.5	93.62

ISO Standard K2 Attachments

ISO No	Renold Chain No	Pitch	Pitch	E	F	h	d	g	w	s	T	U
		Inch	mm									
04	1161		6.0	0.57	0.57	4.5	2.3	2.5	11.1	6.0	11.2	17.6
05B	110500		8.0	0.73	0.73	5.3	2.3	3.4	14.8	8.0	13.5	21.5
06B	110038*	0.375	9.525	1.25	1.0	6.7	3.3	4.1	17.6	9.5	19.6	28.5
08B	110046	0.5	12.7	1.51	1.51	8.9	4.3	5.9	24.4	12.7	25.4	41.7
10B	110056	0.625	15.875	1.51	1.51	10.3	5.3	6.8	29.9	15.9	31.8	49.6
12B	110066	0.75	19.05	1.76	1.76	13.5	6.6	8.1	35.4	19.0	38.1	48.8
16B	110088	1.0	25.4	3.7	3.0	15.9	6.6	10.5	46.2	26.4	50.8	85.6
20B	110106	1.25	31.75	4.4	3.5	19.9	8.4	13.2	57.0	31.7	63.5	101.0
24B	110127	1.5	38.1	5.4	5.0	28.0	10.5	16.7	71.5	38.1	88.0	124.7

* STRAIGHT PLATE

Standard M1 Attachments

ISO 606

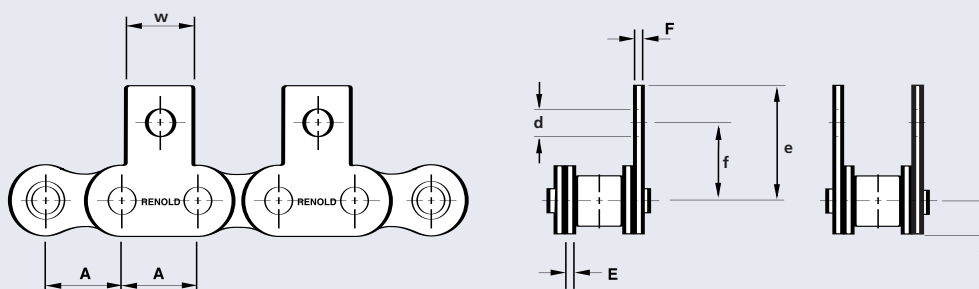

Renold Standard M1 Attachments

ISO No	Renold Chain No	Pitch	Pitch	E	F	w	e	f	d	g
		Inch	mm							
08B	110046	0.50	12.7	1.57	1.57	11.56	19.00	12.7	4.19	6.8
10B	110056	0.625	15.875	1.57	1.57	12.83	22.54	15.875	4.98	6.8
12B	110066	0.75	19.05	1.83	1.83	16.64	31.98	22.23	7.14	8.02
16B	110088	1.0	25.4	4.06	3.1	24.32	34.13	23.8	6.73	10.27
20B	110106	1.25	31.75	4.62	3.61	25.59	46.02	31.75	8.2	12.58

ISO Standard M1 Attachments

ISO No	Renold Chain No	Pitch	Pitch	E	F	w	e	f	d	g
		Inch	mm							
04	1161	-	6.0	0.57	0.57	5.8	10.0	6.8	2.3	2.5
05B	11050	-	8.0	0.73	0.73	7.8	11.9	8.6	2.3	3.4
06B	110038*	0.375	9.525	1.25	1.0	8.0	14.5	10.1	3.3	4.1
08B	110046	0.50	12.7	1.51	1.51	11.0	20.8	13.0	4.3	5.9
10B	110056	0.625	15.875	1.51	1.51	14.0	24.9	16.5	5.3	6.8
12B	110066	0.75	19.05	1.76	1.76	18.0	28.2	21.0	6.6	8.1
16B	110088	1.0	25.4	3.7	3.0	24.0	39.7	23.0	6.6	10.5
20B	110106	1.25	31.75	4.4	3.5	30.0	47.5	30.5	8.4	13.2
24B	110127	1.5	38.1	5.4	5.0	36.0	61.5	42.7	10.5	16.7

* STRAIGHT PLATE

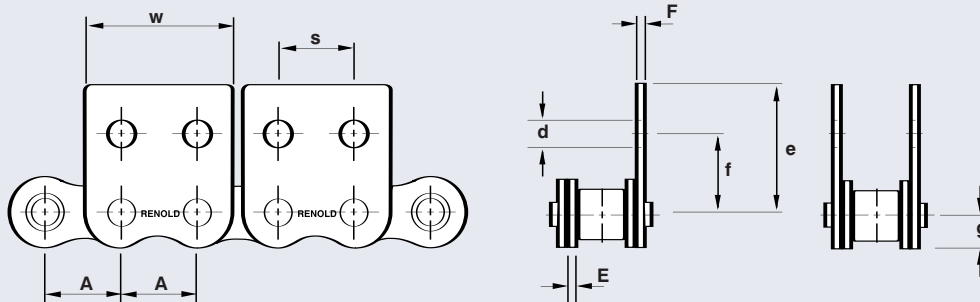
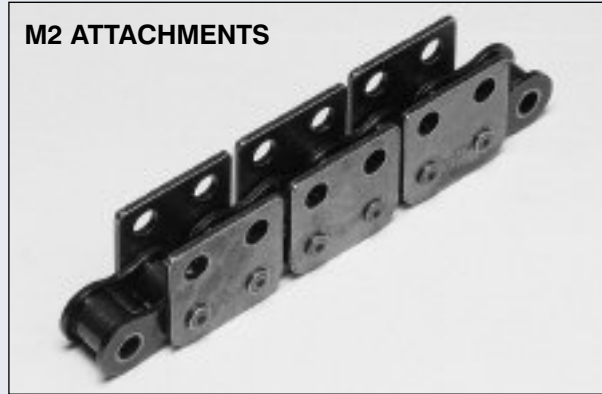

ISO Standard M2 Attachments

ISO No	Renold Chain No	Pitch	Pitch	E	F	e	f	d	g	w	s
		Inch	mm								
04	1161	-	6.0	0.57	0.57	10.0	6.8	2.3	2.5	11.1	6.0
05B	110500	-	8.0	0.73	0.73	11.9	8.6	2.3	3.4	14.8	8.0
06B	110038*	0.375	9.525	1.25	1.0	14.5	10.1	3.3	4.1	17.6	9.5
08B	110046	0.50	12.7	1.51	1.51	20.8	13.0	4.3	5.9	24.4	12.7
10B	110056	0.625	15.875	1.51	1.51	24.9	16.5	5.3	6.8	29.9	15.9
12B	110066	0.75	19.05	1.76	1.76	28.2	21.0	6.6	8.1	35.4	19.0
16B	110088	1.0	25.4	3.7	3.0	39.7	23.0	6.6	10.5	46.2	25.4
20B	110106	1.25	31.75	4.4	3.5	47.5	30.5	8.4	13.2	57.0	31.7
24B	110127	1.5	38.1	5.4	5.0	61.5	42.7	10.5	16.7	71.5	38.1

* STRAIGHT PLATE

K1 & K2 Attachments

ISO 1275

Renold BS Double Pitch Standard K1 Attachments

1

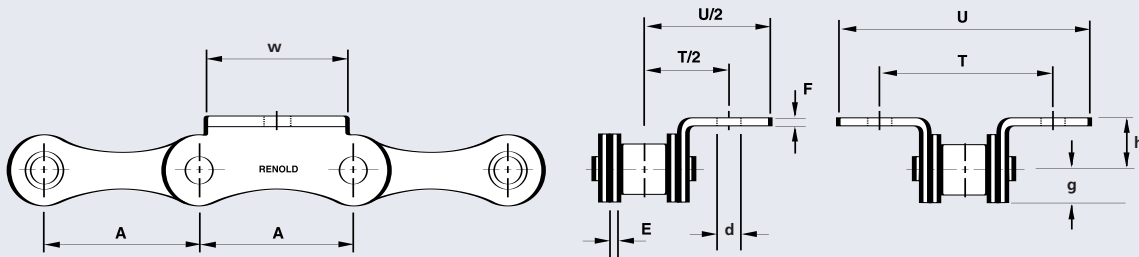

ISO No	Renold Chain No	Pitch Inch	Pitch mm	Pitch		E	F	w	h	d	g	T	U
				A	A								
208B	113083 *	1.0	25.4	1.51	1.51	23.8	8.5	4.3	5.8	27.6	42.5		
210B	113103 *	1.25	31.75	1.51	1.51	25.4	10.5	5.3	7.4	31.6	48.5		
212B	113123 *	1.50	38.1	1.76	1.76	20.0	12.2	6.4	8.2	35.2	54.8		
216B	113168	2.0	50.8	3.7	3.0	40.0	17.0	8.4	10.3	58.0	83.8		
220B	113203	2.5	63.5	4.4	4.1	40.0	21.0	10.5	11.3	69.0	98.7		
224B	113243	3.0	76.2	5.4	5.0	70.0	28.0	10.5	16.7	88.0	124.7		

* STRAIGHT PLATE

Renold BS Double Pitch Standard K2 Attachments

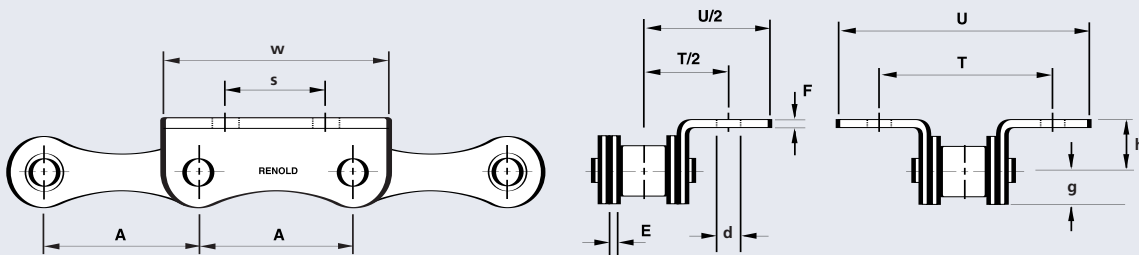

ISO No	Renold Chain No	Pitch Inch	Pitch mm	Pitch		h	d	g	w	s	T	U
				A	A							
208B	113083 *	1.0	25.4	1.51	1.51	8.5	4.3	5.8	37.1	12.7	27.6	42.5
210B	113103 *	1.25	31.75	1.51	1.51	10.5	5.3	7.4	46.7	15.8	31.6	48.5
212B	113123 *	1.5	38.1	1.76	1.76	12.2	6.4	8.2	54.4	19.0	35.2	54.8
216B	113168	2.0	50.8	3.7	3.0	17.0	8.4	10.3	71.3	25.4	58.0	83.8
220B	113203	2.5	63.5	4.4	4.1	21.0	10.5	11.3	86.5	31.7	69.0	98.7

* STRAIGHT PLATE

Renold BS Double Pitch Standard M1 Attachments

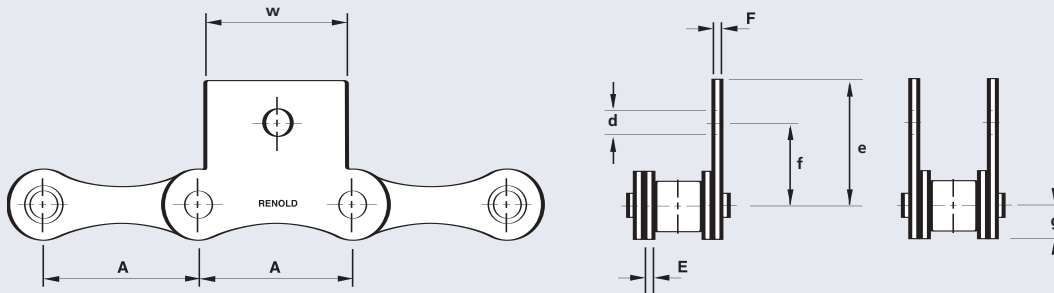

ISO No	Renold Chain No	Pitch Inch	Pitch mm		E	F	w	e	f	d	g
			A	A							
208B	113083 *	1.0	25.4	1.51	1.51	23.8	20.8	13.7	4.3	5.8	
210B	113103 *	1.25	31.85	1.51	1.51	25.4	24.9	16.5	5.3	7.4	
212B	113123 *	1.5	38.1	1.73	1.73	20.0	28.3	18.5	6.4	8.2	
216B	113168	2.0	50.8	3.7	3.0	40.0	40.0	27.4	8.4	10.3	
220B	113203	2.5	63.5	4.4	4.1	40.0	48.7	33.0	10.5	11.3	
224B	113243	3.0	76.2	5.4	5.0	70.0	61.5	42.7	10.5	16.7	

* STRAIGHT PLATE

Renold BS Double Pitch Standard M2 Attachments

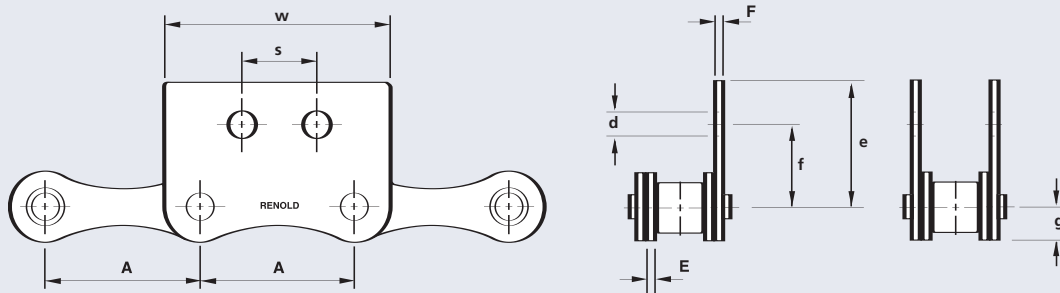

ISO No	Renold Chain No	Pitch Inch	Pitch mm		E	F	e	f	d	g	w	s
			A	A								
208B	113083 *	1.0	25.4	1.51	1.51	20.8	13.7	4.3	5.8	37.1	12.7	
210B	113103 *	1.25	31.75	1.51	1.51	24.9	16.5	5.3	7.4	46.7	15.8	
212B	113123 *	1.50	38.1	1.76	1.76	28.3	18.5	6.4	8.2	54.4	19.0	
216B	113168	2.0	50.8	3.7	3.0	40.0	27.4	8.4	10.3	71.3	25.4	
220B	113203	2.5	63.5	4.4	4.1	48.7	33.0	10.5	11.3	86.5	31.7	
224B	113243	3.0	76.2	5.4	5.0	61.5	42.7	10.5	16.7	-	38.1	

* STRAIGHT PLATE

European (BS) Standard Extended Bearing Pins

1

EXTENDED PINS WITH CIRCLIP GROOVE



Extended pin + circlip groove (type C)

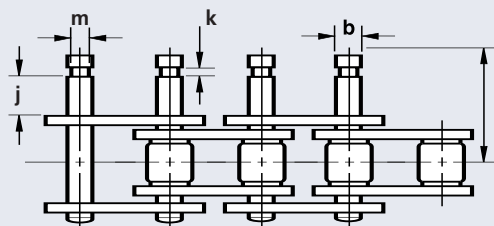

Extended Pins Type C

ISO No	Renold Chain No	Pitch Inch	Pitch mm	Pin dia.	Extension length to circlip groove (max)	Circlip groove Width (min)	Circlip groove Dia. (min)	Chain track from chain centre line (max)
	No	A	A	(max) b	(max) j	(min) k	(min) m	f
08B-1	110046	0.50	12.7	4.45	7.19	0.58	3.18	17.78
10B-1	110056	0.625	15.875	5.08	9.45	0.71	3.73	21.34
12B-1	110066	0.75	19.05	5.72	11.81	0.71	4.78	25.15
16B-1	110088	1.0	25.4	8.28	15.75	1.02	6.93	36.58

Unit Assemblies



No163
Outer link



No165
Connecting link-spring clip



No164
Outer link



No166
Connecting link-spring clip

STRAIGHT EXTENDED PINS



Straight extended pin (type D)

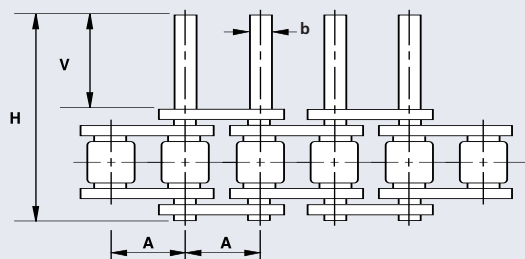

Extended Pins Type D ISO 606

ISO No	Renold Chain No	Pitch Inch	Pitch mm	Pin dia. ±0.01	Extension length ±0.25	Pin length (max)
	No	A	A	b	V	H
06B-1	110038*	0.375	9.525	3.28	11.3	23.8
08B-1	110046	0.50	12.7	4.45	14.8	31.0
10B-1	110056	0.625	15.875	5.08	17.6	36.2
12B-1	110066	0.75	19.05	5.72	20.7	42.4
16B-1	110088	1.0	25.4	8.28	33.3	68.0
20B-1	110106	1.25	31.75	10.19	38.3	79.7
24B-1	110127	1.5	38.1	14.63	50.3	101.8

Unit Assemblies



No 563
Outerlink



No 565
Connecting link - spring clip



No 564
Outerlink



No 566
Connecting link - spring clip

* STRAIGHT SIDE PLATES

Attachment Chain Connecting Links For Renold BS Simplex Roller Chain

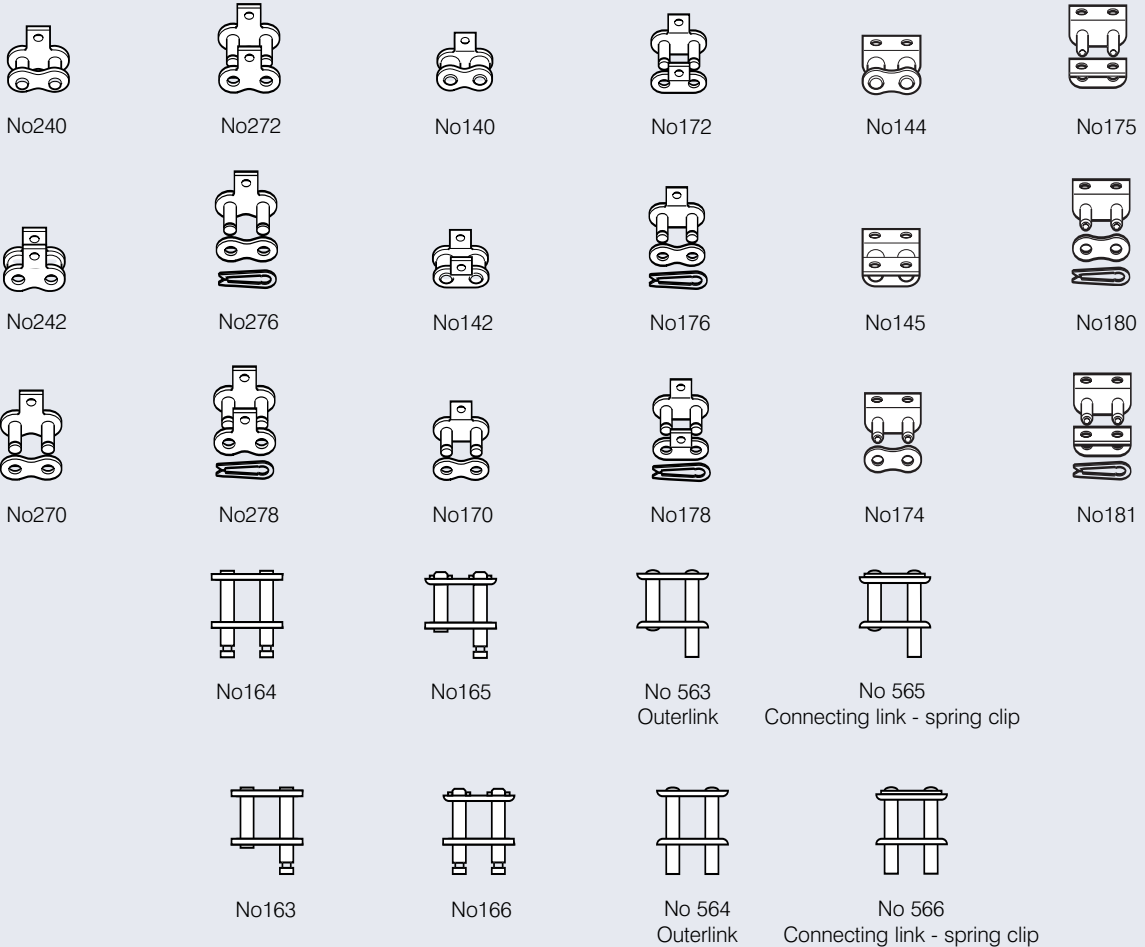

Special or Adapted Transmission Chain

In addition to our ranges of standard series chain we can also offer:

- Transmission Chain up to 300mm pitch and 450 tonnes breaking load.
- Standard Series Chain adapted to your unique needs with special attachments.
- Special Chain designed with integral attachments to meet individual requirements.

Renold Adapted Chain can be in the form of special plates, pin rollers, or blocks which can be designed, manufactured and assembled into chain of all pitch sizes.

Attachments can be made from normal materials, stainless steel or plastics.

We will be pleased to receive details of your requirements and evaluate them for strength, durability, price and despatch. They can be manufactured from your own designs or adapted from existing drawings.

The illustrations below show only a small selection of the wide range of variants and these chains have been used successfully in many branches of industry for the feeding, conveying and discharge of a variety of products.

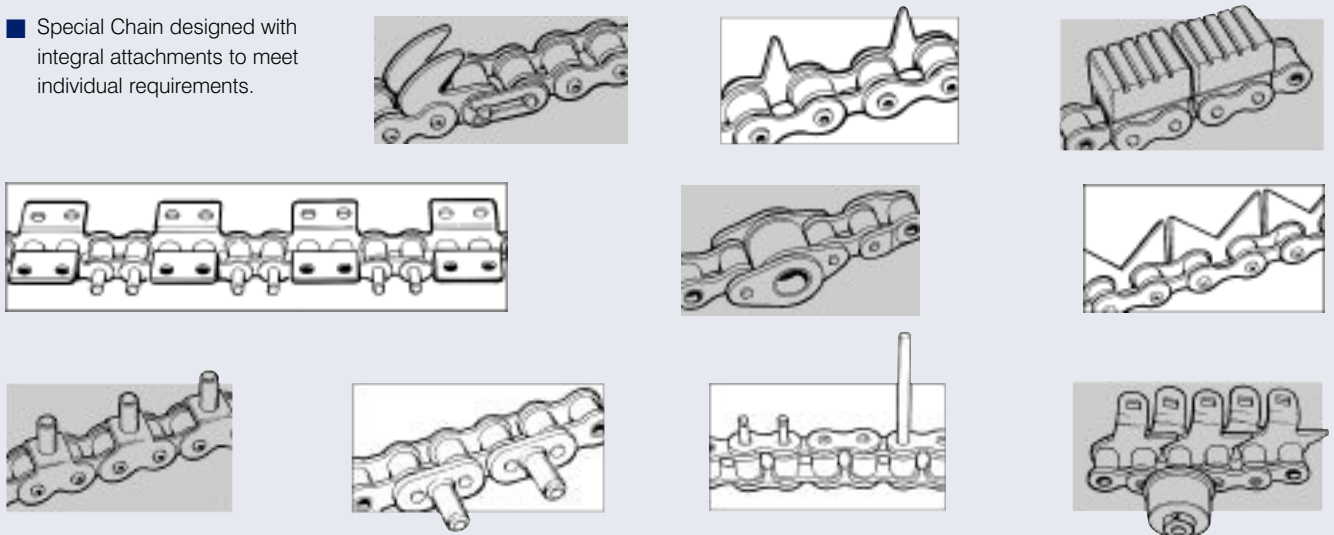

RENOLD Syno Nickel Plated Chain

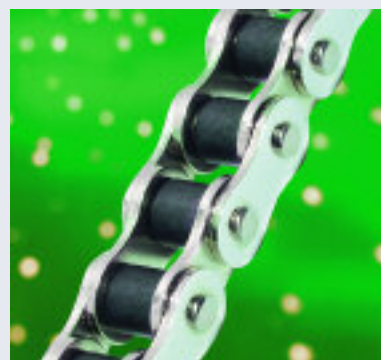

No need to relubricate this chain!

This dry-to-the-touch chain now includes more performance enhancing characteristics than ever before. Using the latest techniques, Renold have incorporated special surface treatment processes to improve the bonding of the nickel plating. This type of plating is not prone to chipping or peeling as some other plated chains are prone to doing.

The pin coating minimises friction, improving wear life and reducing vibration, while the FDA-approved coating on the roller and the USDA H1-approved lubricant within the chain make it ideal for food processing environments.

At a glance

- Dry-to-the-touch chain
- Never needs relubrication
- FDA-approved coating on rollers
- Nickel-plating on plates won't chip or peel
- Good resistance to corrosion
- USDA H1-approved lubricant inside chain when supplied
- Standard chain dimensions so can be exchanged "like for like"
- Will run on standard sprockets
- BS: 1/2" to 1 1/2" simplex and duplex (06B-1 to 24B-1 and 06B-2 to 24B-2)
- ANSI: 1/2" to 1 1/4" simplex and duplex (40-1 to 100-1 and 40-2 to 100-2)

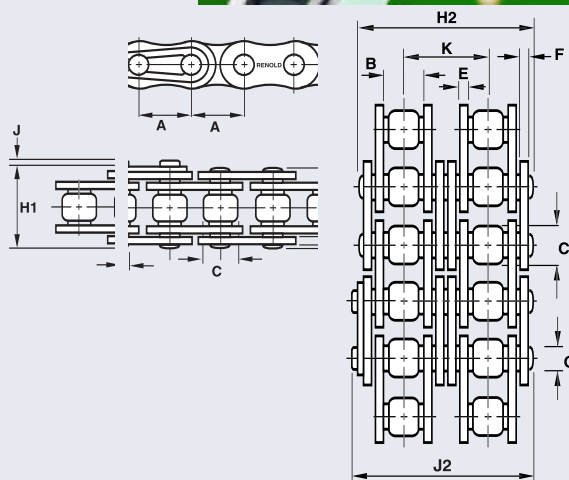

BS Standard Nickel Plated Chain - Simplex

Chain Technical Details (mm)

Connecting Links

Renold Chain No	ISO No	Pitch	Pitch	Inside	Roller	Plate	Plate	Plate	Pin	Pin	Con	Transverse	ISO	Weight	No	No	No	No	No	No
		Inch	mm	Width	Dia	Height	Width	Width	Dia	Len	Link	Pitch	Breaking Load		4	107	26	11	12	30
		A	A	B	C	D	E	F	G	H1	J		F _B in N Min							
110438	06B-1	0.375	9.525	5.72	6.35	8.2	1.25	1.00	3.28	12.5	1.1	-	8900	0.40	✓	✓	✓	-	-	✓
110446	08B-1	0.50	12.70	7.75	8.51	11.7	1.76	1.50	4.45	17.0	1.4	-	17800	0.73	✓	✓	✓	✓	-	✓
110456	10B-1	0.625	15.875	9.65	10.16	14.6	2.00	1.50	5.08	19.6	1.4	-	22200	1.01	✓	✓	✓	✓	-	✓
110466	12B-1	0.75	19.05	11.68	12.07	16.0	2.36	1.76	5.72	23.6	1.4	-	28900	1.30	✓	✓	✓	✓	-	✓
110488	16B-1	1.00	25.40	17.02	15.88	20.2	3.70	3.00	8.27	35.0	1.6	-	60000	2.72	✓	✓	✓	✓	✓	✓
111506	20B-1	1.25	31.75	19.56	19.05	25.3	4.40	3.50	10.17	41.4	2.1	-	95000	3.75	✓	✓	✓	✓	✓	✓
110527	24B-1	1.50	38.10	25.40	25.40	33.4	6.00	5.00	14.63	52.6	5.0	-	160000	7.35	✓	✓	-	✓	✓	✓

BS Standard Nickel Plated Chain - Duplex

Chain Technical Details (mm)

Connecting Links

Renold Chain No	ISO No	Pitch	Pitch	Inside	Roller	Plate	Plate	Plate	Pin	Pin	Con	Transverse	ISO	Weight	No	No	No	No	No	No
		Inch	mm	Width	Dia	Height	Width	Width	Dia	Len	Link	Pitch	Breaking Load		4	107	26	11	12	30
		A	A	B	C	D	E	F	G	H1	J	K	F _B in N Min							
114438	06B-2	0.375	9.525	5.72	6.35	8.2	1.25	1.00	3.28	23.0	1.1	10.24	16900	0.76	✓	✓	✓	-	-	✓
114446	08B-2	0.50	12.70	7.75	8.51	11.7	1.76	1.50	4.45	30.9	1.4	13.92	31100	1.40	✓	✓	✓	✓	-	✓
114456	10B-2	0.625	15.875	9.65	10.16	14.6	2.00	1.50	5.08	36.2	1.4	16.59	44500	1.93	✓	✓	✓	✓	-	✓
114466	12B-2	0.75	19.05	11.68	12.07	16.0	2.36	1.76	5.72	43.1	1.4	19.46	57800	2.47	✓	✓	✓	✓	-	✓
114488	16B-2	1.00	25.40	17.02	15.88	20.2	3.70	3.00	8.27	66.9	1.6	31.88	106000	5.08	✓	✓	✓	✓	✓	✓
114506	20B-2	1.25	31.75	19.56	19.05	25.3	4.40	3.50	10.17	77.9	2.1	36.45	170000	7.06	✓	✓	✓	✓	✓	✓
114527	24B-2	1.50	38.10	25.40	25.40	33.4	6.00	5.00	14.63	101.0	5.0	48.36	280000	14.55	✓	✓	-	✓	✓	✓



No.4



No.107



No.26



No.11



No.12



No.30

As a response to increasing demand for chain that provides good performance in clean environments where contamination is a potential risk, Renold has used its technical expertise to create Renold Syno Stainless Steel Chain, with superior features such as corrosion resistance, low maintenance and excellent performance.

Conventional lubricant serves a dual purpose, providing lubrication but also serving as a barrier to corrosion. However in biologically sensitive areas such as food processing applications, the requirement is for low maintenance (minimal lubrication) with excellent corrosion resistance. This makes Renold Syno Stainless Steel Chain the logical, practical choice.

The chain brings together the features and benefits of two Renold products; Syno low maintenance chain and Stainless steel chain. All based around the proven performance and unsurpassed wear life of every Renold chain, Renold Syno Stainless Steel Chain gives the best possible value for money.

It is suitable for use in such situations as food packaging and preparation, pharmaceuticals, canning and also textiles and clothing.

With these features, this is an unbeatable choice for the most unforgiving of environments. Another example of Renold technology and experience being put to the test and delivering results.

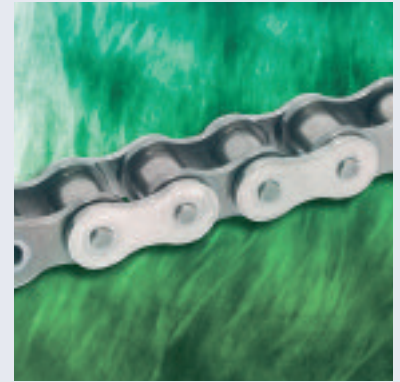

1

AT A GLANCE

- Lowest maintenance for clean environments.
- Excellent corrosion resistance.
- Chain has dry, grease-free surface.
- Excellent chain life with minimal maintenance.
- For use in temperatures up to 150°C.
- Attachments available.

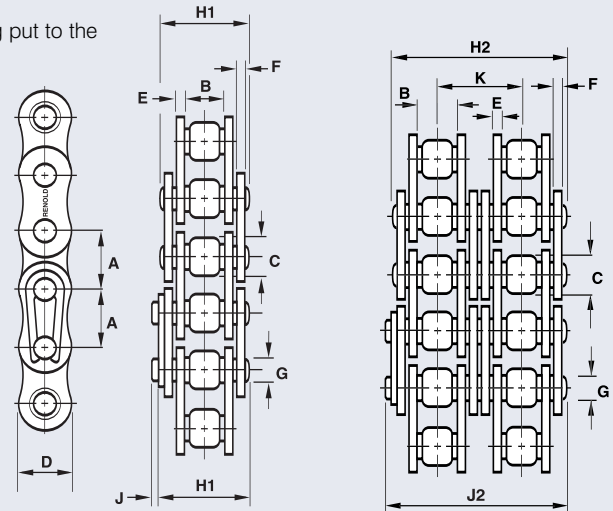

European (BS) - Simplex

Chain		Technical Details											Connecting Links					
Renold Chain No	ISO No	Pitch Inch	Pitch mm	Inside Width Min	Roller Dia Max	Plate Height Max	Plate Width Inner Max	Plate Width Outer Max	Pin Dia Max	Pin Len Max	Con Link Extra Max	Trans Pitch	Breaking Load F _B Newtons Min	Weight kg/m	No 4	No 107	No 26	No 11
		A	A	B	C	D	E	F	G	H1	J	K						
110746	08B-1	0.5	12.7	7.75	8.51	11.7	1.8	1.5	3.97	16.9	1.5	-	12000	0.7	✓	✓	✓	-
110756	10B-1	0.625	15.87	9.65	10.16	14.6	2.0	2.0	4.45	20.4	2.4	-	14700	1.1	✓	✓	-	✓
110766	12B-1	0.75	19.05	11.68	12.07	16.7	2.4	2.4	5.08	25.3	2.2	-	18640	1.5	✓	✓	-	✓
110788	16B-1	1.0	25.4	17.02	15.88	20.2	3.7	3.0	7.00	35.0	2.7	-	26500	2.5	✓	✓	-	✓

European (BS) - Duplex

Chain		Technical Details											Connecting Links					
Renold Chain No	ISO No	Pitch Inch	Pitch mm	Inside Width Min	Roller Dia Max	Plate Height Max	Plate Width Inner Max	Plate Width Outer Max	Pin Dia Max	Pin Len Max	Con Link Extra Max	Trans Pitch	Breaking Load F _B Newtons Min	Weight kg/m	No 4	No 107	No 26	No 11
		A	A	B	C	D	E	F	G	H1	J	K						
114746	08B-2	0.5	12.7	7.75	8.51	11.7	1.8	1.5	3.97	30.8	1.5	13.92	23430	1.35	✓	✓	✓	-
114756	10B-2	0.625	15.87	9.65	10.16	14.6	2.0	2.0	4.45	37.0	2.4	16.59	29430	1.98	✓	✓	-	✓
114766	12B-2	0.75	19.05	11.68	12.07	16.7	2.4	2.4	5.08	44.8	2.2	19.46	37280	2.5	✓	✓	-	✓
114788	16B-2	1.0	25.4	17.02	15.88	20.2	3.7	3.0	7.00	66.8	2.8	31.88	53000	4.8	✓	✓	-	✓



No. 4



No. 107



No. 26



No. 11

RENOLD Syno Polymer Bush Chain

For higher loads and more heavy-duty applications, the Renold Syno Polymer Bush range takes on the serious business of wear and fatigue resistance through the addition of a polymer sleeve between the pin and bush. This highly durable and wear resistant polymer – specifically developed for Renold – as well as a polymer roller that has been tested for impact resistance and load capabilities means that the chain can be operated without any lubrication. Available in 28B – 40B and ideal for applications where it is not possible or not advisable to lubricate a chain, Renold Syno Polymer Bush chain can be considered for:



1

- Outdoor or wash down environments
- Environments where lubrication may contaminate products
- Environments where lubrication may cause contaminants to stick to the chain and possibly get into bearing areas, seizing up the chain
- Car assembly plants or steel mills
- Forestry, saw mills or paper mills
- Textile plants
- Mixers

With a corrosion resistant surface treatment adding to the variety of applications it can cope with, Renold Syno Polymer Bush chain is a truly versatile product.

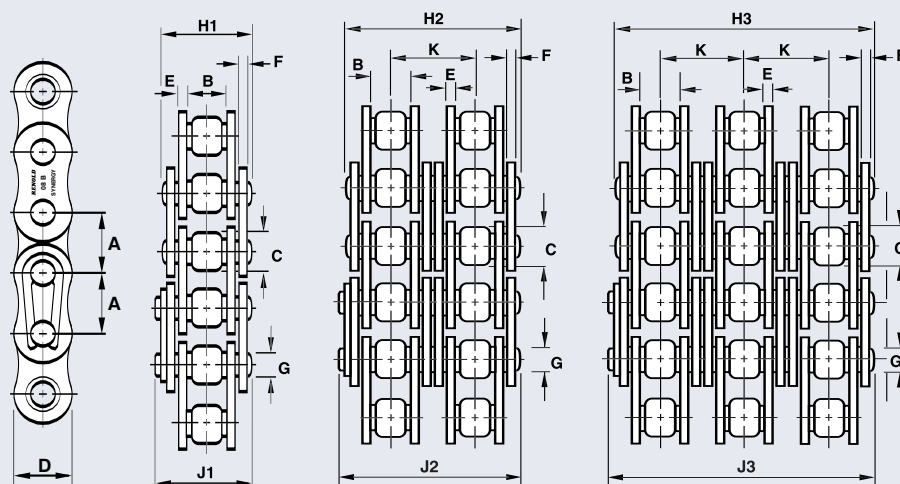

BS Standard Syno Polymer Bush

Chain Technical Details (mm)

Connecting Links

Renold Chain No	ISO No	Pitch Inch	Pitch mm	Inside Width Min	Roller Dia Max	Plate Height Max	Plate Width Inner Max	Plate Width Outer Max	Pin Dia Max	Pin Len Max	Con Link Extra Max	Transverse Pitch Nom	ISO Breaking Load F _b in N Min	Mass with polymer roller kg/m	No 11	No 107
		A	A	B	C	D	E	F	G	H1	J					
520147	28B-1	1.75	44.45	30.99	27.94	37.08	7.62	6.35	12.71	64.2	6.8	-	200000	8.1	✓	✓
520166	32B-1	2.0	50.8	30.99	29.21	42.29	7.11	6.35	14.29	63.4	8.0	-	250000	9.0	✓	✓
520206	40B-1	2.25	63.5	39.30	39.37	52.96	8.13	8.13	19.85	78.2	9.5	-	355000	14.3	✓	✓

BS Standard Syno Polymer Bush - Duplex

Chain Technical Details (mm)

Connecting Links

Renold Chain No	ISO No	Pitch Inch	Pitch mm	Inside Width Min	Roller Dia Max	Plate Height Max	Plate Width Inner Max	Plate Width Outer Max	Pin Dia Max	Pin Len Max	Con Link Extra Max	Transverse Pitch Nom	ISO Breaking Load F _b in N Min	Mass with polymer roller kg/m	No 11	No 107
		A	A	B	C	D	E	F	G	H1	J					
524147	28B-2	1.75	44.45	30.99	27.94	37.08	7.62	6.35	12.71	123.7	6.8	59.56	360000	16.0	✓	✓
524166	32B-2	2.0	50.8	30.99	29.21	42.29	7.11	6.35	14.29	122.0	8.0	58.55	450000	17.9	✓	✓
524206	40B-2	2.25	63.5	39.30	39.37	52.96	8.13	8.13	19.85	150.5	9.5	72.29	694000	28.4	✓	✓



No.107



No. 11/58

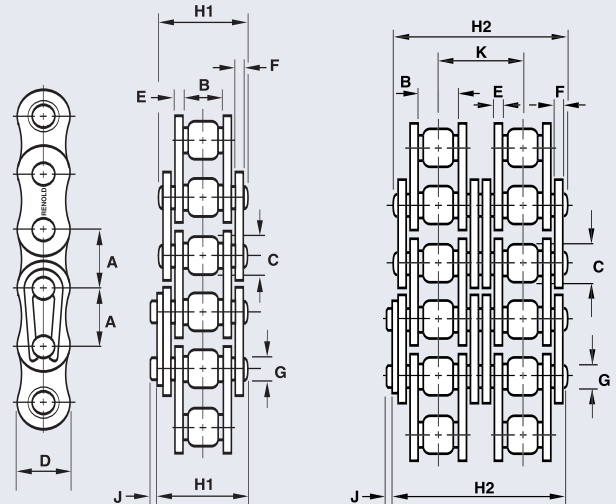

1

Renold roller chain is manufactured using Class 300 Series stainless steel specification. These chains are ideal for acidic or alkaline environments, or where the chain will be exposed to water, and for very high or very low temperature locations, -40° to +400°C where resistance to corrosion is a requirement.

Renold chain should be selected when resistance to chemical action is critical. Renold is manufactured using FDA approved material and is prelubricated with USDA H1 approved lubricant.

Renold BS Standard Stainless Steel Chain - Simplex

Renold Chain No	ISO No	Technical Details											Connecting Links					
		Pitch Inch	Pitch mm	Inside Width Min	Roller Dia Max	Plate Height Max	Plate Width Inner Max	Plate Width Outer Max	Pin Dia Max	Pin Len Max	Con Link Extra Max	Trans Pitch Nom	Breaking Load F_B Newtons # Min	Weight kg/m	No 4	No 107	No 26	No 11
		A	A	B	C	D	E	F	G	H1	J	K						
185302	06B-1	0.375	9.525	5.72	6.35	8.26	1.25	1.0	3.28	12.5	1.3	-	6850	0.41	✓	✓	✓	-
181707	08B-1	0.5	12.7	7.75	8.51	11.81	1.5	1.5	4.45	16.5	1.5	-	12000	0.7	✓	✓	✓	✓
180280	10B-1	0.625	15.875	9.65	10.16	14.73	1.5	1.5	5.08	18.8	1.3	-	14700	0.95	✓	✓	✓	✓
185634	12B-1	0.75	19.05	11.68	12.07	16.1	1.76	1.76	5.72	21.9	1.1	-	18640	1.25	✓	✓	✓	✓
187900	16B-1	1.0	25.4	17.02	15.88	21.08	3.7	3.0	8.28	34.9	2.2	-	43160	2.7	✓	✓	✓	✓

Renold BS Standard Stainless Steel Chain - Duplex

Renold Chain No	ISO No	Technical Details											Connecting Links					
		Pitch Inch	Pitch mm	Inside Width Min	Roller Dia Max	Plate Height Max	Plate Width Inner Max	Plate Width Outer Max	Pin Dia Max	Pin Len Max	Con Link Extra Max	Trans Pitch Nom	Breaking Load F_B Newtons # Min	Weight kg/m	No 4	No 107	No 26	No 11
		A	A	B	C	D	E	F	G	H2	J	K						
185122	06B-2	0.375	9.525	5.72	6.35	8.26	1.25	1.0	3.28	23.0	1.3	10.24	12150	0.78	✓	✓	✓	✓
185125	08B-2	0.5	12.7	7.75	8.51	11.81	1.5	1.5	4.45	30.4	1.5	13.92	23540	1.35	✓	✓	✓	✓
185126	10B-2	0.625	15.875	9.65	10.16	14.73	1.5	1.5	5.08	35.4	1.3	16.59	29400	1.85	✓	✓	✓	✓
185127	12B-2	0.75	19.05	11.68	12.07	16.1	1.76	1.76	5.72	41.4	1.1	19.46	37280	2.5	✓	✓	✓	✓
185128	16B-2	1.0	25.4	17.02	15.88	21.08	3.7	3.0	8.28	66.8	2.2	31.88	86320	5.4	✓	✓	✓	✓

These are minimum breaking loads. RENOLD does not consider breaking load to be a good indicator of performance, as it overlooks the principal factors of wear and fatigue.



No.4



No.107



No.26



No.11

RENOLD Sovereign BS Chain

Superior abrasion resistance ISO 606

The bearing pin on Renold Sovereign features a surface conditioning which, when combined with the strictly-controlled geometric features of the bush, takes the performance of Renold chain to new levels of endurance in harsh environments.

As a result, Renold Sovereign provides a greater resistance to wear in adverse conditions such as dirty, dusty and abrasive environments including applications such as brick manufacturing, roof tile production and processes involving ceramic or cement dust or debris.



1

Applications include:

- Agricultural machinery
- Brick manufacture
- Ceramics
- Cementitious environments
- Metal working
- Roof tile production

Product features and benefits include:

- Resilient, durable components
- Up to three times longer wear life than standard chain in harsh environments
- Up to two times longer wear life than low maintenance chain in harsh environments
- Reduced pin wear
- Suitable for high speed or heavy load applications
- Excellent reliability giving reduced maintenance costs
- Ideal for situations of irregular or restricted maintenance

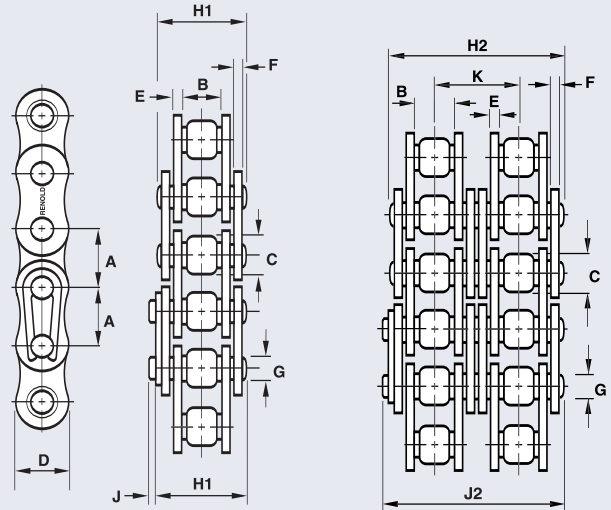

Renold Sovereign (BS) Standard Chain

Chain

Technical Details

Connecting Links

Renold Chain No	ISO No	Pitch Inch	Pitch mm	Inside Width Min	Roller Dia Max	Inner Plate Height Max	Plate Width Inner Max	Plate Width Outer Max	Pin Dia Max	Pin Len Max	Con Link Extra Max	Breaking Load F_B Newtons Min	Weight kg/m	No 4	No 12	No 26	No 30	No 107
Simplex										H1								
110846	08B-1	0.5	12.7	7.75	8.51	11.81	1.55	1.55	4.45	16.5	1.5	17800	0.70	✓	-	✓	✓	✓
110856	10B-1	0.625	15.875	9.65	10.16	14.73	1.55	1.55	5.08	18.8	1.3	22200	0.92	✓	-	✓	✓	✓
110866	12B-1	0.75	19.05	11.68	12.07	16.13	1.80	1.80	5.72	21.9	1.1	28900	1.20	✓	-	✓	✓	✓
110888	16B-1	1.0	25.4	17.02	15.88	21.08	4.12	3.10	8.28	34.9	2.2	60000	2.80	✓	✓	✓	-	✓
Duplex										H2								
114846	08B-2	0.5	12.7	7.75	8.51	11.81	1.55	1.55	4.45	30.4	1.5	31100	1.38	✓	-	✓	✓	✓
114856	10B-2	0.625	15.875	9.65	10.16	14.73	1.55	1.55	5.08	35.4	1.3	44500	1.80	✓	-	✓	✓	✓
114866	12B-2	0.75	19.05	11.68	12.07	16.13	1.80	1.80	5.72	41.4	1.1	57800	2.40	✓	-	✓	✓	✓
114888	16B-2	1.0	25.4	17.02	15.88	21.08	4.12	3.10	8.28	66.8	2.2	106000	5.50	✓	✓	✓	-	✓
Triplex										H3								
116846	08B-3	0.5	12.7	7.75	8.51	11.81	1.55	1.55	4.45	44.3	1.5	44500	2.06	✓	-	✓	✓	✓
116856	10B-3	0.625	15.875	9.65	10.16	14.73	1.55	1.55	5.08	52.0	1.3	66700	2.54	✓	-	✓	✓	✓
116866	12B-3	0.75	19.05	11.68	12.07	16.13	1.80	1.80	5.72	60.9	1.1	86700	3.60	✓	-	✓	✓	✓

F_B = AXIAL BREAKING FORCE



No. 4



No. 12



No. 26

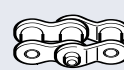

No. 30



No. 107

Renold Hydro-Service® chains are treated with a mechanical zinc plating process with additional coatings applied for extra corrosion protection. The corrosion resistance of this coating in many wet, humid, saltwater or other moisture-related applications is far superior to standard nickel or zinc plating. Unlike some products treated in a similar way for corrosion resistance, Renold Hydro-Service® chain is hexavalent chrome-free, ensuring that it is safe and also environmentally friendly. This coating can be applied to standard or adapted, BS or ANSI chain. All components of the Hydro-Service® chain are treated prior to assembly in order to achieve full coverage and protection to all vital surfaces, not just those visible external surfaces. This helps to improve chain wear life and protect against corrosion-related pin and bush failures. Unlike nickel or zinc platings, the Hydro-Service® treatment will not chip or peel. This extremely durable coating will continue to provide exceptional protection where other treatments fail.



1

Product features include:

- Excellent corrosion resistance
- Hexavalent chrome-free
- More than 30 times the corrosion protection compared with conventional surface treatments
- No hydrogen embrittlement failures
- More economical than stainless steel chain
- Same strength and working load values as standard carbon steel chain

Potential applications:

- Sea water environments
- Meat and poultry processing plants
- Vegetable processing plants
- Seafood processing plants
- Beverage plants
- Washdown equipment
- Outdoor applications

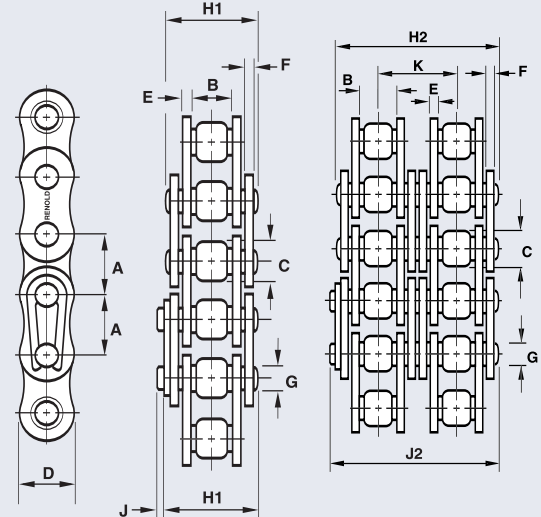

Hydro-Service BS Base Chain Data - Simplex

Chain		Technical Details											Connecting Links							
Renold Chain No	ISO No	Pitch Inch	Pitch mm	Inside Width Min	Roller Dia Max	Plate Height Max	Plate Width Inner Max	Plate Width Outer Max	Pin Dia Max	Pin Len Max	Con Link Extra Max	Trans Pitch	Breaking Load F _B Newtons Min	Weight kg/m	No 4	No 107	No 11	No 12	No 26	No 30
		A	A	B	C	D	E	F	G	H1	J	K								
530038	06B-1	0.375	9.525	5.72	6.35	8.26	1.3	1.04	3.28	13.5	3.3	-	8900	0.39	✓	✓	-	-	✓	✓
530046	08B-1	0.5	12.7	7.75	8.51	11.81	1.55	1.55	4.45	17.0	3.9	-	17800	0.7	✓	✓	-	-	✓	✓
530056	10B-1	0.625	15.88	9.65	10.16	14.73	1.55	1.55	5.08	18.8	1.3	-	22200	0.92	✓	✓	-	-	✓	✓
530066	12B-1	0.75	19.05	11.68	12.07	16.13	1.8	1.8	5.72	21.9	1.1	-	28900	1.2	✓	✓	-	-	✓	✓
530088	16B-1	1.0	25.4	17.02	15.88	21.08	4.12	3.10	8.28	36.1	5.4	-	60000	2.8	✓	✓	-	✓	✓	-
530106	20B-1	1.25	31.75	19.56	19.05	26.42	4.62	3.61	10.19	43.2	6.1	-	95000	3.85	✓	✓	-	✓	✓	-
530127	24B-1	1.5	38.1	25.4	25.4	33.4	6.1	5.08	14.63	53.4	6.6	-	160000	7.45	✓	✓	✓	✓	-	-

Hydro-Service BS Base Chain Data - Duplex

Chain		Technical Details											Connecting Links							
Renold Chain No	ISO No	Pitch Inch	Pitch mm	Inside Width Min	Roller Dia Max	Plate Height Max	Plate Width Inner Max	Plate Width Outer Max	Pin Dia Max	Pin Len Max	Con Link Extra Max	Trans Pitch	Breaking Load F _B Newtons Min	Weight kg/m	No 4	No 107	No 11	No 12	No 26	No 30
		A	A	B	C	D	E	F	G	H2	J	K								
534038	06B-2	0.375	9.525	5.72	6.35	8.26	1.3	1.04	3.28	23.0	1.3	10.24	16900	0.74	✓	✓	-	-	✓	✓
534046	08B-2	0.5	12.7	7.75	8.51	11.81	1.55	1.55	4.45	30.4	1.5	13.92	31100	1.38	✓	✓	-	-	✓	✓
534056	10B-2	0.625	15.875	9.65	10.16	14.73	1.55	1.55	5.08	35.4	1.3	16.59	44500	1.8	✓	✓	-	-	✓	✓
534066	12B-2	0.75	19.05	11.68	12.07	16.13	1.8	1.8	5.72	41.4	1.1	19.46	57800	2.4	✓	✓	-	-	✓	✓
534088	16B-2	1.0	25.4	17.02	15.88	21.08	4.12	3.1	8.28	68.0	5.4	31.88	106000	5.5	✓	✓	-	✓	✓	-
534106	20B-2	1.25	31.75	19.56	19.05	26.42	4.62	3.61	10.19	76.7	2.7	36.45	170000	7.8	✓	✓	-	✓	✓	-
534127	24B-2	1.5	38.1	25.4	25.4	33.4	6.1	5.08	14.63	101.3	6.8	48.36	280000	14.8	✓	✓	✓	✓	-	-



No. 4



No. 107



No. 11



No. 12



No. 26



No. 30

Transmission Straight Side Plate

ISO 606

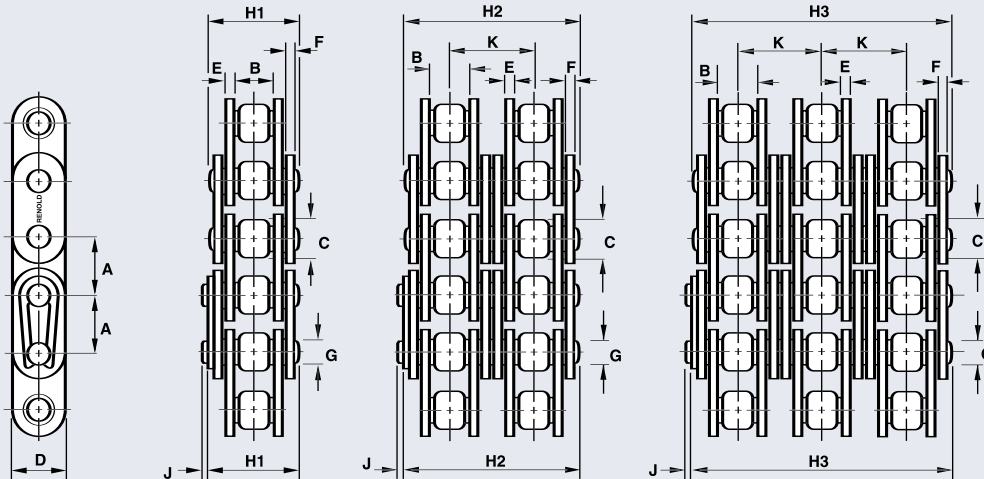

Straight Side Plate - Simplex

Chain

Technical Details

Connecting Links

Renold Chain No	ISO No	Pitch Inch	Pitch mm	Inside Width Min	Roller Dia Max	Plate Height Max	Plate Width Inner Max	Plate Width Outer Max	Pin Dia Max	Pin Len Max	Con Link Extra Max	Trans Pitch Nom	F _B Newtons Min	Weight kg/m	No	No	No	No	No	No
															4	107	26	30	11/58	12
		A	A	B	C	D	E	F	G	H1	J	K								
110047	08B-1	0.5	12.7	7.75	8.51	11.81	1.55	1.55	4.45	17.0	3.9	-	17800	0.7	✓	✓	✓	✓	✓	✓
110057	10B-1	0.625	15.88	9.65	10.16	14.7	1.55	1.55	5.08	19.6	4.1	-	22200	0.92	✓	✓	✓	✓	✓	✓
110067	12B-1	0.75	19.05	11.68	12.07	15.93	1.8	1.8	5.72	22.7	4.6	-	28900	1.2	✓	✓	✓	✓	✓	✓
110080	16B-1	1.0	25.4	17.02	15.88	24.06	4.12	3.1	8.28	36.1	5.4	-	60000	3.45	✓	✓	✓	-	-	-
110120	24B-1	1.5	38.1	25.4	25.4	35.75	6.1	5.08	14.63	53.4	6.6	-	160000	7.45	✓	✓	✓	-	-	-
110140	28B-1	1.75	44.45	30.99	27.94	41.68	7.62	6.35	15.9	65.1	7.4	-	200000	9.35	✓	✓	✓	-	-	-
110160	32B-1	2.0	50.8	30.99	29.21	47.6	7.11	6.35	17.81	67.4	7.9	-	250000	10.1	✓	✓	✓	-	-	-

Straight Side Plate - Duplex

Chain

Technical Details

Connecting Links

Renold Chain No	ISO No	Pitch Inch	Pitch mm	Inside Width Min	Roller Dia Max	Plate Height Max	Plate Width Inner Max	Plate Width Outer Max	Pin Dia Max	Pin Len Max	Con Link Extra Max	Trans Pitch Nom	F _B Newtons Min	Weight kg/m	No	No	No	No	No	No
															4	107	26	30	11/58	12
		A	A	B	C	D	E	F	G	H2	J	K								
114047	08B-2	0.5	12.7	7.75	8.51	11.81	1.55	1.55	4.45	31.0	3.9	13.92	31000	1.38	✓	✓	✓	✓	✓	✓
114057	10B-2	0.625	15.88	9.65	10.16	14.7	1.55	1.55	5.08	36.2	4.1	16.59	44500	1.8	✓	✓	✓	✓	✓	✓
114067	12B-2	0.75	19.05	11.68	12.07	15.93	1.8	1.8	5.72	42.2	4.6	19.46	57800	2.4	✓	✓	✓	✓	✓	✓
114080	16B-2	1.0	25.4	17.02	15.88	24.0	4.12	3.1	8.28	68.0	5.4	31.88	106000	5.5	✓	✓	✓	-	-	-
114120	24B-2	1.5	38.1	25.4	25.4	35.75	6.1	5.08	14.63	101.8	6.6	48.36	280000	14.8	✓	✓	✓	-	-	-

Straight Side Plate - Triplex

Chain

Technical Details

Connecting Links

Renold Chain No	ISO No	Pitch Inch	Pitch mm	Inside Width Min	Roller Dia Max	Plate Height Max	Plate Width Inner Max	Plate Width Outer Max	Pin Dia Max	Pin Len Max	Con Link Extra Max	Trans Pitch Nom	F _B Newtons Min	Weight kg/m	No	No	No	No	No	No
															4	107	26	30	11/58	12
		A	A	B	C	D	E	F	G	H3	J	K								
116048	08B-3	0.5	12.7	7.75	8.51	11.81	1.55	1.55	4.45	44.9	3.9	13.92	445000	2.06	✓	✓	✓	✓	✓	✓
116080	16B-3	1.0	25.4	17.02	15.88	24.06	4.12	3.1	8.28	99.9	5.4	31.88	160000	10.12	✓	✓	✓	-	-	-

F_B = AXIAL BREAKING FORCE



No. 4



No. 107



No. 26



No. 30



No. 11/58



No. 12

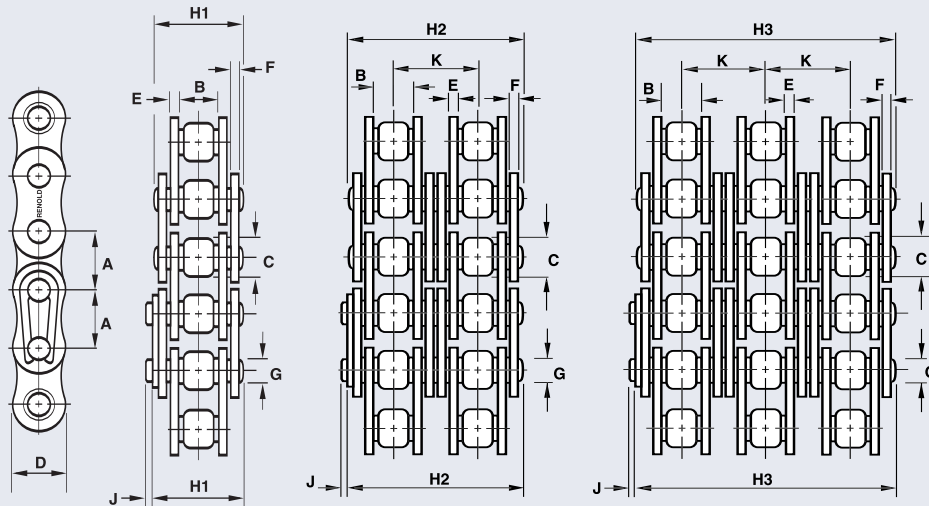

1

Chain

Technical Details

Connecting Links

Renold Chain No	ISO No	Pitch Inch	Pitch mm	Inside Width Min	Roller Dia Max	Plate Height Max	Plate Width Inner Max	Plate Width Outer Max	Pin Dia Max	Pin Len Max	Con Link Extra Max	Trans Pitch Max	F _B Newtons Min	Weight kg/m	No	No	No	No	No	No																
															4	107	26	11	12	30																
		A	A	B	C	D	E	F	G	H1	J	K																								
Nickel Plated BS Standard - Simplex																																				
550038	06B-1	0.375	9.525	5.72	6.35	8.26	1.30	1.04	3.28	13.5	3.3	-	8900	0.39	✓	✓	✓	-	-	✓																
550046	08B-1	0.5	12.7	7.75	8.51	11.81	1.55	1.55	4.45	17.0	3.9	-	17800	0.70	✓	✓	✓	-	-	✓																
550056	10B-1	0.625	15.87	9.65	10.16	14.73	1.55	1.55	5.08	18.8	4.1	-	22200	0.92	✓	✓	✓	-	-	✓																
550066	12B-1	0.75	19.05	11.68	12.07	16.13	1.80	1.80	5.72	22.7	4.6	-	28900	1.20	✓	✓	✓	-	-	✓																
550088	16B-1	1.0	25.4	17.02	15.88	21.08	4.12	3.10	8.28	36.1	5.4	-	60000	2.80	✓	✓	✓	-	✓	-																
550127	24B-1	1.5	38.1	25.40	25.40	33.40	6.10	5.08	14.63	53.4	6.6	-	160000	7.45	✓	✓	-	✓	✓	-																
550147	28B-1	1.75	44.45	30.99	27.94	37.08	7.62	6.35	15.90	65.1	7.4	-	200000	9.35	✓	✓	-	✓	✓	-																
550166	32B-1	2.0	50.8	30.99	29.21	42.29	7.11	6.35	17.81	67.4	7.9	-	250000	10.10	✓	✓	-	✓	✓	-																
Nickel Plated BS Standard - Duplex																																				
554066	12B-2	0.75	19.05	11.68	12.07	16.13	1.80	1.80	5.72	42.2	4.6	19.46	57800	2.40	✓	✓	✓	-	-	✓																
554088	16B-2	1.0	25.4	17.02	15.88	21.08	4.12	3.10	8.28	68	5.4	31.88	106000	5.50	✓	✓	✓	-	✓	-																
Nickel Plated BS Standard - Triplex																																				
556088	16B-3	1.0	25.4	17.02	15.88	21.08	4.12	3.10	8.28	99.9	5.4	31.88	160000	8.15	✓	✓	✓	-	✓	-																

F_B = AXIAL BREAKING FORCE



No.4



No.107



No.26



No.11



No.12



No.30

Cranked Link Chain

1

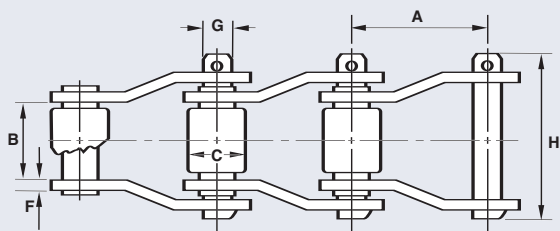

Cranked Link Chain

Chain Technical Details

Renold Chain No	Pitch Inch	Pitch mm	Roller Dia	Plate Thickness	Plate Height	Pin Dia	Pin Length	Breaking Load*	Weight kg/m
	A	A	C	F	A	G	H		
IS2065	2.000	50.800	28.575	7.938	39.243	15.062	73.819	65,000	11.307
JS882	2.069	52.553	22.225	6.350	28.575	11.113	62.706	26,000	5.356
JS1031	3.075	78.105	31.750	7.938	38.100	15.875	83.344	48,000	10.861
JS3075	3.075	78.105	31.750	9.525	42.863	16.434	89.694	75,000	13.390
JS3011	3.067	77.902	41.275	9.525	57.150	19.050	89.694	110,000	19.490
JS3514	3.500	88.900	44.450	12.700	57.150	22.250	102.394	140,000	25.739
JS4014	4.063	103.200	44.450	12.700	57.150	22.250	111.919	140,000	22.912
JS4106	4.063	103.200	44.450	12.700	57.150	22.250	111.919	70,000	23.207
JS1245A	4.073	103.454	45.244	14.288	60.325	23.800	121.444	170,000	27.822
IS4121	4.090	103.886	47.625	14.288	69.850	25.349	118.269	210,000	35.707
IS4522	4.500	114.300	57.150	14.288	76.200	27.915	125.413	220,000	37.195
JS5031	5.000	127.000	63.500	15.875	88.900	31.750	146.844	280,000	53.561
1605AAA	5.000	127.000	63.500	19.050	88.900	34.925	161.925	350,000	64.720
JS6042	6.000	152.400	76.200	19.050	101.600	38.100	174.625	420,000	69.034

F_B = AXIAL BREAKING FORCE

* Average breaking load in lbs



No. 59

Renold Hollow Pin Chain is designed for long wear life in light conveyor applications. The hollow pin has a versatile design capability and provides for the fitment of a wide variety of attachments.

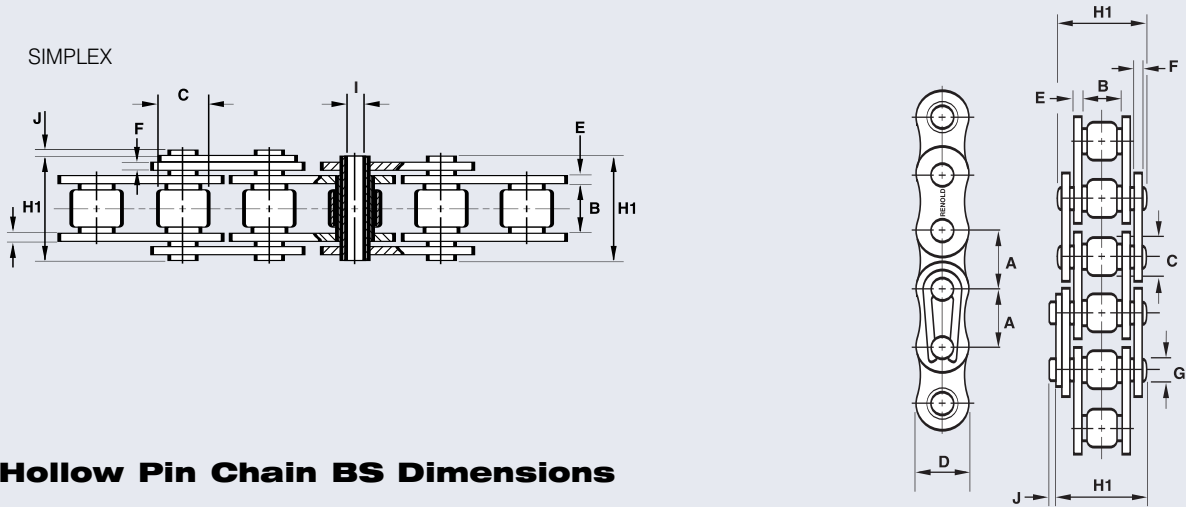

1

Hollow Pin Chain BS Dimensions

Chain Technical Details Connecting Links

Renold Chain No	Pitch Inch	Pitch mm	Inside Width Min	Roller Dia Max	Plate Height Max	Plate Width Inner Max	Plate Width Outer Max	Pin Bore Min	Pin Length Max	Con Link Extra Max	Breaking Load FB Newtons Min	Weight kg/m	No 4	No 26
	A	A	B	C	D	E	F	W	H1	J				
Simplex - Bush Chain														
187120	0.5	12.7	7.75	8.51	12.1	1.51	1.51	4.5	16.5	1.1	12000	0.66	✓	✓
Simplex - Stainless Steel Chain														
187111	0.5	12.7	7.75	8.51	12.5	1.51	1.51	4.58	16.5	1.1	10500	0.61	✓	✓
Simplex - Bush Roller Chain														
187124	1.0	25.4	12.7	15.88	23.0	3.0	3.0	6.0	30.8	1.3	70000	2.22	✓	✓
187123	1.0	25.4	12.7	15.88	23.0	3.0	3.0	7.05	30.8	1.3	40000	2.2	✓	✓
187127	1.968	50.0	10	30.0	27.5	3.0	3.0	8.2	26.0	4.0	60000	2.2	✓	✓
187128	2.0	50.8	10	30.0	25.5	3.0	3.0	8.2	26.0	4.0	60000	2.1	✓	✓
187129	3.937	100.0	10	30.0	25.5	3.0	3.0	8.2	26.0	4.0	60000	1.5	✓	✓



No. 4



No. 26

BS Double Pitch Chain & Bush Chain

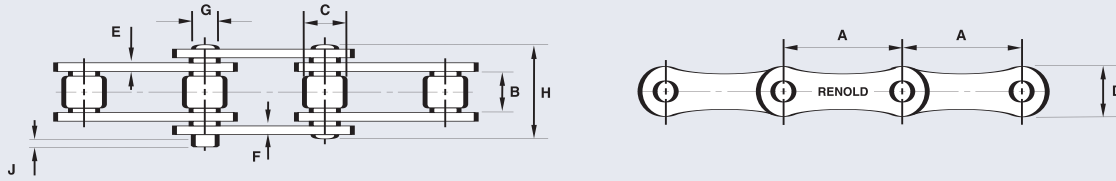

Transmission Simplex Double Pitch Chain ISO 1275

Chain		Technical Details													Connecting Links					
Renold Chain No	ISO No	Pitch Inch	Pitch mm	Inside Width Min	Roller Dia Max	Plate Height Max	Plate Width Inner Max	Plate Width Outer Max	Pin Dia Max	Pin Len Max	Con Link Extra Max	Trans Pitch	F _B Newtons Min	Weight kg/m	No 4	No 107	No 11	No 58	No 12	No 30
		A	A	B	C	D	E	F	G	H	J	K								
113083*	208B	1.0	25.4	7.75	8.51	11.43	1.55	1.55	4.45	16.6	3.9	-	19000	0.53	✓	✓	✓	-	-	✓
113103*	210B	1.25	31.75	9.65	10.16	13.72	1.55	1.55	5.08	19.6	4.1	-	23000	0.66	✓	✓	✓	-	-	✓
113123*	212B	1.50	38.1	11.68	12.07	15.88	1.8	1.8	5.72	22.7	4.6	-	30500	0.90	✓	✓	✓	-	-	✓
113168	216B	2.0	50.8	17.02	15.88	20.83	4.12	3.1	8.28	36.1	5.4	-	67000	1.80	✓	✓	✓	-	-	✓
113203	220B	2.50	63.5	19.56	19.05	24.64	4.12	3.61	10.19	43.2	6.1	-	98070	2.45	✓	✓	✓	-	✓	-
113243	224B	3.0	76.2	25.4	25.4	33.53	6.1	5.08	14.63	53.4	6.6	-	166700	4.80	✓	✓	✓	-	✓	-
113323	232B	4.0	101.6	30.99	29.21	40.13	7.11	6.35	17.81	67.4	7.9	-	255000	5.95	✓	✓	✓	-	-	-

F_B = AXIAL BREAKING FORCE * STRAIGHT SIDEPLATE



No.4

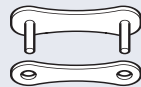

No.107



No.11/58

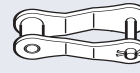

No.12

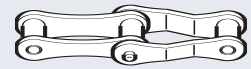

No.30

ISO 606 B Series

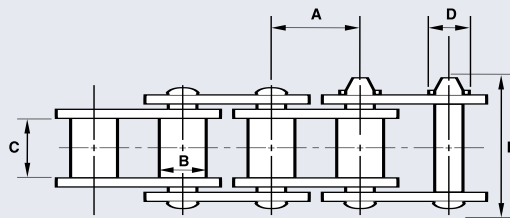

Chain		Technical Details											Connecting Links						
Renold Chain No	Pitch Inch	Pitch mm	Bush Dia Max	Inside Width Min	Plate Height Max	Inner Plate Thickness Max	Outer Plate Thickness Max	Pin Dia Extra Max	Pin Length Max	Con Link Min	Trans Pitch	Tensile Strength	Weight kg/m	No 4	No 107	No 11	No 12	No 26	No 30
	A	A	B	C				D	E										

Bush Chain Simplex (Standard Chain Without Rollers)

120038	0.375	9.53	4.71	5.72	8.26	1.30	1.04	3.28	13.5	3.3	-	11000	0.3	✓	✓	-	-	✓	✓
120046	0.50	12.70	6.35	7.75	11.81	1.55	1.55	4.45	17.0	3.9	-	19000	0.55	✓	✓	-	-	✓	✓
120056	0.625	15.88	7.25	9.65	14.73	1.55	1.55	5.08	19.6	4.1	-	23000	0.68	✓	✓	-	-	✓	✓
120066	0.75	19.05	8.64	11.68	16.13	1.80	1.80	5.72	22.7	4.6	-	30500	0.88	✓	✓	-	-	✓	✓
120088	1.00	25.40	11.44	17.02	21.08	4.12	3.10	8.28	36.1	5.4	-	67000	2.22	✓	✓	-	✓	✓	-
120106	1.25	31.75	13.37	19.56	26.42	4.62	3.61	10.19	43.2	6.1	-	98070	3.07	✓	✓	-	✓	✓	-
120127	1.50	38.10	18.42	25.40	33.40	6.10	5.08	14.63	53.4	6.6	-	166700	5.49	✓	✓	✓	✓	-	-
120147	1.75	44.45	20.35	30.99	37.08	7.62	6.35	15.90	65.1	7.4	-	200000	6.55	✓	✓	✓	✓	-	-
120166	2.00	50.80	22.15	30.99	42.29	7.11	6.35	17.81	67.4	7.9	-	255000	8.17	✓	✓	✓	✓	-	-
120206	2.50	63.50	29.98	38.10	52.96	8.64	8.13	22.89	82.6	10.2	-	372700	13.42	✓	✓	✓	✓	-	-
120245	3.00	76.20	37.34	45.72	63.88	12.19	10.16	29.24	99.1	10.5	-	400350	21.36	✓	✓	-	-	-	-

Bush Chain Duplex

124281	3.50	88.90	43.21	53.34	77.85	13.72	12.45	34.30	221.20	11.7	106.60	1112050	62.25	✓	✓	-	-	-	-
--------	------	-------	-------	-------	-------	-------	-------	-------	--------	------	--------	---------	-------	---	---	---	---	---	---

F_B = AXIAL BREAKING FORCE



No.4



No.11/58



No.12



No.26



No.30



No.107

Available for all chains

Renold Sidebow Chain

Application: Renold sidebow chain is used on curved track conveyors in the bottling, packaging, canning and textile industries. Some typical applications for this chain are:

- To operate a live-roll conveyor on a power curve.
- To carry materials around a curve by use of attachments or slats.
- To transmit power where abnormal chain twist may be encountered.

Product Description

Renold sidebow chain is based on the ANSI and British Standard chain of its respected pitch size. The design of the chain requires a special pin diameter resulting in greater clearance between the pin and bush, allowing the chain to bow.

Attachments can be supplied for this chain, but are made to order. Selection of the chain is not covered in our selection procedures and we advise you to consult our technical staff with the details of your application.

Chain should be protected against dirt/moisture and be lubricated with good quality non-detergent petroleum based oil. Renold Sidebow Chain is pre-lubricated before despatch, but like all chain it needs regular re-lubrication during its working life.

For the majority of applications between -5°C and 60°C, a range of multigrade SAE 20/50 oil would be suitable. Special lubrication or coatings can be provided to match your applicational needs.

Technical Data

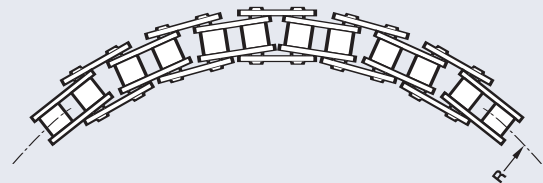
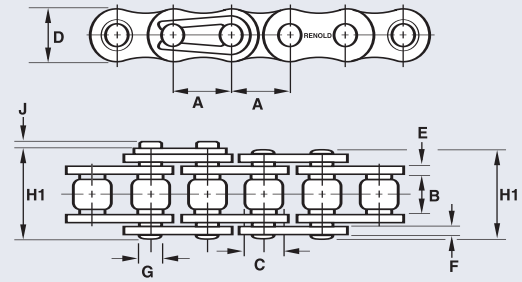

Chain		Technical Details													Connecting Links		
ISO No	Renold Chain No	Pitch inch	Pitch mm	Inside Width Min	Roller Dia Max	Plate Height Max	Plate Width Inner Max	Plate Width Outer Max	Pin Dia Max	Pin Len Max	Con Link Extra Max	Bow Radius	FB Newton Min**	Weight kg/m	No 4	No 11	No 26
		A	A	B	C	D	E	F	G	H	J	R					
-	184110	0.375	9.52	5.72	6.35	8.26	1.3	1.3	3.28	13.5	3.3	195	9000	0.39	✓	✓	✓
-	184111#	0.50	12.7	7.85	7.95	11.89	1.55	1.55	3.42	17.0	3.9	350	13000	0.58	✓	✓	✓
-	184112	0.50	12.7	7.75	8.51	11.89	1.55	1.55	4.45	17.0	3.9	400	19000	0.69	✓	✓	✓
-	184113	0.625	15.875	9.65	10.16	13.72	1.55	1.55	4.70	18.7	4.1	450	22400	0.85	✓	✓	✓
-	184114	0.75	19.05	11.68	12.07	15.93	1.8	1.8	5.72	22.7	4.6	650	29000	1.18	✓	✓	✓
-	184115	1.0	25.4	17.02	15.88	20.57	4.12	3.1	8.27	36.1	5.4	750	65000	2.50	✓	✓	✓
-	184116†	1.25	31.75	9.53	10.16	15.00	2.0	2.0	4.45	21.8	4.1	650	222000	0.69	✓	✓	✓

** To convert to 'lbf', multiply by 0.2248. #Based on ANSI 40 chain. †Based on ANSI 2050 extended pitch chain. Sidebow chain, unlike standard chain, is manufactured with larger clearances between the pin and bush diameters. Therefore, the tolerance over a length of chain is +0.3% and not +0.15% as for standard chain.



No.4



No.11



No.26

RENOLD Synergy® - ANSI Transmission Chain

ISO606 / ANSI B29.100

1

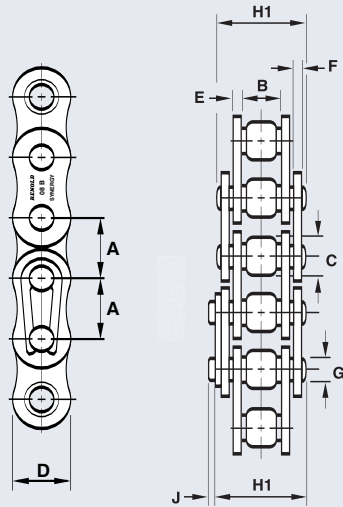

Renold Synergy® ANSI Simplex Transmission Chain

Chain

Technical Details (mm)

Connecting Links

Renold Chain No	ISO No	ANSI No	Pitch	Pitch	Inside	Roller	Plate	Plate	Plate	Pin	Pin	Con	ISO606	Weight	Connecting Links							
			Inch	mm	Width Min	Dia Max	Height Max	Width Inner Max	Width Outer Max	Dia Max	Len Max	Link Extra	Tensile Strength Max	kg/m	No 4	No 107	No 11	No 26	No 58	No 12	No 30	
			A	A	B	C	D	E	F	G	H1	J	(N) ‡									
129037*	06A-1	35	0.375	9.525	4.68	5.08*	9.05	1.25	1.25	3.58	12	1.1	7900	0.35	✓	✓	-	✓	-	✓	✓	
119047	08A-1	40	0.5	12.7	7.85	7.92	12.07	1.55	1.55	3.98	16.4	1.4	13900	0.6	✓	✓	✓	✓	-	✓	✓	
119057	10A-1	50	0.625	15.875	9.4	10.16	15.09	2.03	2.03	5.09	20.4	1.1	21800	1	✓	✓	✓	✓	-	✓	✓	
119067	12A-1	60	0.75	19.05	12.57	11.91	18.1	2.39	2.39	5.96	25.3	1.1	31300	1.47	✓	✓	✓	✓	-	✓	✓	
119087	16A-1	80	1.0	25.4	15.75	15.88	24.13	3.25	3.25	7.94	32.7	3	55600	2.8	✓	✓	✓	-	✓	✓	-	
119107	20A-1	100	1.25	31.75	18.9	19.05	30.17	4.06	4.06	9.54	39.7	4.2	87000	4.2	✓	✓	✓	-	✓	✓	-	
119127	24A-1	120	1.5	38.1	25.23	22.23	36.2	4.8	4.8	11.11	49.3	5.3	125000	5.7	✓	✓	✓	-	✓	✓	-	
119147	28A-1	140	1.75	44.45	25.23	25.4	42.23	5.61	5.61	12.71	52.9	5.2	170000	7.8	✓	✓	✓	-	✓	✓	-	
119167	32A-1	160	2	50.8	31.55	28.58	48.26	6.35	6.35	14.29	63.1	6.5	223000	10.4	✓	✓	✓	-	✓	✓	-	

* BUSH CHAIN

‡ RENOLD SYNERGY FAR EXCEEDS THE ISO606 MINIMUM TENSILE STRENGTH REQUIREMENT, BUT RENOLD DO NOT CONSIDER THAT THIS FIGURE PROVIDES A USEFUL INDICATOR TO THE KEY CHAIN PERFORMANCE AREAS OF WEAR AND FATIGUE.



link no. 4



link no. 107



link no. 11/58



link no. 26



link no. 12



link no. 30

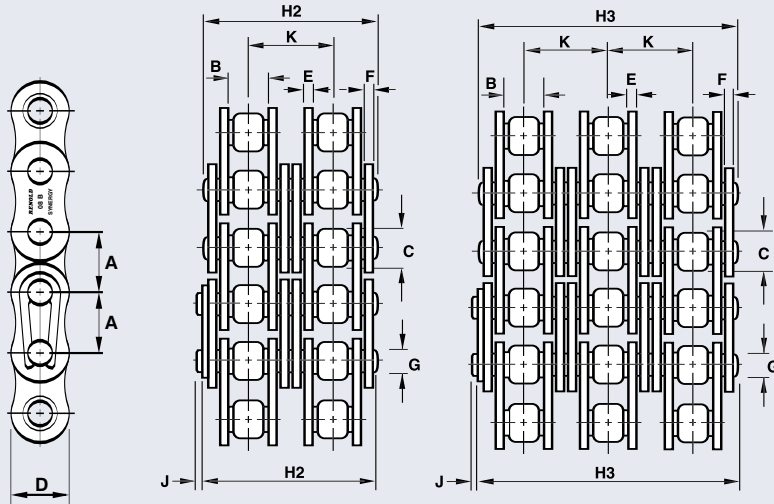

link no. 4



link no. 26



link no. 107



link no. 12



link no. 11/58

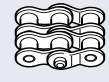

link no. 30

1

Renold Synergy® ANSI Duplex Transmission Chain

Chain

Technical Details (mm)

Connecting Links

Renold Chain No	ISO No	ANSI No	Pitch	Pitch	Inside	Roller	Plate	Plate	Plate	Pin	Pin	Con	Trans	ISO606	Weight	No	No	No	No	No	No	No
			Inch	mm	Width Min	Dia Max	Height Max	Width Outer Max	Width Max	Width Max	Dia Max	Len Max	Link Extra	Pitch Nom	Tensile Strength Max	kg/m	4	107	11	26	58	12
			A	A	B	C	D	E	F	G	H2	J	K	(N) ‡								
125037*	06A-2	35-2	0.375	9.525	4.68	5.08*	9.05	1.25	1.25	3.58	22.2	1.1	10.13	15800	0.7	✓	✓	-	✓	-	✓	✓
115047	08A-2	40-2	0.5	12.7	7.85	7.92	12.07	1.55	1.55	3.98	30.8	1.4	14.38	27800	1.2	✓	✓	✓	✓	-	✓	✓
115057	10A-2	50-2	0.625	15.875	9.4	10.16	15.09	2.03	2.03	5.09	38.4	1.1	18.11	43600	2.1	✓	✓	✓	✓	-	✓	✓
115067	12A-2	60-2	0.75	19.05	12.57	11.91	18.1	2.39	2.39	5.96	48.1	1.1	22.78	62600	3.05	✓	✓	✓	✓	-	✓	✓
115087	16A-2	80-2	1.0	25.4	15.75	15.88	24.13	3.25	3.25	7.94	61.9	3	29.29	111200	5.5	✓	✓	✓	-	✓	✓	-
115107	20A-2	100-2	1.25	31.75	18.9	19.05	30.17	4.06	4.06	9.54	75.4	4.2	35.76	174000	8.4	✓	✓	✓	-	✓	✓	-
115127	24A-2	120-2	1.5	38.1	25.23	22.23	36.2	4.8	4.8	11.11	94.7	5.3	45.44	250000	11	✓	✓	✓	-	✓	✓	-
115147	28A-2	140-2	1.75	44.45	25.23	25.4	42.23	5.61	5.61	12.71	101.8	5.2	48.87	340000	15.5	✓	✓	✓	-	✓	✓	-
115167	32A-2	160-2	2	50.8	31.55	28.58	48.26	6.35	6.35	14.29	121.6	6.5	58.55	446000	20.6	✓	✓	✓	-	✓	✓	-

Renold Synergy® ANSI Triplex Transmission Chain

Chain

Technical Details (mm)

Connecting Links

Renold Chain No	ISO No	ANSI No	Pitch	Pitch	Inside	Roller	Plate	Plate	Plate	Pin	Pin	Con	Trans	ISO606	Weight	No	No	No	No	No	No	No
			Inch	mm	Width Min	Dia Max	Height Max	Width Inner Max	Width Max	Width Max	Dia Max	Len Max	Link Extra	Pitch Nom	Tensile Strength Max	kg/m	4	107	11	26	58	12
			A	A	B	C	D	E	F	G	H3	J	K	(N) ‡								
127037*	06A-3	35-3	0.375	9.525	4.68	5.08*	9.05	1.25	1.25	3.58	32.2	1.1	10.13	23700	1.05	✓	✓	-	✓	-	✓	✓
117047	08A-3	40-3	0.5	12.7	7.85	7.92	12.07	1.55	1.55	3.98	45.1	1.4	14.38	41700	1.85	✓	✓	✓	✓	-	✓	✓
117057	10A-3	50-3	0.625	15.875	9.4	10.16	15.09	2.03	2.03	5.09	56.5	1.1	18.11	65400	3.15	✓	✓	✓	✓	-	✓	✓
117067	12A-3	60-3	0.75	19.05	12.57	11.91	18.1	2.39	2.39	5.96	70.9	1.1	22.78	93900	4.55	✓	✓	✓	✓	-	✓	✓
117087	16A-3	80-3	1.0	25.4	15.75	15.88	24.13	3.25	3.25	7.94	91.2	3	29.29	166800	8.3	✓	✓	✓	-	-	✓	-
117107	20A-3	100-3	1.25	31.75	18.9	19.05	30.17	4.06	4.06	9.54	111.2	4.2	35.76	261000	12.6	✓	✓	✓	-	-	✓	-
117127	24A-3	120-3	1.5	38.1	25.23	22.23	36.2	4.8	4.8	11.11	140.2	5.3	45.44	375000	16.7	✓	✓	✓	-	-	✓	-
117147	28A-3	140-3	1.75	44.45	25.23	25.4	42.23	5.61	5.61	12.71	150.7	5.2	48.87	510000	23.1	✓	✓	✓	-	-	✓	-
117167	32A-3	160-3	2	50.8	31.55	28.58	48.26	6.35	6.35	14.29	180.2	6.5	58.55	669000	31	✓	✓	✓	-	-	✓	-

* BUSH CHAIN

‡ RENOLD SYNERGY FAR EXCEEDS THE ISO606 MINIMUM TENSILE STRENGTH REQUIREMENT, BUT RENOLD DO NOT CONSIDER THAT THIS FIGURE PROVIDES A USEFUL INDICATOR TO THE KEY CHAIN PERFORMANCE AREAS OF WEAR AND FATIGUE.

A&S ANSI Transmission Chain

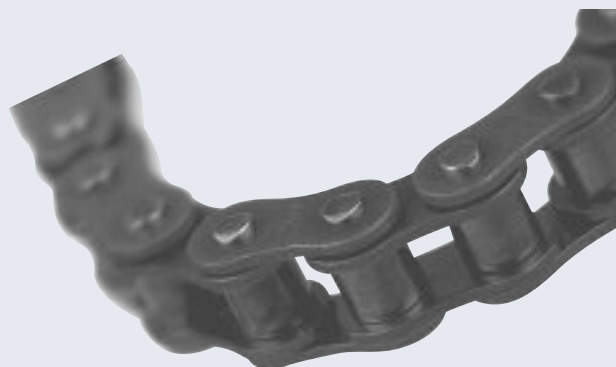
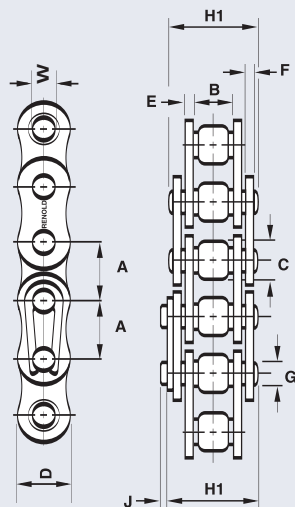

A&S ANSI Standard Simplex Transmission Chain

Chain

Technical Details (mm)

Connecting Links

Renold Chain No	ISO No	Pitch Inch	Pitch mm	Inside Width Min	Roller Dia Max	Plate Height Max	Plate Width Inner Max	Plate Width Outer Max	Pin Dia Max	Pin Len Max	Con Link Extra Max	Trans Pitch Norm	ISO606 Tensile Strength Min (N) ‡	Weight kg/m	No	No	No	No
															4	7	26	30
		A	A	B	C	D	E	F	G	H1	J	K						
100 00 83	03C-1	0.25	6.35	3.10	3.30	6.00	0.73	0.73	2.31	9.10	2.50	-	3500	0.13	✓	✓	✓	✓
100 00 86	06C-1	0.375	9.525	4.68	5.08	9.00	1.25	1.25	3.58	13.20	3.30	-	7900	0.35	✓	✓	✓	✓
100 00 90	08A-1	0.500	12.70	7.85	7.95	12.00	1.50	1.50	3.96	17.80	3.90	-	13900	0.60	✓	✓	✓	✓
100 00 95**	10A-1	0.625	15.875	9.40	10.16	15.00	2.00	2.00	5.08	21.80	4.10	-	21800	1.00	✓	✓	✓	✓
100 02 49	-	0.625	15.875	9.40	10.16	14.50	2.40	2.40	5.08	22.00	4.10	-	36800	1.20	✓	✓	✓	-
100 01 02**	12A-1	0.750	19.05	12.57	11.91	18.00	2.40	2.40	5.94	26.90	4.60	-	31300	1.50	✓	✓	✓	✓
100 01 00	-	0.750	19.05	12.57	11.91	17.40	3.17	3.17	5.94	28.60	4.60	-	31300	1.80	✓	✓	✓	✓
100 08 86	-	0.750	19.05	12.57	11.91	17.40	3.17	3.17	5.94	28.60	4.60	-	55000	1.80	✓	✓	✓	✓
100 01 10	16B-1	1.000	25.40	15.75	15.88	24.10	3.00	3.00	7.92	33.50	5.40	-	55600	2.60	✓	✓	✓	✓
100 01 09	-	1.000	25.40	15.75	15.88	23.00	4.00	4.00	7.92	35.80	5.40	-	55600	2.95	✓	✓	✓	✓
100 08 87	-	1.000	25.40	15.75	15.88	23.00	4.00	4.00	7.92	35.80	5.40	-	80000	2.95	✓	✓	✓	✓
100 01 16	20A-1	1.250	31.75	18.90	19.05	30.10	4.00	4.00	9.53	41.10	6.10	-	87000	3.70	✓	✓	-	✓
100 07 91	-	1.250	31.75	18.90	19.05	28.90	4.80	4.80	9.53	42.60	6.10	-	87000	4.40	✓	✓	-	✓
100 01 20	24A-1	1.500	38.10	25.22	22.23	36.20	4.80	4.80	11.10	50.80	6.10	-	125000	5.50	✓	✓	-	✓
100 01 24	28A-1	1.750	44.45	25.22	25.40	42.20	5.60	5.60	12.70	54.90	7.40	-	170000	7.50	✓	✓	-	✓
100 01 26	32A-1	2.000	50.80	31.55	28.58	48.20	6.30	6.30	14.27	65.50	7.90	-	223000	9.70	✓	✓	-	✓
100 09 14	40A-1	2.500	63.50	37.85	39.68	60.30	8.10	8.10	19.84	80.30	10.00	-	347000	15.80	✓	✓	-	✓



link no. 4



link no. 107



link no. 26



link no. 30

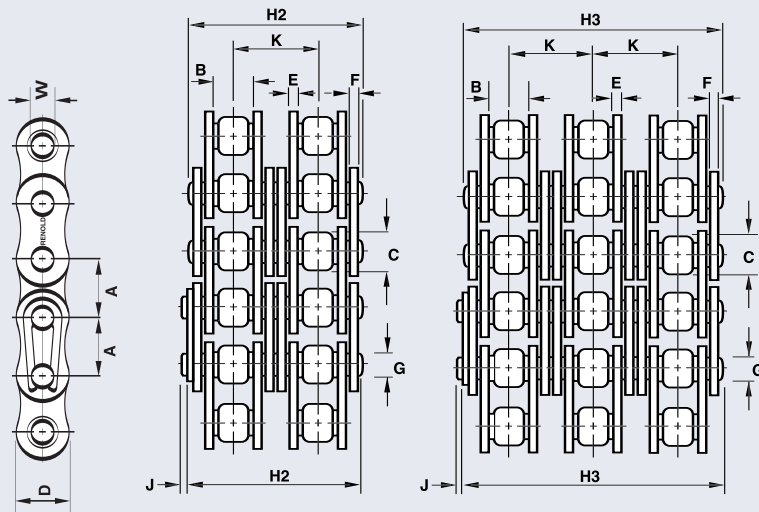

link no. 4



link no. 26



link no. 30



link no. 107

A&S ANSI Standard Duplex Transmission Chain

Chain

Technical Details (mm)

Connecting Links

Renold Chain No	ISO No	Pitch Inch	Pitch mm	Inside Width Min	Roller Dia Max	Plate Height Max	Plate Width Inner Max	Plate Width Outer Max	Pin Dia Max	Pin Len Max	Con Link Extra Max	Trans Pitch Norm	ISO606 Tensile Strength Min	Weight kg/m	No	No	No	No
															4	7	26	30
		A	A	B	C	D	E	F	G	H2	J	K	(N) ‡					
100 00 84	04C-2	0.25	6.35	3.10	3.30	6.00	0.73	0.73	2.31	15.50	2.50	6.40	7000	0.26	✓	✓	✓	✓
100 00 87	06C-2	0.375	9.525	4.68	5.08	9.00	1.25	1.25	3.58	23.40	3.30	10.13	15800	0.70	✓	✓	✓	✓
100 00 91	08A-2	0.500	12.70	7.85	7.95	12.00	1.50	1.50	3.96	32.30	3.90	14.38	27800	1.20	✓	✓	✓	✓
100 00 96	10A-2	0.625	15.875	9.40	10.16	15.00	2.00	2.00	5.08	39.90	4.10	18.11	43600	1.90	✓	✓	✓	✓
100 01 03	12A-2	0.750	19.05	12.57	11.91	18.00	2.40	2.40	5.94	49.80	4.60	22.78	62600	2.90	✓	✓	✓	✓
100 01 01	-	0.75	19.05	12.57	11.91	17.40	3.17	3.17	5.94	54.70	4.60	26.11	62600	3.50	✓	✓	✓	✓
100 01 11	16A-2	1.000	25.40	15.75	15.88	24.10	3.00	3.00	7.92	62.70	5.40	29.29	111200	5.00	✓	✓	✓	✓
100 00 86	-	1.000	25.40	15.75	15.88	23.00	4.00	4.00	7.92	68.10	5.40	32.59	112200	5.75	✓	-	✓	-
100 01 17	20A-2	1.250	31.75	18.90	19.05	30.10	4.00	4.00	9.53	77.00	6.10	35.76	174000	7.30	✓	✓	-	✓
100 01 21	24A-2	1.500	38.10	25.22	22.23	36.20	4.80	4.80	11.10	96.30	6.60	45.44	250000	10.90	✓	✓	-	✓
100 01 25	28A-2	1.750	44.45	25.22	25.40	42.20	5.60	5.60	12.70	103.00	7.40	48.87	340000	14.40	✓	✓	-	✓
100 01 27	32A-2	2.000	50.80	31.55	28.58	48.20	6.30	6.30	14.27	124.00	7.90	58.55	446000	19.00	✓	✓	-	✓

A&S ANSI Standard Triplex Transmission Chain

Chain

Technical Details (mm)

Connecting Links

Renold Chain No	ISO No	Pitch Inch	Pitch mm	Inside Width Min	Roller Dia Max	Plate Height Max	Plate Width Inner Max	Plate Width Outer Max	Pin Dia Max	Pin Len Max	Con Link Extra Max	Trans Pitch Norm	ISO606 Tensile Strength Min	Weight kg/m	No	No	No	No
															4	7	26	30
		A	A	B	C	D	E	F	G	H3	J	K	(N) ‡					
100 00 85	04C-3	0.25	6.35	3.10	3.30	6.00	0.73	0.73	2.31	21.80	2.50	6.40	10500	0.39	✓	✓	✓	-
100 00 88	06C-3	0.375	9.525	4.68	5.08	9.00	1.25	1.25	3.58	33.50	3.30	10.13	23700	1.05	✓	✓	✓	✓
100 00 92	08A-3	0.500	12.70	7.85	7.95	12.00	1.50	1.50	3.96	46.70	3.90	14.38	41700	1.80	✓	✓	✓	✓
100 00 97	10A-3	0.625	15.875	9.40	10.16	15.00	2.00	2.00	5.08	57.90	4.10	18.11	65400	2.90	✓	✓	✓	✓
100 01 04	12A-3	0.750	19.05	12.57	11.91	18.00	2.40	2.40	5.94	72.60	4.60	22.78	93900	4.30	✓	✓	✓	✓
100 02 87	-	0.75	19.05	12.57	11.91	17.40	3.17	3.17	5.94	80.80	4.60	26.11	93900	5.20	✓	✓	-	✓
100 01 12	16A-3	1.000	25.40	15.75	15.88	24.10	3.00	3.00	7.92	113.00	5.40	29.29	166800	7.50	✓	✓	✓	✓
100 01 18	20A-3	1.250	31.75	18.90	19.05	30.10	4.00	4.00	9.53	113.00	6.10	35.76	261000	11.00	✓	✓	✓	✓
100 01 22	24A-3	1.500	38.10	25.22	22.23	36.20	4.08	4.80	11.10	141.00	6.60	45.44	375000	16.50	✓	✓	✓	✓
100 01 91	28A-3	1.750	44.45	25.22	25.40	42.20	5.60	5.60	12.70	152.00	7.40	48.87	510000	21.70	✓	✓	✓	✓
100 01 92	32A-3	2.000	50.80	31.55	28.58	48.20	6.30	6.30	14.27	182.00	7.90	58.55	669000	128.30	✓	✓	✓	✓

ANSI Small and Large Pitch Chain

ISO 606 / ANSI B29.100

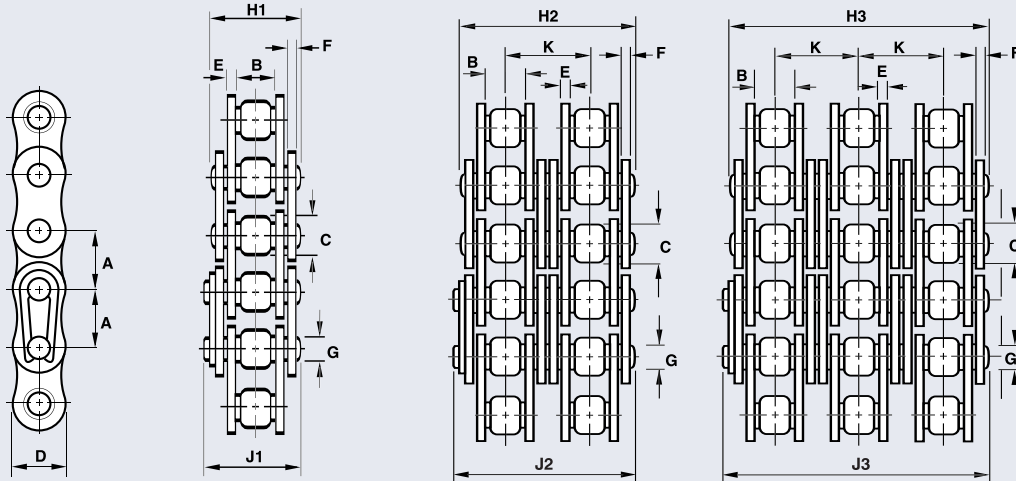

ANSI Small and Large Pitch Chain

Chain Technical Details (mm)

Connecting Links

Renold Chain No	ISO No	Pitch Inch	Pitch mm	Inside Width Min	Roller Dia Max	Plate Height Max	Plate Width Inner Max	Plate Width Outer Max	Pin Dia Max	Pin Len Max	Con Link Extra Max	Trans Pitch	ISO606 Tensile Strength	Weight kg/m	Connecting Links						
															No 4	No 107	No 11	No 26	No 12	No 30	No 58

Simplex

129023	25-1	0.25	6.35	3.1	3.3	6.02	0.76	0.76	2.3	8.6	0.8	-	3500	0.13	✓	✓	-	✓	-	✓	-
119143	140-1	1.75	44.45	25.23	25.4	42.23	5.61	5.61	12.71	54.9	7.4	-	170000	7.8	✓	✓	✓	-	✓	-	✓
119163	160-1	2.0	50.8	31.55	28.58	48.26	6.35	6.35	14.29	65.5	7.9	-	223000	10.4	✓	✓	✓	-	✓	-	✓
119183	180-1	2.25	57.15	35.48	35.71	54.3	7.11	7.11	17.46	73.9	9.1	-	281000	13.94	✓	✓	✓	-	-	-	✓
119203	200-1	2.5	63.5	37.85	39.67	60.33	8.13	8.13	19.85	80.3	10.2	-	355000	17.3	✓	✓	✓	-	✓	-	✓
119243	240-1	3.0	76.2	47.35	47.62	72.39	9.8	9.8	23.8	95.5	10.5	-	500000	25.0	✓	✓	✓	-	-	-	✓

Duplex

127037	35-2	0.375	9.525	4.68	5.08	9.0	1.25	1.25	3.58	23.4	3.3	10.13	20000	0.7	-	-	-	-	-	-	-
115143	140-2	1.75	44.45	25.23	25.4	42.23	5.61	5.61	12.71	103.6	7.4	48.87	340000	15.5	✓	✓	✓	-	✓	-	✓
115163	160-2	2.0	50.8	31.55	28.58	48.26	6.35	6.35	14.29	65.5	7.9	58.55	223000	10.4	✓	✓	✓	-	✓	-	✓
115183	180-2	2.25	57.15	35.48	35.71	54.3	7.11	7.11	17.46	140.8	9.1	65.84	562000	27.72	✓	✓	✓	-	-	-	✓
115203	200-2	2.5	63.5	37.85	39.67	60.33	8.13	8.13	19.85	151.9	10.2	71.55	630000	34.4	✓	✓	✓	-	✓	-	✓
115243	240-2	3.0	76.2	47.35	47.62	72.39	9.8	9.8	23.8	183.33	10.5	87.83	1000800	50.0	✓	✓	✓	-	-	-	✓

Triplex

117143	140-3	1.75	44.45	25.23	25.4	42.23	5.61	5.61	12.71	152.4	7.4	48.87	510000	23.1	✓	✓	✓	-	✓	-	-
117163	160-3	2.0	50.8	31.55	28.58	48.26	6.35	6.35	14.29	182.9	7.9	58.55	669000	31.0	✓	✓	✓	-	✓	-	-
117183	180-3	2.25	57.15	35.48	35.71	54.3	7.11	7.11	17.46	206.0	9.1	65.84	843000	41.5	✓	✓	✓	-	-	-	-
117203	200-3	2.5	63.5	37.85	39.67	60.33	8.13	8.13	19.85	220.0	10.2	71.55	950000	51.2	✓	✓	✓	-	✓	-	-
117243	240-3	3.0	76.2	47.35	47.62	72.39	9.8	9.8	23.81	271.3	10.5	87.83	1500000	75.0	✓	✓	✓	-	-	-	✓



No.4



No.107



No.26



No.11



No.12



No.30

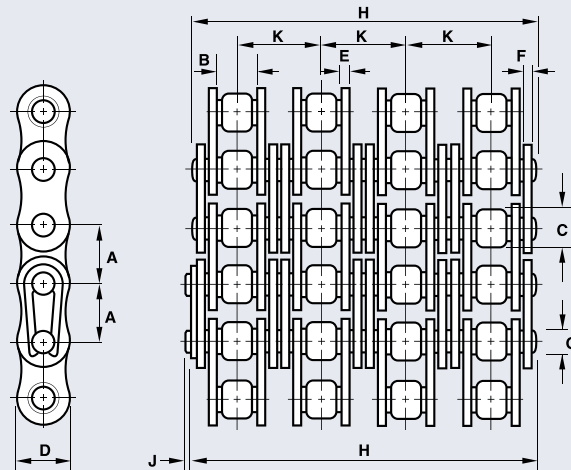

ANSI Standard - Multiplex

Chain

Technical Details

Connecting Links

ISO No	ANSI No	Renold Chain No	Pitch Inch	Pitch mm	Inside Width Min	Roller Dia Max	Plate Height Max	Plate Width Inner Max	Plate Width Outer Max	Pin Dia Max	Pin Len Max	Con Link Extra Max	Trans Pitch	FB Newtons Min	Weight kg/m	Connecting Links														
																No 4	No 107	No 26	No 11/58											
																A	A	B	C	D	E	F	G	H	J	K				
08A-4	40-4	118043	0.50	12.7	7.85	7.92	11.15	1.55	1.55	3.98	59.7	3.9	14.38	67600	2.52	✓	✓	✓	✓											
10A-4	50-4	118053	0.625	15.875	9.4	10.16	14.55	2.03	2.03	5.07	75.2	4.1	18.11	111200	4.2	✓	✓	-	✓											
10A-5	50-5	185183	0.625	15.875	9.4	10.16	14.55	2.03	2.03	5.07	93.3	4.1	18.11	139000	5.25	✓	✓	-	✓											
10A-6	50-6	187203	0.625	15.875	9.4	10.16	14.55	2.03	2.03	5.07	111.3	4.1	18.11	166800	6.3	✓	✓	-	✓											
12A-4	60-4	118063	0.75	19.05	12.57	11.91	17.45	2.39	2.39	5.96	94.3	4.6	22.78	151250	6.2	✓	✓	-	✓											
12A-5	60-5	185733	0.75	19.05	12.57	11.91	17.45	2.39	2.39	5.96	116.9	4.6	22.78	190000	7.75	✓	✓	-	✓											
12A-6	60-6	187453	0.75	19.05	12.57	11.91	17.45	2.39	2.39	5.96	139.7	4.6	22.78	226800	9.3	✓	✓	-	✓											
16A-4	80-4	118083	1.0	25.4	15.38	15.75	24.05	3.25	3.25	7.93	120.7	5.4	29.29	258000	11.2	✓	✓	-	✓											
16A-5	80-5	187813	1.0	25.4	15.38	15.75	24.05	3.25	3.25	7.93	149.9	5.4	29.29	322500	14.0	✓	✓	-	✓											
16A-6	80-6	187823	1.0	25.4	15.38	15.75	24.05	3.25	3.25	7.93	179.4	5.4	29.29	387000	16.8	✓	✓	-	✓											
16A-8	80-8	187953	1.0	25.4	15.38	15.75	24.05	3.25	3.25	7.93	237.8	5.4	29.29	516000	22.4	✓	✓	-	✓											
20A-4	100-4	118103	1.25	31.75	19.05	19.05	29.97	4.06	4.06	9.54	147.1	6.1	35.76	418150	16.8	✓	✓	-	✓											
20A-5	100-5	184823	1.25	31.75	19.05	19.05	29.97	4.06	4.06	9.54	182.9	6.1	35.76	522600	21.0	✓	✓	-	✓											
20A-6	100-6	184833	1.25	31.75	19.05	19.05	29.97	4.06	4.06	9.54	218.7	6.1	35.76	627200	25.2	✓	✓	-	✓											
24A-4	120-4	118123	1.50	38.1	25.68	22.23	35.89	4.8	4.8	11.11	185.7	6.6	45.44	570000	22.92	✓	✓	-	✓											
24A-5	120-5	185983	1.50	38.1	25.68	22.23	35.89	4.8	4.8	11.11	231.2	6.6	45.44	711700	27.96	✓	✓	-	✓											
24A-6	120-6	185973	1.50	38.1	25.68	22.23	35.89	4.8	4.8	11.11	276.6	6.6	45.44	854000	33.5	✓	✓	-	✓											
24A-8	120-8	185993	1.50	38.1	25.68	22.23	35.89	4.8	4.8	11.11	367.6	6.6	45.44	1138000	44.65	✓	✓	-	✓											
28A-4	140-4	118143	1.75	44.45	25.73	25.4	41.81	5.61	5.61	12.64	199.7	7.4	48.87	765000	30.21	✓	✓	-	✓											
28A-5	140-5	188833	1.75	44.45	25.73	25.4	41.81	5.61	5.61	12.64	248.4	7.4	48.87	956400	37.72	✓	✓	-	✓											
28A-6	140-6	184933	1.75	44.45	25.73	25.4	41.81	5.61	5.61	12.64	297.5	7.4	48.87	1147680	45.24	✓	✓	-	✓											
32A-4	160-4	118163	2.00	50.8	32.13	28.58	47.73	6.35	6.35	14.29	238.8	7.9	58.55	978600	38.9	✓	✓	-	✓											
40A-4	200-4	118203	2.50	63.5	38.15	39.67	59.56	8.13	8.13	19.81	291.6	10.2	71.55	1690000	68.24	✓	✓	-	✓											

FB = AXIAL BREAKING FORCE
DETACHABLE COTTERED CHAIN - SEE OILFIELD CHAIN PAGE 120 - 121

Connecting links

Note: No.12 Crank links - please consult Renold.



No.4



No.107



No.11, 58



No.26

RENOLD Standard Attachments

for ANSI Simplex Roller Chain

1

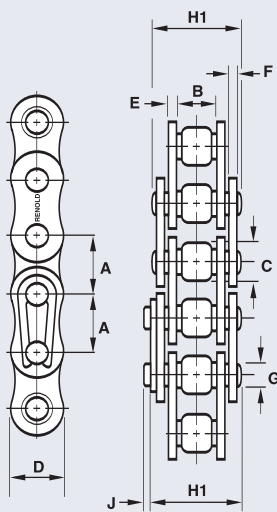
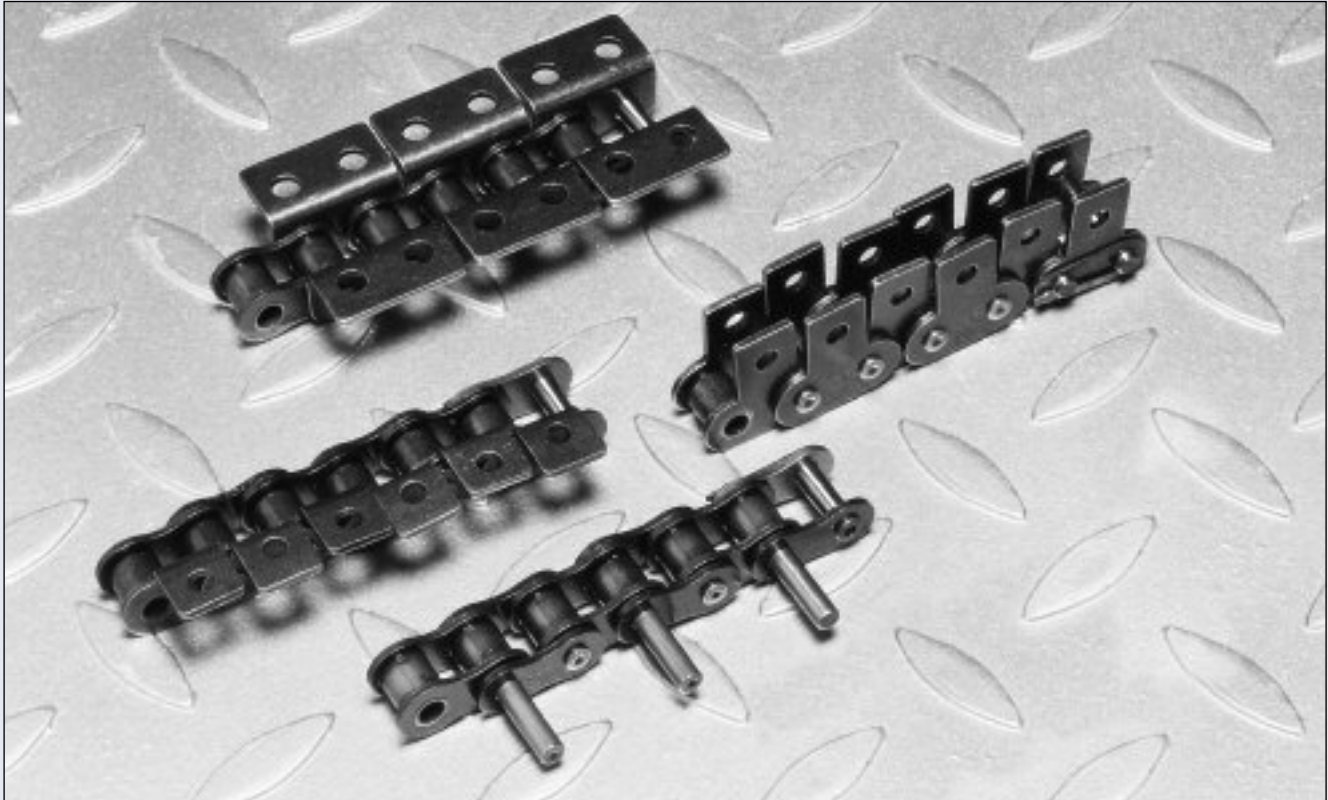

Renold ANSI standard transmission chain can be adapted for conveying duties by the fitment of attachment plates shown on this page. The attachments can be assembled on one or both sides of the chain at any desired pitch spacing.

- Note:
1. K2 attachments cannot be assembled on adjacent inner and outer links on the same side of the chain.
 2. M1 attachments cannot be assembled next to a No. 30 (Cranked link double) joint.

Bearing pins with an extension on one side of the chain can be included at any desired spacing and afford a simple means by which attachments or tubular staybars can be secured to chain.

Spare Parts

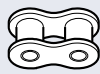

No. 4
Inner link



No. 26
Connecting link-spring clip
(for chains up to .75" pitch)



No. 58
Connecting link-press fit
(for chains of 1" pitch)



No. 107
Riveting
pin link

Base Chain ANSI Standard - Simplex

Chain Technical Details

ANSI No	Renold Chain No	Pitch Inch	Pitch mm	Inside Width Min	Roller Dia Max	Plate Height Max	Plate Width Inner Max	Plate Width Outer Max	Pin Dia Max	Pin Len Max	Con Link Extra Max	F _B Newtons Min	Weight kg/m
		A	A	B	C	D	E	F	G	H1	J		
35	129033*	0.375	9.525	4.68	5.08*	8.66	1.3	1.3	3.59	15.5	3.3	7900	0.33
40	119043	0.50	12.7	7.85	7.92	11.15	1.55	1.55	3.98	17.8	3.9	13900	0.63
50	119053	0.625	15.875	9.4	10.16	14.55	2.03	2.03	5.07	21.8	4.1	21800	1.05
60	119063	0.75	19.05	12.58	11.91	17.45	2.39	2.39	5.96	26.9	4.6	31300	1.55
80	119083	1.0	25.4	15.75	15.88	24.05	3.25	3.25	7.93	33.5	5.4	55600	2.8

* BUSH CHAIN/BUSH DIAMETER.



Renold ANSI Standard K1 Attachments

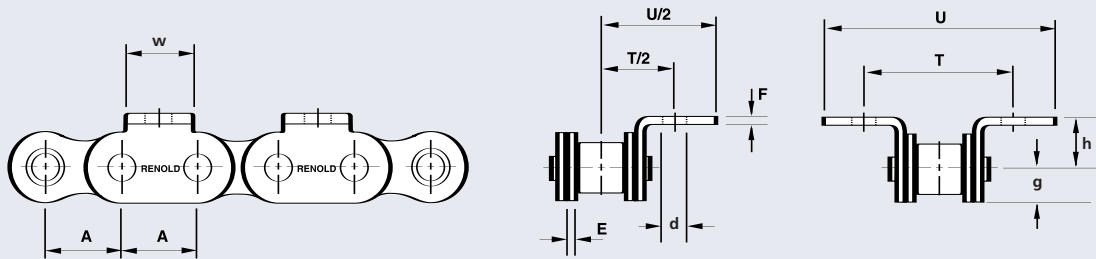

ANSI No	Renold Chain No	Pitch	Pitch	E	F	w	h	d	g	T	U
		Inch	mm								
40	119043	0.5	12.7	1.52	1.52	9.5	7.9	3.2	6.01	25.3	35.3
50	119053	0.625	15.875	2.03	2.03	12.7	10.3	5.2	7.54	31.8	46.02
60	119063	0.75	19.05	2.39	2.39	15.9	12.14	5.2	9.04	38.1	54.23
80	119083	1.0	25.4	3.15	3.15	19.05	15.875	6.73	11.43	50.8	70.08

ISO/ANSI Standard K1 Attachments

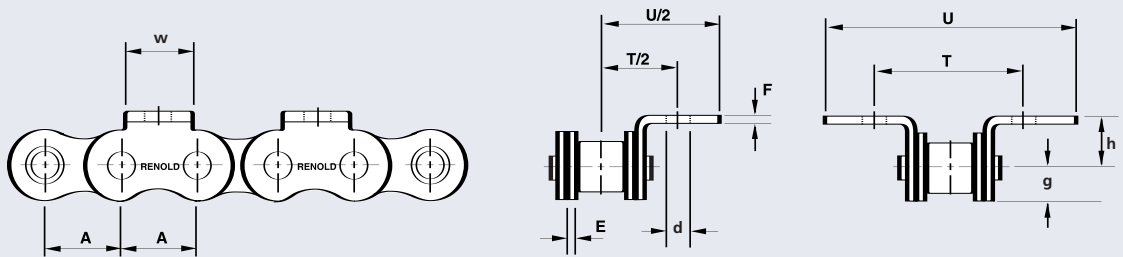

ANSI No	Renold Chain No	Pitch	Pitch	E	F	w	h	d	g	T	U
		Inch	mm								
40	119043	0.5	12.7	1.51	1.51	9.5	7.9	3.3	5.5	25.4	35.8
50	119053	0.625	15.875	2.0	2.0	12.7	10.3	5.3	7.2	31.8	49.8
60	119063	0.75	19.05	2.4	2.4	15.9	11.9	5.3	8.6	38.2	58.0
80	119083	1.0	25.4	3.0	3.0	24.0	15.9	6.6	12.1	50.8	82.6

Standard K2 Attachments

ANSI B29.100 / ISO606

1

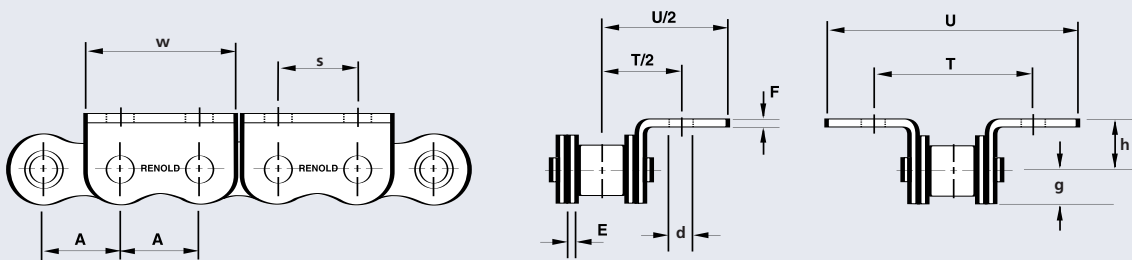
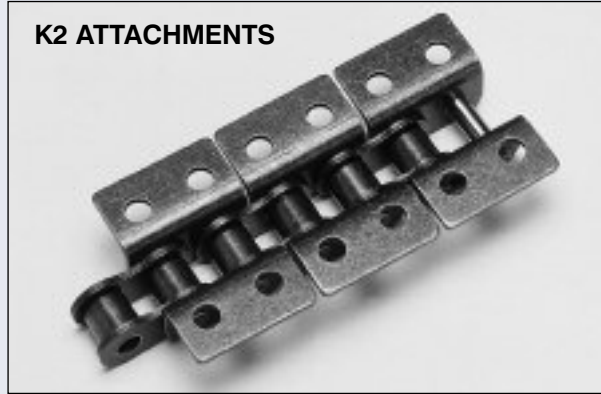

ISO/ANSI Standard K2 Attachments

ANSI No	Renold Chain No	Pitch	Pitch	E	F	h	d	g	w	s	T	U
		Inch	mm									
40	119043	0.5	12.7	1.51	1.51	7.9	3.3	5.5	24.0	12.7	25.4	35.8
50	119053	0.625	15.875	2.0	2.0	10.3	5.3	7.2	29.9	15.8	31.8	49.8
60	119063	0.75	19.05	2.4	2.4	11.9	5.3	8.6	35.6	19.0	38.2	58.0
80	119083	1.0	25.4	3.0	3.0	15.9	6.6	12.1	46.2	25.4	50.8	82.6

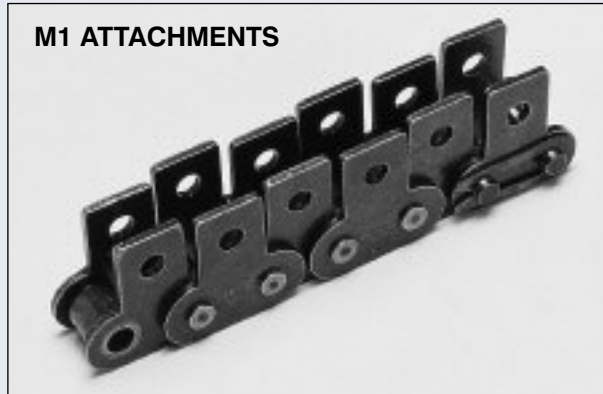

Renold ANSI Standard M1 Attachments

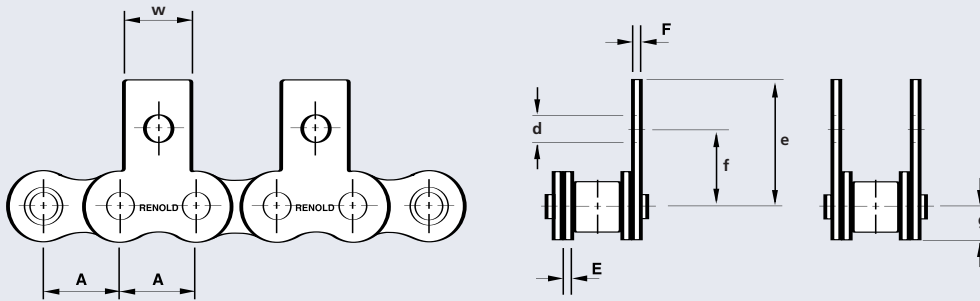

ANSI No	Renold Chain No	Pitch	Pitch	E	F	w	e	f	d	g
		Inch	mm							
40	119043	0.50	12.7	1.52	1.52	9.5	17.4	12.42	3.2	6.01
50	119053	0.625	15.875	2.03	2.03	12.7	22.73	15.7	5.2	7.54
60	119063	0.75	19.05	2.39	2.39	15.9	26.36	18.19	5.2	9.04
80	119083	1.0	25.4	3.15	3.15	19.05	34.29	24.59	6.73	11.43

ISO/ANSI Standard M1 Attachments

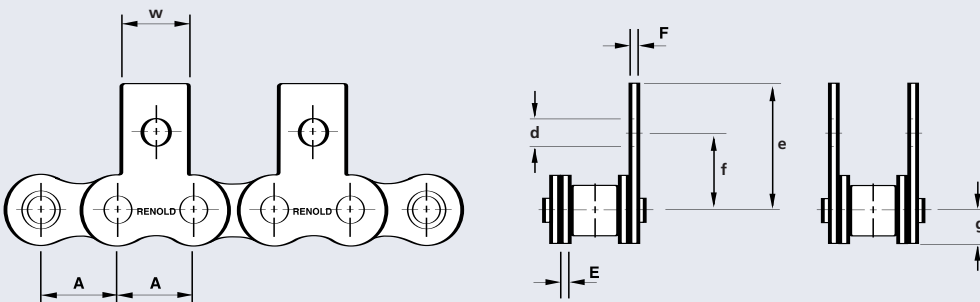

ANSI No	Renold Chain No	Pitch	Pitch	E	F	w	e	f	d	g
		Inch	mm							
40	119043	0.5	12.70	1.51	1.51	9.5	17.5	12.7	3.3	5.5
50	119053	0.625	15.875	2.0	2.0	12.7	24.6	15.9	5.3	7.2
60	119063	0.75	19.05	2.4	2.4	15.9	27.4	18.3	5.3	8.6
80	119083	1.0	25.4	3.0	3.0	24.0	39.7	24.6	6.6	12.1

Standard M2 Attachments

ANSI B29.100 / ISO 606

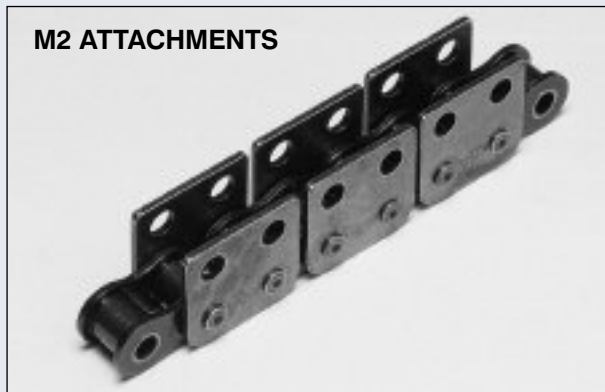

1

ISO/ANSI Standard M2 Attachments

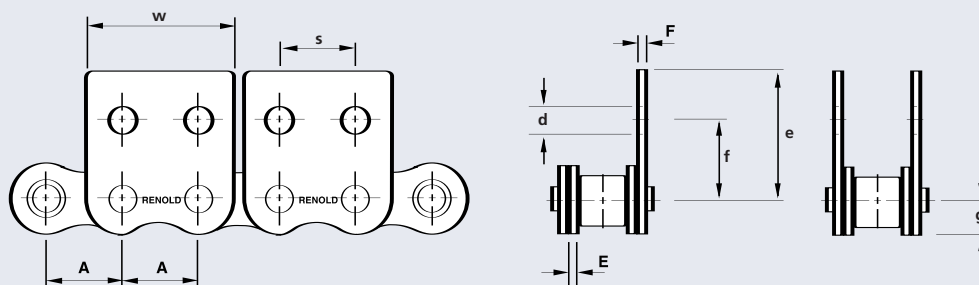

ANSI No	Renold Chain No	Pitch	Pitch	E	F	e	f	d	g	w	s
		Inch	mm								
40	119043	0.5	12.7	1.51	1.51	17.5	12.7	3.3	5.5	24.0	12.7
50	119053	0.625	15.875	2.0	2.0	24.6	15.9	5.3	7.2	29.9	15.8
60	119063	0.75	19.05	2.4	2.4	27.4	18.3	5.3	8.6	35.6	19.0
80	119083	1.0	25.4	3.0	3.0	39.7	24.6	6.6	12.1	46.2	25.4

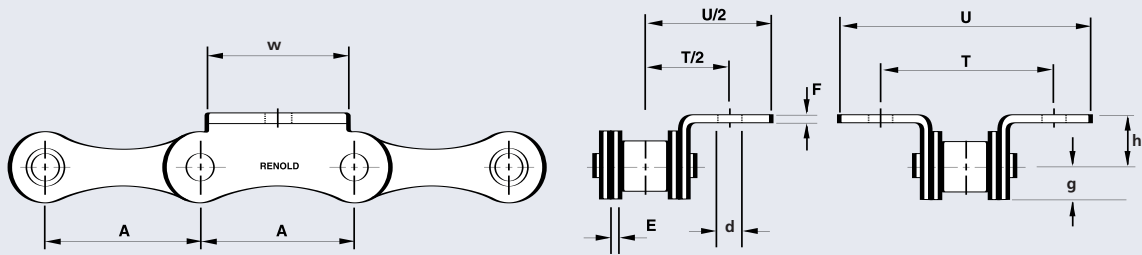

1

Renold ANSI Double Pitch Standard K1 Attachments

ANSI No	Renold Chain No	Pitch	Pitch	E	F	w	h	d	g	T	U
		Inch	mm								
		A	A								
2040	113040	1.0	25.4	1.51	1.51	23.8	9.1	3.3	5.7	25.4	40.6
2050	113050	1.25	31.75	2.0	2.0	25.4	11.1	5.3	7.4	31.8	48.9
2060	113060	1.5	38.1	2.4	2.4	28.6	14.7	5.3	8.8	42.8	58.0
C2060	113560 *	1.5	38.1	3.17	3.17	28.6	14.7	5.3	8.8	42.8	61.6

* STRAIGHT PLATE

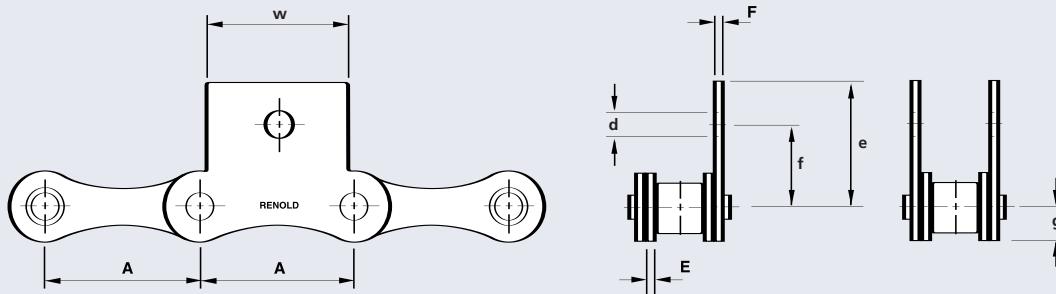

Renold ANSI Double Pitch Standard M1 Attachments

ANSI No	Renold Chain No	Pitch	Pitch	E	F	w	e	f	d	g
		Inch	mm							
		A	A							
2040	113040	1.0	25.4	1.51	1.51	23.8	20.9	11.1	3.3	5.7
2050	113050	1.75	31.75	2.0	2.0	25.4	24.9	14.3	5.3	7.4
2060	113060	1.5	38.1	2.4	2.4	28.6	30.2	19.0	5.3	8.8
C2060	113560 *	1.5	38.1	3.17	3.17	28.6	30.2	19.0	5.3	8.8

* STRAIGHT PLATE

RENOLD ANSI Standard Extended Bearing Pins

ISO606 / ANSI B29.100

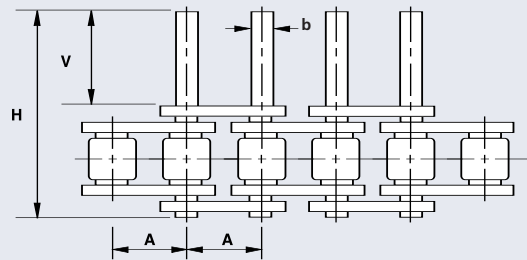

ANSI Standard - Extended Pins

ANSI No	Renold Chain No	Pitch	Pitch	Pin dia. ± .010 b	Extension length ± .25 V	Chain track from chain centre line (max) H
		Inch A	mm A			
35	129033*	0.375	9.525	3.58	9.53	15.5
40	119043	0.5	12.7	3.96	9.73	18.0
50	119053	0.625	15.875	5.08	11.89	22.4
60	119063	0.75	19.05	5.94	14.27	27.2
80	119083†	1.0	25.4	7.92	19.05	35.7

* BUSH CHAIN † EXTENSION GROOVED FOR CIRCLIP :NO.163, 164, 167, AND 168 JOINTS APPLY.

Unit Assemblies



No.463
Outer link



No.464
Outer link



No.465
Connecting
link-spring clip



No.466
Connecting
link-spring clip



No.467



No.468

Attachment Connecting Links For ANSI Simplex Roller Chain

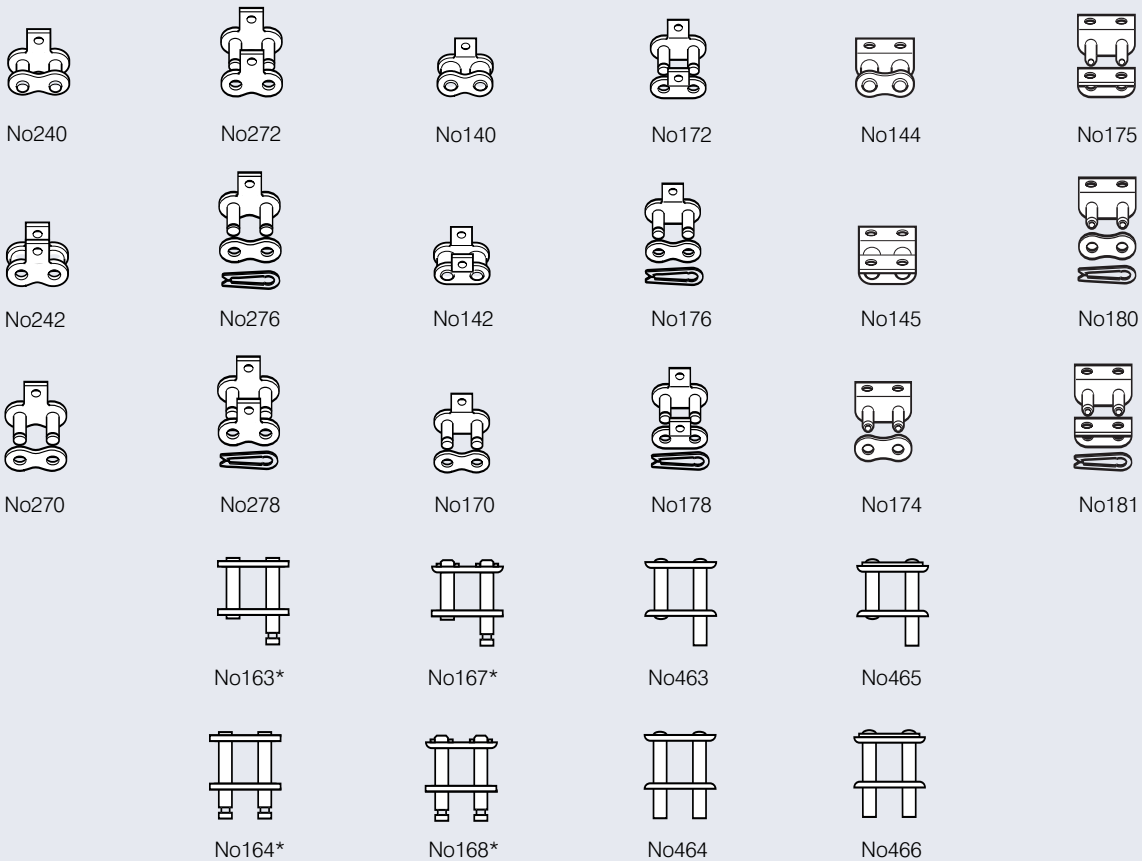

* Ansi 80

Special or Adapted Transmission Chain

In addition to our ranges of standard series chain we can also offer:

- Transmission Chain up to 300mm pitch and 450 tonnes breaking load.
- Standard Series Chain adapted to your unique needs with special attachments.
- Special Chain designed with integral attachments to meet individual requirements.

Renold adapted chain can be in the form of special plates, pin rollers, or blocks which can be designed, manufactured and assembled into chain of all pitch sizes. Attachments can be made from normal materials, stainless steel or plastics. We will be pleased to receive details of your requirements and evaluate them for strength, durability, price and despatch. They can be manufactured from your own designs or adapted from existing drawings. The illustrations show only a small selection of the wide range of variants and these chains have been used successfully in many branches of industry for the feeding, conveying and discharge of a variety of products.

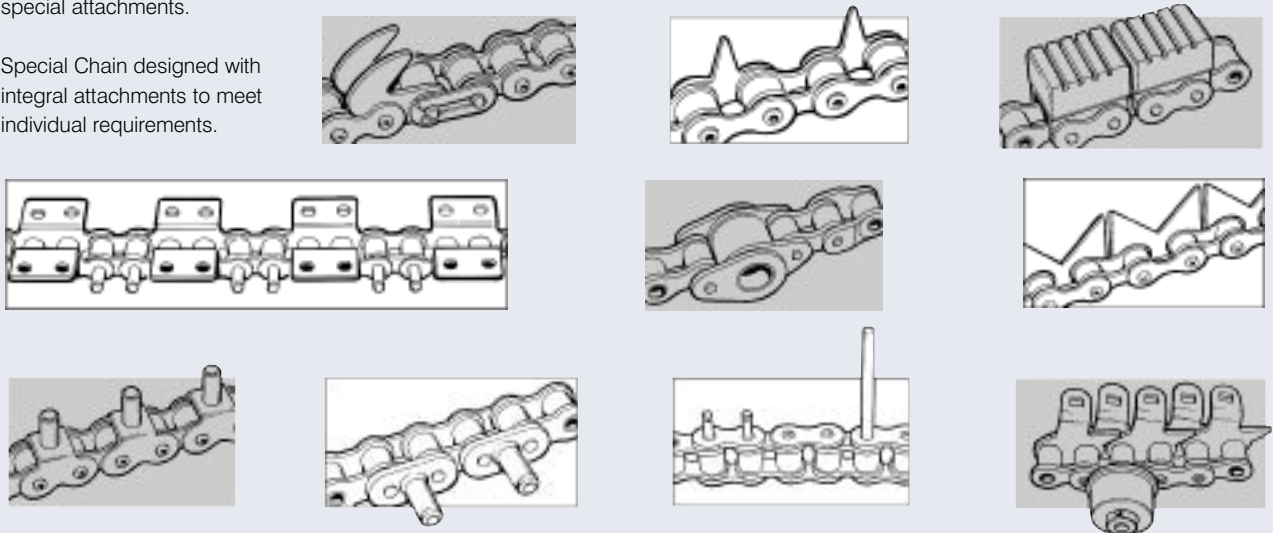

RENOLD Syno Nickel Plated Chain

No need to relubricate this chain!

This dry-to-the-touch chain now includes more performance enhancing characteristics than ever before. Using the latest techniques, Renold have incorporated special surface treatment processes to improve the bonding of the nickel plating. This type of plating is not prone to chipping or peeling as some other plated chains are prone to doing.

The pin coating minimises friction, improving wear life and reducing vibration, while the FDA-approved coating on the roller and the USDA H1-approved lubricant within the chain make it ideal for food processing environments.



At a glance

- Dry-to-the-touch chain
- Never needs relubrication
- FDA-approved coating on rollers
- Nickel-plating on plates won't chip or peel
- Good resistance to corrosion
- USDA H1-approved lubricant inside chain when supplied
- Standard chain dimensions so can be exchanged "like for like"
- Will run on standard sprockets
- BS: 1/2" to 1 1/2" simplex and duplex (06B-1 to 24B-1 and 06B-2 to 24B-2)
- ANSI: 1/2" to 1 1/4" simplex and duplex (40-1 to 100-1 and 40-2 to 100-2)

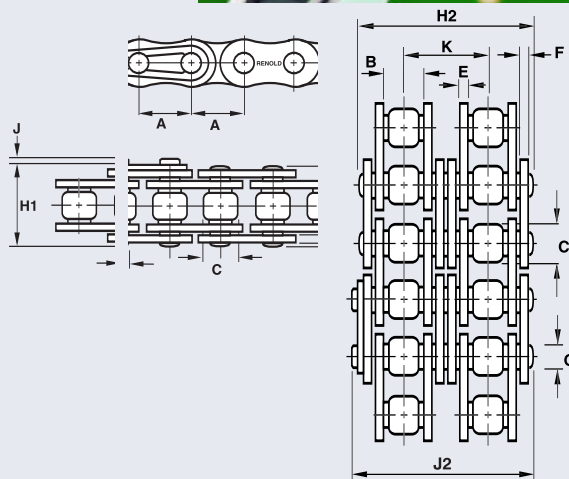

ANSI Standard Syno Nickel Plated Chain - Simplex

Chain		Technical Details (mm)														Connecting Links			
Renold Chain No	ANSI No	Pitch Inch	Pitch mm	Inside Width Min	Roller Dia Max	Plate Height Max	Plate Width Inner Max	Plate Width Outer Max	Pin Dia Max	Pin Len Max	Con Link Extra Max	Transverse Pitch Max	ISO Breaking Load F_B in N Min	Weight kg/m	No 4	No 107	No 26	No 11	
		A	A	B	C	D	E		F	H1	J	K							
119443	40	0.50	12.70	7.85	7.92	11.7	1.80	1.50	3.97	16.9	1.9	-	13900	0.67	✓	✓	✓	✓	
119453	50	0.625	15.875	9.40	10.16	14.6	2.42	2.00	5.08	21.1	2.5	-	21800	1.12	✓	✓	✓	✓	
119463	60	0.75	19.05	12.57	11.91	17.5	3.23	2.40	5.95	27.0	2.5	-	31300	1.73	✓	✓	✓	✓	
119483	80	1.00	25.40	15.75	15.88	23.0	4.06	3.00	7.92	33.7	3.0	-	55600	2.90	✓	✓	✓	✓	
119503	100	1.25	31.75	18.90	19.05	25.3	4.40	4.00	9.53	40.6	3.5	-	87000	3.60	✓	✓	-	✓	

ANSI Standard Syno Nickel Plated Chain - Duplex

Chain		Technical Details (mm)														Connecting Links			
Renold Chain No	ANSI No	Pitch Inch	Pitch mm	Inside Width Min	Roller Dia Max	Plate Height Max	Plate Width Inner Max	Plate Width Outer Max	Pin Dia Max	Pin Len Max	Con Link Extra Max	Transverse Pitch Max	ISO Breaking Load F_B in N Min	Weight kg/m	No 4	No 107	No 26	No 11	
		A	A	B	C	D	E		F	H2	J	K							
115443	40-2	0.50	12.70	7.85	7.92	11.7	1.80	1.50	3.97	31.3	1.9	14.38	27800	1.29	✓	✓	✓	✓	
115453	50-2	0.625	15.875	9.40	10.16	14.6	2.42	2.00	5.08	39.2	2.5	18.11	43600	2.15	✓	✓	✓	✓	
115463	60-2	0.75	19.05	12.57	11.91	17.5	3.23	2.40	5.95	49.8	2.5	22.78	62600	3.27	✓	✓	✓	✓	
115483	80-2	1.00	25.40	15.75	15.88	23.0	4.06	3.00	7.92	63.0	3.0	26.11	111200	5.59	✓	✓	✓	✓	
115503	100-2	1.25	31.75	18.90	19.05	25.3	4.40	4.00	9.53	76.4	3.5	29.29	174000	7.00	✓	✓	-	✓	

N.B. Renold Syno does not conform exactly to BS/ANSI standards. A larger bush and thus a smaller pin diameter are needed to meet the high performance requirements. However, all gearing dimensions of Renold Syno do comply with BS/ANSI standards. Consult Renold for specific requirements.

Triplex sizes available on request. Duplex Syno fits standard duplex sprockets.

These are minimum breaking loads. RENOLD does not consider breaking load to be a good indicator of performance, as it overlooks the principal factors of wear and fatigue.



No.4



No.107



No.11



No.26

For higher loads and more heavy-duty applications, the Renold Syno Polymer Bush range takes on the serious business of wear and fatigue resistance through the addition of a polymer sleeve between the pin and bush. This highly durable and wear resistant polymer – specifically developed for Renold – as well as a polymer roller that has been tested for impact resistance and load capabilities means that the chain can be operated without any lubrication. Available in ANSI 120 to 200 and ideal for applications where it is not possible or not advisable to lubricate a chain, Renold Syno Polymer Bush chain can be considered for:



- Outdoor or wash down environments
- Environments where lubrication may contaminate products
- Environments where lubrication may cause contaminants to stick to the chain and possibly get into bearing areas, seizing up the chain
- Car assembly plants or steel mills
- Forestry, saw mills or paper mills
- Textile plants
- Mixers

With a corrosion resistant surface treatment adding to the variety of applications it can cope with, Renold Syno Polymer Bush chain is a truly versatile product

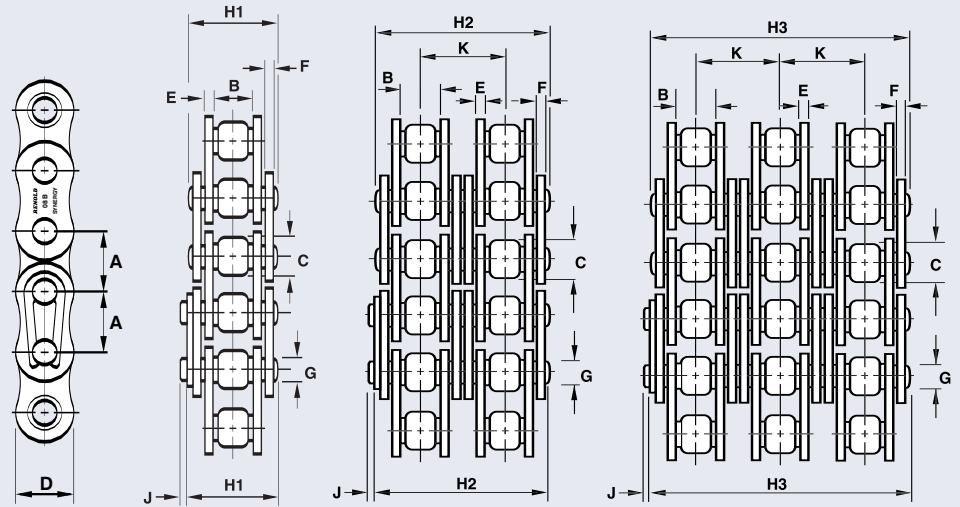

ANSI Standard Syno Polymer Bush

Chain No	ISO No	Technical Details (mm)											ISO Breaking Load F _B in N Min	Mass with polymer roller kg/m	Connecting Links			
		Pitch Inch	Pitch mm	Inside Width Min	Roller Dia Max	Plate Height Max	Plate Width Inner Max	Plate Width Outer Max	Pin Dia Max	Pin Len Max	Con Link Extra Max	Transverse Pitch Nom			No 11	No 107	No 58	
		A	A	B	C	D	E	F	G	H1	J							
529127	120-1	1.5	38.1	25.23	22.23	36.20	4.80	4.80	11.11	49.3	5.3	-	125000	5.0	✓	✓	✓	
529143	140-1	1.75	44.45	25.23	25.4	42.23	5.61	5.61	12.71	52.9	5.2	-	170000	6.9	✓	✓	✓	
529163	160-1	2.0	50.8	31.55	28.58	48.26	6.35	6.35	14.29	63.1	6.5	-	223000	9.2	✓	✓	✓	
529203	200-1	2.5	63.5	37.85	39.67	60.33	8.13	8.13	19.85	76.9	9.0	-	347000	15.0	✓	✓	✓	

ANSI Standard Syno Polymer Bush - Duplex

Chain No	ISO No	Technical Details (mm)											ISO Breaking Load F _B in N Min	Mass with polymer roller kg/m	Connecting Links			
		Pitch Inch	Pitch mm	Inside Width Min	Roller Dia Max	Plate Height Max	Plate Width Inner Max	Plate Width Outer Max	Pin Dia Max	Pin Len Max	Con Link Extra Max	Transverse Pitch Nom			No 11	No 107	No 58	
		A	A	B	C	D	E	F	G	H1	J							
525127	120-2	1.5	38.1	25.23	22.23	36.20	4.80	4.80	11.11	94.7	5.3	45.44	250000	9.6	✓	✓	✓	
525143	140-2	1.75	44.45	25.23	25.4	42.23	5.61	5.61	12.71	101.8	5.2	48.87	340000	13.7	✓	✓	✓	
525163	160-2	2.0	50.8	31.55	28.58	48.26	6.35	6.35	14.29	121.6	6.5	58.55	446000	18.2	✓	✓	✓	
525203	200-2	2.5	63.5	37.85	39.67	60.33	8.13	8.13	19.85	148.5	9.0	71.55	694000	29.8	✓	✓	✓	



No. 107



No. 11/58

RENOLD Stainless Steel Chain

1

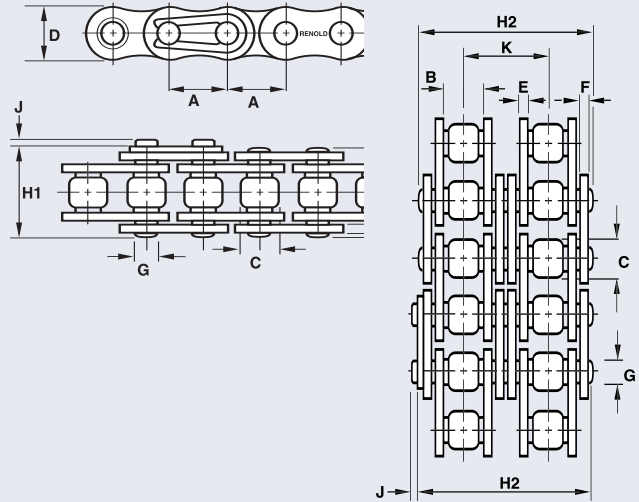

Renold roller chain is manufactured using Class 300 Series stainless steel specification. These chains are ideal for acidic or alkaline environments, or where the chain will be exposed to water, and for very high or very low temperature locations, where resistance to corrosion is a requirement.

Renold chain should be selected when resistance to chemical action is critical. Renold is manufactured using FDA approved material and is prelubricated with USDA H1 approved lubricant.

Renold Stainless Steel ANSI - Simplex

Chain

Technical Details

Connecting Links

ANSI No	Pitch	Pitch	Inside	Roller	Plate	Plate	Plate	Pin	Pin	Con	Trans	Breaking Load F _B Newtons Min	Weight kg/m	No	No	No	No	No	No
	Inch	mm	Width Min	Dia Max	Height Max	Width Inner	Width Outer Max	Dia Max	Len Max	Link Extra	Pitch Max Max			4	107	11	26	12	30
	A	A	B	C	D	E	F	G	H1	J	K								
40	0.50	12.7	7.85	7.92	11.15	1.55	1.55	3.98	17.8	3.9	-	10690	0.63	✓	✓	✓	✓	✓	✓
50	0.625	15.875	9.4	10.16	14.55	2.03	2.03	5.07	21.8	4.1	-	16810	1.05	✓	✓	✓	✓	✓	✓
60	0.75	19.05	12.58	11.91	17.45	2.39	2.39	5.96	26.9	4.6	-	24030	1.55	✓	✓	✓	✓	✓	✓
80	1.00	25.4	15.75	15.88	24.05	3.25	3.25	7.93	33.5	5.4	-	51000	2.80	✓	✓	✓	-	✓	-

Renold Stainless Steel ANSI - Duplex

Chain

Technical Details

Connecting Links

ANSI No	Pitch	Pitch	Inside	Roller	Plate	Plate	Plate	Pin	Pin	Con	Trans	Breaking Load F _B Newtons Min	Weight kg/m	No	No	No	No	No	No
	Inch	mm	Width Min	Dia Max	Height Max	Width Inner	Width Outer Max	Dia Max	Len Max	Link Extra	Pitch Max Max			4	7	11	26	12	30
	A	A	B	C	D	E	F	G	H2	J	K								
40-2	0.5	12.7	7.75	8.51	11.7	1.8	1.5	3.97	30.8	1.5	14.38	23430	1.38	✓	✓	✓	✓	-	-
50-2	0.625	15.87	9.65	10.16	14.6	2.0	2.0	4.45	37.0	2.4	18.11	29430	1.80	✓	✓	✓	✓	-	-
60-2	0.75	19.05	11.68	12.07	16.7	2.4	2.4	5.08	44.8	2.2	22.78	37280	2.40	✓	✓	✓	✓	-	-
80-2	1.0	25.4	17.02	15.88	21.0	4.0	3.2	8.27	61.3	5.4	29.29	101000	5.00	✓	✓	✓	✓	-	-



No.4



No.107



No.11



No.26



No.12



No.30

Renold Hydro-Service® chains are treated with a mechanical zinc plating process with additional coatings applied for extra corrosion protection. The corrosion resistance of this coating in many wet, humid, saltwater or other moisture-related applications is far superior to standard nickel or zinc plating. Unlike some products treated in a similar way for corrosion resistance, Renold Hydro-Service® chain is hexavalent chrome-free, ensuring that it is safe and also environmentally friendly. This coating can be applied to standard or adapted, BS or ANSI chain. All components of the Hydro-Service® chain are treated prior to assembly in order to achieve full coverage and protection to all vital surfaces, not just those visible external surfaces. This helps to improve chain wear life and protect against corrosion-related pin and bush failures. Unlike nickel or zinc platings, the Hydro-Service® treatment will not chip or peel. This extremely durable coating will continue to provide exceptional protection where other treatments fail.

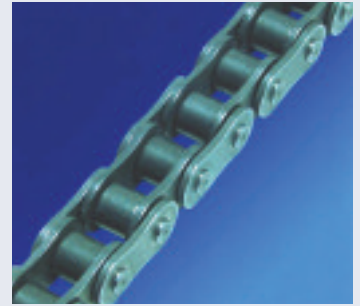

1

Product features include:

- Excellent corrosion resistance
- Hexavalent chrome-free
- More than 30 times the corrosion protection compared with conventional surface treatments
- No hydrogen embrittlement failures
- More economical than stainless steel chain
- Same strength and working load values as standard carbon steel chain

Potential applications:

- Sea water environments
- Meat and poultry processing plants
- Vegetable processing plants
- Seafood processing plants
- Beverage plants
- Washdown equipment
- Outdoor applications

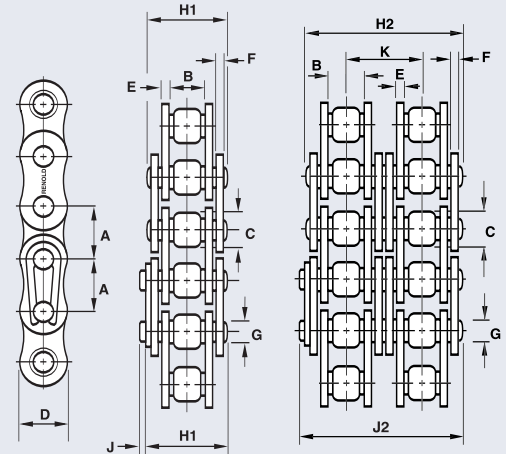

Hydro-Service ANSI base chain data - Simplex

Chain		Technical Details											Connecting Links								
Renold Chain No	ISO No	Pitch Inch	Pitch mm	Inside Width Min	Roller Dia Max	Plate Height Max	Plate Width Inner Max	Plate Width Outer Max	Pin Dia Max	Pin Len Max	Con Link Extra Max	Trans Pitch	Breaking Load F _B Newtons Min	Weight kg/m	No 4	No 107	No 11	No 58	No 12	No 26	No 30
		A	A	B	C	D	E	F	G	H1	J	K									
539023	25-1	0.25	6.35	3.1	3.3	6.02	0.76	0.76	2.3	8.6	0.8	-	3500	0.13	✓	✓	-	-	-	✓	✓
539033	35-1	0.375	9.525	4.68	5.08	9.05	1.3	1.3	3.59	12.0	1.1	-	7900	0.33	✓	✓	-	-	✓	✓	✓
539043	40-1	0.5	12.7	7.85	7.92	12.07	1.55	1.55	3.98	16.4	1.4	-	13900	0.6	✓	✓	✓	-	✓	✓	✓
539053	50-1	0.625	15.875	9.4	10.16	15.09	2.03	2.03	5.09	20.4	1.1	-	21800	1.0	✓	✓	✓	-	✓	✓	✓
539063	60-1	0.75	19.05	12.57	11.91	18.1	2.39	2.39	5.96	25.3	1.1	-	31300	1.47	✓	✓	✓	-	✓	✓	✓
539083	80-1	1.0	25.4	15.75	15.88	24.13	3.25	3.25	7.94	32.7	3.0	-	55600	2.8	✓	✓	✓	✓	✓	-	-
539103	100-1	1.25	31.75	18.9	19.05	30.17	4.06	4.06	9.54	39.7	4.2	-	87000	4.2	✓	✓	✓	✓	✓	-	-
539123	120-1	1.5	38.1	25.23	22.23	36.2	4.8	4.8	11.11	49.3	5.3	-	125000	5.7	✓	✓	✓	✓	✓	-	-

Hydro-Service ANSI base chain data - Duplex

Chain		Technical Details											Connecting Links								
Renold Chain No	ISO No	Pitch Inch	Pitch mm	Inside Width Min	Roller Dia Max	Plate Height Max	Plate Width Inner Max	Plate Width Outer Max	Pin Dia Max	Pin Len Max	Con Link Extra Max	Trans Pitch	Breaking Load F _B Newtons Min	Weight kg/m	No 4	No 107	No 11	No 58	No 12	No 26	No 30
		A	A	B	C	D	E	F	G	H2	J	K									
535023	25-2	0.25	6.35	3.1	3.3	6.02	0.76	0.76	2.3	15.5	0.8	6.4	7000	0.26	✓	✓	-	-	-	✓	✓
535033	35-2	0.375	9.525	4.68	5.08	9.05	1.3	1.3	3.59	22.2	1.1	10.13	15800	0.65	✓	✓	-	-	✓	✓	✓
535043	40-2	0.5	12.7	7.85	7.92	12.07	1.55	1.55	3.98	30.8	1.4	14.38	27800	1.2	✓	✓	✓	-	✓	✓	✓
535053	50-2	0.625	15.875	9.4	10.16	15.09	2.03	2.03	5.09	38.4	1.1	18.11	43600	2.1	✓	✓	✓	-	✓	✓	✓
535063	60-2	0.75	19.05	12.57	11.91	18.1	2.39	2.39	5.96	48.1	1.1	22.78	62600	3.05	✓	✓	✓	-	✓	✓	✓
535083	80-2	1.0	25.4	15.75	15.88	24.13	3.25	3.25	7.94	61.9	3.0	29.29	111200	5.5	✓	✓	✓	✓	✓	-	-
535103	100-2	1.25	31.75	18.9	19.05	30.17	4.06	4.06	9.54	75.4	4.2	35.76	174000	8.4	✓	✓	✓	✓	✓	-	-
535123	120-2	1.5	38.1	25.23	22.23	36.2	4.8	4.8	11.11	94.7	5.3	45.44	250000	11.0	✓	✓	✓	✓	✓	-	-



RENOLD ANSI Xtra Chain

RENOLD ANSI XTRA...

1

Xtra shock resistant pins

Xtra round components with seamless roller/bush

Xtra finish shot peening ball drifting

Xtra security interference fits

Xtra thick plates resists heavy loads



Shock resistant



Fatigue resistant



High loads

... THE HEAVY DUTY CHAIN

Product Description

RENOLD ANSI XTRA chain incorporates the usual Renold performance enhancing features including seamless bushes, ball drifted plate holes, shot peening and optimum interference fits. The extra features incorporated into this range of chain is classified by:

- Thicker side plates denoted by 'H'. These plates are approximately 20% thicker than standard ANSI chain.

- Through hardened pins, denoted by 'V'.

The gearing dimensions of ANSI XTRA chain are identical to our standard ANSI simplex range and will therefore run on standard sprockets. The larger transverse pitch of duplex and triplex chains with heavy duty side plates (H or HV range) require special sprockets.

The range can therefore be summarised as follows:

H Range - Identical to standard ANSI chain with the exception of the overall width. Thicker plates give this chain excellent resistance to heavy loads and help absorb shock. Duplex and triplex chain must have sprockets with an increased transverse pitch of the teeth.

V Range - Identical dimensions to standard ANSI chain but with a higher breaking load and excellent resistance to shock loads.

HV Range - A combination of the 'H' and 'V' chain, giving excellent resistance to both heavy and shock loads.

A further enhancement to the chain life can be achieved by hardening the sprocket teeth of the drive. 'H' and 'HV' chains are designed for improved fatigue life, therefore offset and slip fit joints which have a lower fatigue resistance are not recommended.

Shown below is an easy to use features guide to help in selecting chain to suit its application.

Chain Type	Strength	Wear	Heavy Loads	Shock Loads	High Speeds
Standard ANSI	Good	Excellent	Good	Good	Excellent
XTRA H Range	Good	Excellent	Excellent	Good	Not Suitable
XTRA V Range	Excellent	Good	Good	Excellent	Good
XTRA HV Range	Excellent	Good	Excellent	Excellent	Not Suitable

ANSI XTRA roller chain is specifically designed and manufactured for arduous applications where frequent, impulsive or heavy loads are involved, or where operating conditions are severe as in the mining, quarrying, rock drilling, forestry and construction industries. This chain is interchangeable with our standard ANSI range and can be used to upgrade the performance of existing applications subject to normal design and installation checks.

Multiplex versions are also available on request.

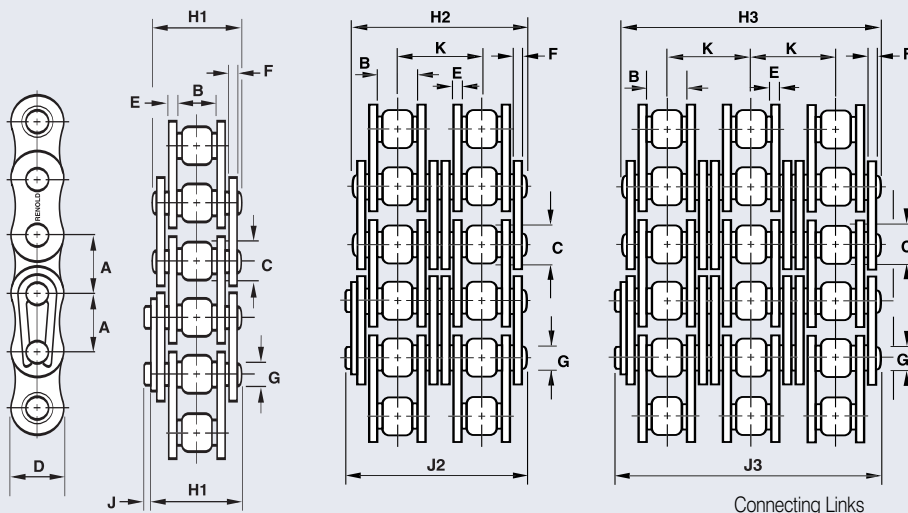

Chain No	ANSI No	Pitch Inch	Pitch mm	Inside Width Min	Roller Dia Max	Plate Height Max	Plate Width Inner Max	Plate Width Outer Max	Pin Dia Max	Pin Len Max	Con Link Extra Max	Transverse Pitch Max	ISO 606 Tensile Strength Min	Weight kg/m	No. 4	No. 107	No. 26	No. 11/58
		A	A	B	C	D	E	F	G	H1	J	K						

H - Series Simplex

187661	60H-1	0.75	19.05	12.57	11.91	17.5	3.17	3.17	5.94	28.6	4.6	-	40000	1.8	✓	✓	-	✓
189531	80H-1	1.0	25.4	15.75	15.88	24.05	4.06	4.06	7.93	37.0	5.4	-	70000	3.3	✓	✓	✓	✓
188556	100H-1	1.25	31.75	18.9	19.05	29.97	4.8	4.8	9.54	44.1	6.1	-	104500	4.8	✓	✓	-	✓
188661	120H-1	1.5	38.1	25.23	22.23	35.89	5.61	5.61	11.11	52.53	6.6	-	142000	6.3	✓	✓	-	✓
188716	140H-1	1.75	44.45	25.23	25.4	41.81	6.35	6.35	12.71	57.9	7.4	-	191000	8.6	✓	✓	-	✓
188731	160H-1	2.0	50.8	31.55	28.58	47.73	7.11	7.11	14.29	68.5	7.9	-	244500	11.2	✓	✓	-	✓
188761	180H-1	2.25	57.15	35.48	35.71	53.51	8.13	8.13	17.46	77.94	9.1	-	324700	15.21	✓	✓	-	✓
188781	200H-1	2.5	63.5	37.85	39.67	59.56	9.65	9.65	19.85	86.4	10.2	-	422500	19.5	✓	✓	-	✓

H - Series Duplex

188557	100H-2	1.25	31.75	18.9	19.05	29.97	4.8	4.8	9.54	83.2	6.1	39.09	209000	10.3	✓	✓	-	✓
188717	140H-2	1.75	44.45	25.23	25.4	41.81	6.35	6.35	12.71	106.9	7.4	48.87	382000	16.74	✓	✓	-	✓

HV - Series Simplex

187666	60HV-1	0.75	19.05	12.57	11.91	17.5	3.17	3.17	5.94	28.6	4.6	-	55000	1.8	✓	✓	-	✓
189541	80HV-1	1.0	25.4	15.75	15.88	24.05	4.06	4.06	7.93	37.0	5.4	-	87000	3.3	✓	✓	✓	✓
188566	100HV-1	1.25	31.75	18.9	19.05	29.97	4.8	4.8	9.54	44.1	6.1	-	133450	4.8	✓	✓	-	✓
188671	120HV-1	1.5	38.1	25.23	22.23	35.89	5.61	5.61	11.11	52.53	6.6	-	182400	6.3	✓	✓	-	✓
188726	140HV-1	1.75	44.45	25.23	25.4	41.81	6.35	6.35	12.71	57.9	7.4	-	258000	8.6	✓	✓	-	✓
188741	160HV-1	2.0	50.8	31.55	28.58	47.73	7.11	7.11	14.29	68.5	7.9	-	311400	11.2	✓	✓	-	✓
188771	180HV-1	2.25	57.15	35.48	35.71	53.51	8.13	8.13	17.46	77.94	9.1	-	324700	15.21	✓	✓	-	✓
188791	200HV-1	2.5	63.5	37.85	39.67	59.56	9.65	9.65	19.85	86.4	10.2	-	600500	19.5	✓	✓	-	✓

HV - Series Duplex

188727	140HV-2	1.75	44.45	25.23	25.4	41.81	6.35	6.35	12.71	106.9	7.4	48.87	516000	16.74	✓	✓	-	✓
188742	160HV-2	2.0	50.8	31.55	28.58	47.73	7.11	7.11	14.29	130.4	7.9	61.9	622800	23.5	✓	✓	-	✓

HV - Series Triplex

188568	100HV-3	1.25	31.75	18.9	19.05	29.97	4.8	4.8	9.54	120.78	6.1	39.09	400350	15.45	✓	✓	-	✓
--------	---------	------	-------	------	-------	-------	-----	-----	------	--------	-----	-------	--------	-------	---	---	---	---

V - Series Simplex

189546	80V-1	1.0	25.4	15.75	15.88	24.05	3.25	3.25	7.93	33.5	5.4	-	75000	2.8	✓	✓	-	✓
188576	100V-1	1.25	31.75	18.9	19.05	29.97	4.06	4.06	9.54	41.1	6.1	-	122000	4.2	✓	✓	-	✓
188676	120V-1	1.5	38.1	25.23	22.23	35.89	4.8	4.8	11.11	50.8	6.6	-	169000	5.7	✓	✓	-	✓
188736	140V-1	1.75	44.45	25.23	25.4	41.81	5.61	5.61	12.71	54.9	7.4	-	235000	7.8	✓	✓	-	✓
188746	160V-1	2.0	50.8	31.55	28.58	47.73	6.35	6.35	14.29	65.5	7.9	-	289000	10.4	✓	✓	-	✓
188756	180V-1	2.25	57.15	35.48	35.71	53.51	7.11	7.11	17.46	73.9	9.1	-	382500	13.94	✓	✓	-	✓
188776	200V-1	2.5	63.5	37.85	39.67	59.56	8.13	8.13	19.85	80.3	10.2	-	445000	17.3	✓	✓	-	✓

V - Series Duplex

189547	80V-2	1.0	25.4	15.75	15.88	24.05	3.25	3.25	7.93	62.7	5.4	29.29	150000	5.5	✓	✓	-	✓
188677	120V-2	1.5	38.1	25.23	22.23	35.89	4.8	4.8	11.11	96.3	6.6	45.44	338000	11.0	✓	✓	-	✓
188737	140V-2	1.75	44.45	25.23	25.4	41.81	5.61	5.61	12.71	103.6	7.4	48.87	470000	15.5	✓	✓	-	✓

V - Series Triplex

189548	80V-3	1.0	25.4	15.75	15.88	24.05	3.25	3.25	7.93	91.9	5.4	29.29	225000	8.3	✓	✓	-	✓
188678	120V-3	1.5	38.1	25.23	22.23	35.89	4.8	4.8	11.11	141.7	6.6	45.44	507000	16.7	✓	✓	-	✓
188738	140V-3	1.75	44.45	25.23	25.4	41.81	5.61	5.61	12.71	152.4	7.4	48.87	705000	23.1	✓	✓	-	✓



No.4



No.107



No.26



No.11/58

ANSI Nickel Plated

ISO606 A Series / ANSI B29.100

1

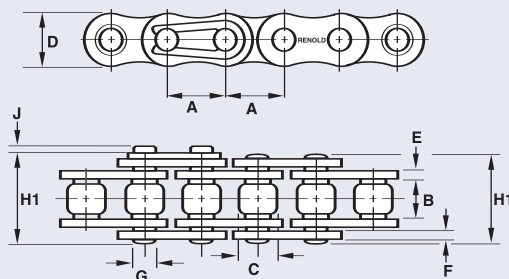

Nickel Plated ANSI Standard - Simplex

Chain

Technical Details

Connecting Links

Renold Chain No	ANSI No	Pitch Inch	Pitch mm	Inside Width Min	Roller Dia Max	Plate Height Max	Plate Width Inner Max	Plate Width Outer Max	Pin Dia Max	Pin Len Max	Con Link Extra Max	Trans Pitch Max	FB Newtons Min	Weight kg/m	No 4	No 107	No 11	No 58	No 12	No 26	No 30
															A	A	B	C	D	E	F
559043	40-1	0.5	12.7	7.85	7.92	11.15	1.55	1.55	3.98	17.8	3.9	-	13900	0.63	✓	✓	✓	-	✓	✓	✓
559053	50-1	0.625	15.88	9.4	10.16	14.55	2.03	2.03	5.07	21.8	4.1	-	21800	1.05	✓	✓	✓	-	✓	✓	✓
559063	60-1	0.75	19.05	12.58	11.91	17.4	2.39	2.39	5.96	26.9	4.6	-	31300	1.55	✓	✓	✓	-	✓	✓	✓
559083	80-1	1.0	25.4	15.75	15.88	24.05	3.25	3.25	7.9	33.5	5.4	-	55600	2.8	✓	✓	✓	✓	✓	-	-
559103	100-1	1.25	31.75	18.9	19.05	29.85	4.06	4.06	9.54	41.1	6.1	-	87000	4.2	✓	✓	✓	✓	✓	-	-

Nickel Plated ANSI Standard - Duplex

555083	80-2	1.0	25.4	15.75	15.88	24.05	3.25	3.25	7.93	62.7	5.4	29.29	111200	5.50	✓	✓	✓	✓	✓	-	-
--------	------	-----	------	-------	-------	-------	------	------	------	------	-----	-------	--------	------	---	---	---	---	---	---	---

.F_B = AXIAL BREAKING FORCE

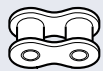

No.4



No.107



No.11/58



No.26



No.12



No.30

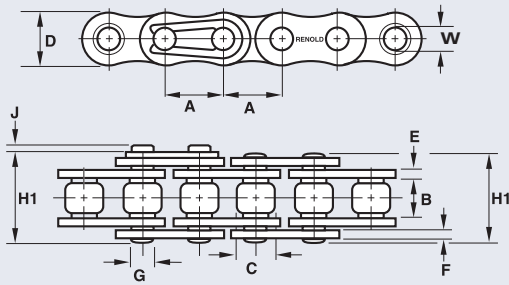

1

ANSI Dimensions

Chain		Technical Details											Connecting Links		
Renold Chain No	ISO No	Pitch Inch	Pitch mm	Inside Width Min	Roller Dia Max	Plate Height Max	Plate Width Inner Max	Plate Width Outer Max	Pin Bore Min	Pin Len Max	Con Link Extra Max	Breaking Load F _B Newtons Min	Weight kg/m	No 4	No 26
		A	A	B	C	D	E	F	W	H1	J				

Simplex - Bush Chain

187121	-	0.625	15.88	9.4	10.16	15.1	2.0	2.0	5.1	20.4	1.0	18000	1.05	✓	✓
187122	-	0.75	19.05	12.7	11.91	17.5	2.4	2.4	6.0	25.3	1.3	28500	1.39	✓	✓
187125	-	1.00	25.4	15.88	15.88	25	2.7	3.7	9.5	34.0	5.1	60000	2.2	✓	✓



No.4



No.107



No.11/58



No.26



No.12



No.30

Double Pitch Chain Simplex

ANSI B29.00 / ISO1275

1

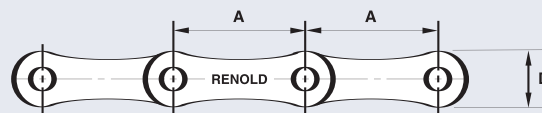
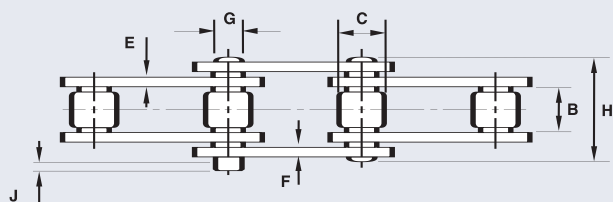

ANSI Standard

Chain

Technical Details

Connecting Links

Product Number	Pitch	Pitch	Inside	Roller	Plate	Inner	Outer	Pin	Pin	Con	Breaking Load F _B Newtons Min	Weight kg/m	No 4	No 107	No 11/58	No 12
	Inch	mm	Width	Dia Thickness	Height Thickness	Plate	Plate	Dia Extra	Len	Link						
	A	A	B	C	D	E	F	G	H	J						

Conveyor Series

Small roller

C2040R	1.0	25.4	7.85	7.92	11.8	1.5	1.5	3.97	17.8	3.9	14100	0.5	✓	✓	✓	✓
C2050R	1.25	31.75	9.4	10.16	15.0	2.0	2.0	5.09	21.8	4.1	22200	0.84	✓	✓	✓	✓
C2060R	1.5	38.1	12.57	11.91	17.8	3.17	3.17	5.95	28.6	4.6	38000	1.44	✓	✓	✓	✓
C2080R	2.0	50.8	15.75	15.88	24.1	4.0	4.0	7.92	35.8	5.4	65000	2.42	✓	✓	✓	✓
C2100H	2.5	63.5	19.0	19.05	28.8	4.75	4.75	9.54	42.4	4.3	137000	3.47	✓	✓	✓	✓
C2120H	3.0	76.2	25.4	22.23	35.1	5.61	5.61	11.11	52.4	5.3	185900	4.93	✓	✓	✓	✓
C2160H	4.0	101.6	31.5	28.58	47.9	7.3	7.3	14.29	65.6	6.7	305500	8.0	✓	✓	✓	✓

Large roller

C2042R	1.0	25.4	7.85	15.88	11.8	1.5	1.5	3.97	17.8	3.9	14100	0.82	✓	✓	✓	✓
C2052R	1.25	31.75	9.4	19.05	15.0	2.0	2.0	5.09	21.8	4.1	22200	1.26	✓	✓	✓	✓
C2062R	1.5	38.1	12.57	22.23	17.8	3.17	3.17	5.95	28.6	4.6	38000	2.03	✓	✓	✓	✓
C2082R	2.0	50.8	15.75	28.58	24.1	4.0	4.0	7.92	35.8	5.4	65000	3.36	✓	✓	✓	✓
C2102H	2.5	63.5	19.0	39.67	28.8	4.75	4.75	9.54	42.4	4.3	137000	5.65	✓	✓	✓	✓
C2122H	3.0	76.2	25.4	44.45	35.1	5.61	5.61	11.11	52.4	5.3	185900	7.9	✓	✓	✓	✓
C2162H	4.0	101.6	31.5	57.15	47.9	7.3	7.3	14.29	65.6	6.7	305500	12.8	✓	✓	✓	✓

Drive Series

A2040	1.0	25.4	7.85	7.92	11.8	1.5	1.5	3.97	17.8	3.9	14100	0.4	✓	✓	✓	✓
A2050	1.25	31.75	9.4	10.16	15.0	2.0	2.0	5.09	21.8	4.1	22200	0.7	✓	✓	✓	✓
A2060	1.5	38.1	12.57	11.91	17.8	2.4	2.4	5.95	26.9	4.6	31800	1.05	✓	✓	✓	✓
A2080	2.0	50.8	15.75	15.88	24.1	3.0	3.0	7.92	33.5	5.4	56700	1.76	✓	✓	✓	✓

F_B = AXIAL BREAKING FORCE



No. 4

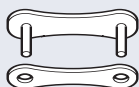

No. 107



No. 11/58

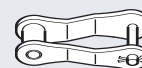

No. 12

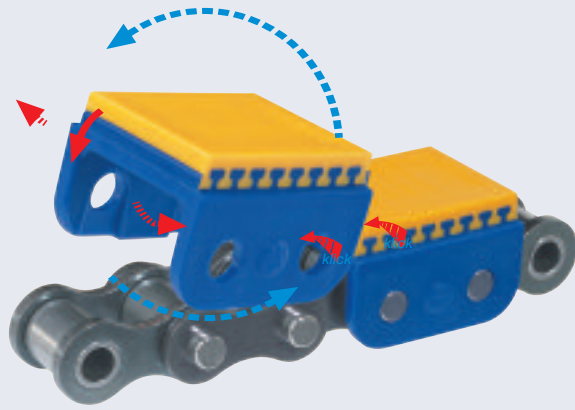

Klik-Top™ polymer block chain is quick to install, strong, suitable for use in hygiene-sensitive areas if required and will cut costly downtime experienced when using conventional polymer block chain.

Klik-Top™ chain ensures reliability, quality and great value for money.

Ideal for conveying delicate items such as glass, wood and packaging.

You can have confidence in Klik-Top™ chain.

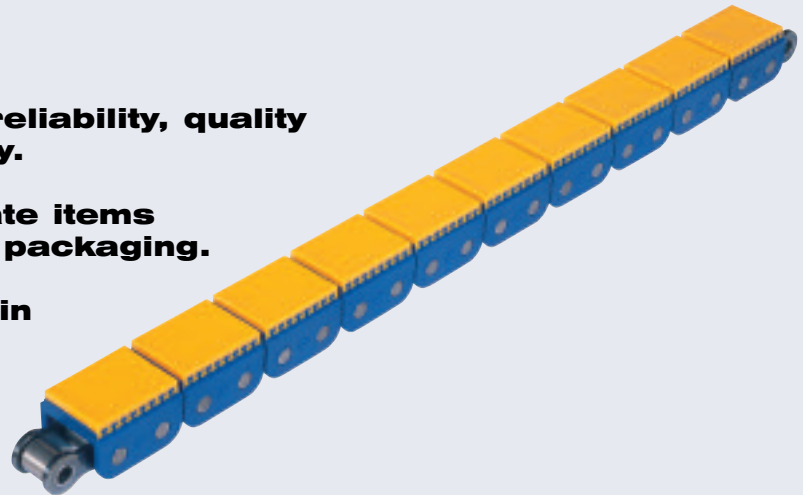

- Short downtimes - increased productivity
- Durable polymer clip
- Easily replaced in moments
- Food industry approved
- Base chain available in stainless steel

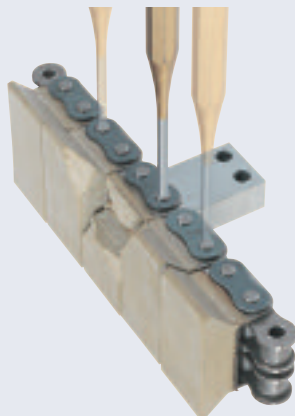

Hard work...isn't it?

- Remove chain
- Grind heads of bearing pins
- Push out bearing pins
- Dismantle damaged parts
- Assemble new spare parts
- Test flexibility
- Reinstall chain

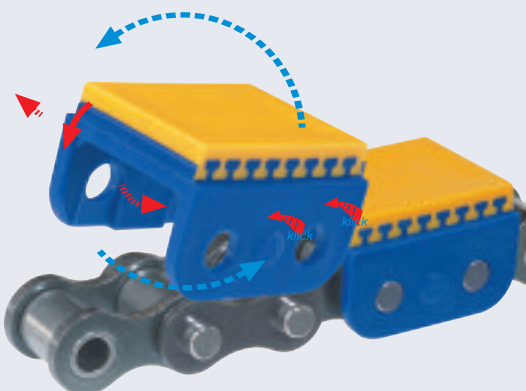

It's easy with Klik-Top™

- Remove damaged clip
- Install new clip

Klik-Top™ Polymer Block Chain

1

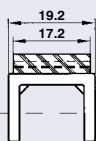
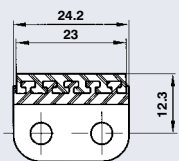

Similar DIN/ISO	A&S No.	Part No. Chain	p x b1	Part No. Connecting link	Part No. clip
08B-1	1603	1210313	1/2" x 5/16"	1317972	1317979
08B-1	1803 RF**	1210314	1/2" x 5/16"	1317973	1317979

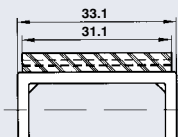
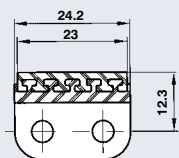

Similar DIN/ISO	A&S No.	Part No. Chain	p x b1	Part No. Connecting link	Part No. clip
08B-2	1603-2	1210315	1/2" x 5/16"	1317974	1317980
08B-2	1603-2 RF**	1210316	1/2" x 5/16"	1317975	1317980

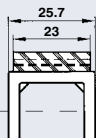
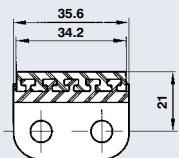

Similar DIN/ISO	A&S No.	Part No. Chain	p x b1	Part No. Connecting link	Part No. clip
12B-1	1642	1210317	3/4" x 7/16"	1317976	1317981
12B-1	1642 RF**	1210318	3/4" x 7/16"	1317977	1317981

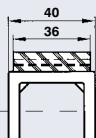
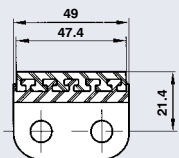

Similar DIN/ISO	A&S No.	Part No. Chain	p x b1	Part No. Connecting link	Part No. clip
16B-1	1666	1209754	1" x 0,67"	1317165	1317164
16B-1	1666 RF**	1210319	1" x 0,67"	1317978	1317164

** RF = The chain is made of rustproof and acid-resistant materials
The dimensions of the chain are similar to those of the DIN standard.
Please take the exact dimensions from the drawings.

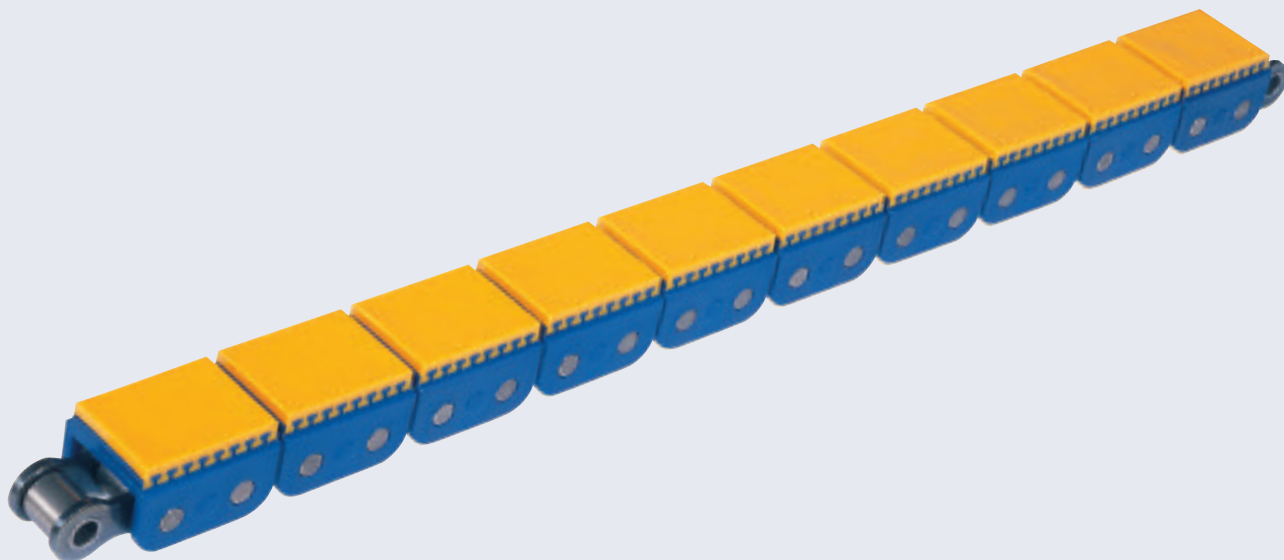

Polymer Block Chain

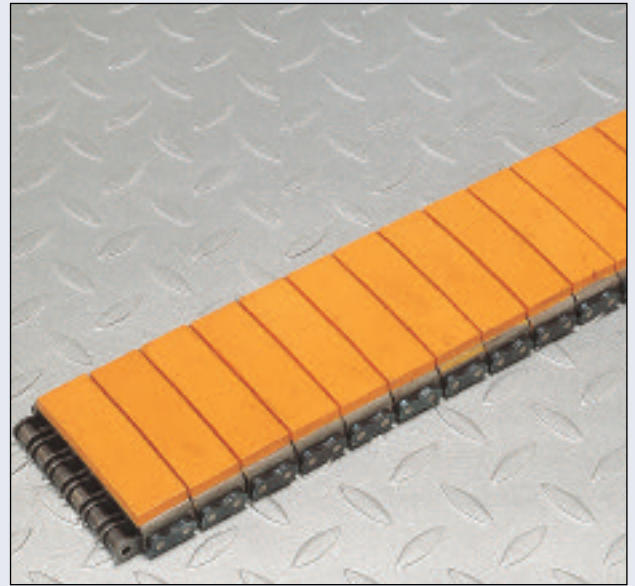

Renold Polymer Block Chain (Rubber Block Chain) has been specifically designed for use in the FEED, CONVEYING and on WORK DISCHARGE types of applications, where an undamaged surface finish is an essential requirement for your finished product.

Renold Chain has been running successfully in all types of machinery and sectors of industry. Examples being:

- WOODWORKING
- FURNITURE INDUSTRY
- PROFILE GRINDING
- BOOK BINDING
- CONVEYING PLASTIC TUBES
- GLASS HANDLING
- CABLE MANUFACTURE
- CONVEYING OF FRAGILE COMPONENTS

The chain is based on ISO, DIN and ANSI standard, both Simplex and Duplex, the only difference being the overall pin length. Polymer block chain can be used in many different environments by simply changing the block material. The most popular chain in this catalogue being available from stock.

The polymer block vulcanised onto the U-plate is wear resistant and has a shore hardness of 50 to 60. It is suitable for working temperatures up to a maximum of 80°C (176°F).

- Polymer block chain is only supplied in even pitch lengths, including a connecting link.
- Chain can be supplied without polymer blocks, with the standard U-plates fitted to the outer links.
- For a small extra charge chain can be zinc plated, but this will reduce the minimum breaking load of the chain by 10%.
- The gearing dimensions of polymer block chain allows them to run on standard sprockets.

Other sizes of chain and block materials can be supplied, apart from the popular and made to order chain detailed in this catalogue. For special applications Renold multiplex chain, up to sextuplex, have been supplied and used successfully where a wider polymer block platform is required.

Popular Range

Pitch	ISO No.	ANSI No.	Type
0.500"	08B-1	-	SIMPLEX
	08B-2	-	DUPLEX
0.750"	12B-1	-	SIMPLEX
	12B-2	-	DUPLEX
1.000"	-	80	SIMPLEX
	-	80-2	DUPLEX
1.500"	24B-1	-	SIMPLEX

Made to Order Sizes

Pitch	ISO No.	ANSI No.	Type
6mm	04	-	SIMPLEX
0.375"	06B-1	-	SIMPLEX
0.500"	08B-3	-	TRIPLEX
0.625"	10B-2	-	DUPLEX
1.250"	20B-1	-	SIMPLEX

The block material specifications available are shown on page 60.

For assistance with selecting the correct chain size, block type or profile for your application, contact our Technical Sales Department.

Polymer Block

Material Code and Details

Code	Material Type	Shore Hardness	Wear Value DIN 53516 mm3	Colour
NR	Natural Rubber	65 + / - 5	160	RAL1014 Ivory
IR	Isoprene Rubber (Synth. polyisoprene)	-	-	-
SBR	Styrene-Butadiene Rubber	-	-	-
BR	Butadiene Rubber (Polybutadiene)	-	-	-
EPDM	Ethylene-Propylene-Diene Polymer	-	-	-
NBR	Acronitrille Butadiene Rubber	75 + / - 5	160	RAL7034 Yellow-Grey
CR	Chloroprene Rubber (Polychloroprene)	65 + / - 5	160	RAL1021 Cadmium-Yellow
AU	Polyester Urethane Rubber	-	-	-
SI	Silicone Resins	70 + / - 5	160*	RAL3012 Beige-Red
FSI	Fluoric Silicone Resins	-	-	-
FPM	Fluoropolymers	75 + / - 5	160*	RAL8008 Olive-Brown
PUR	Polyurethane	85 + / - 5	80	RAL1007 Chrome-Yellow Transparent
PTFE	Poltetrafluoroethylene	-	-	-

- DETAILS AVAILABLE ON REQUEST * RENOLD DESIGN

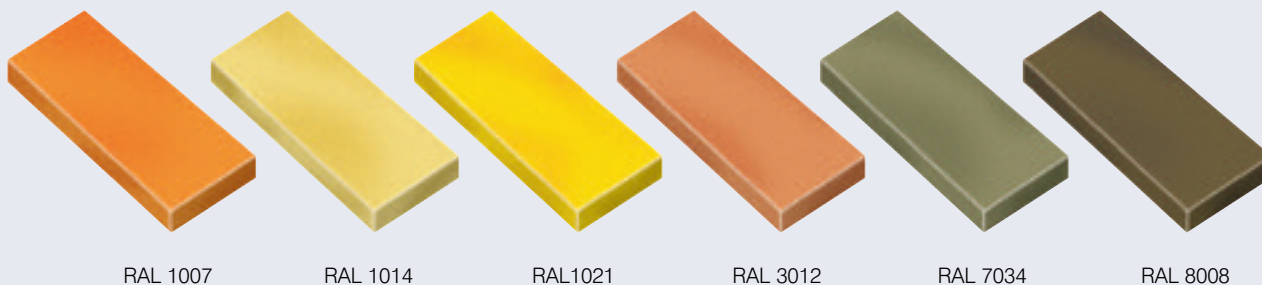

A customer specific design, hardness and wear specification of block is possible, but may be subject to minimum order quantities. Polymer Block material colour may vary from the represented colours shown above.

Material Mechanical Values/Resistance

Type	Material													
	NR	IR	SBR	BR	IIR	EPDM	NBR	CR	AU	SI	FSI	FPM	PUR	PTFE
Tensile Strength	1	2	5	6	4	5	5	3	2	6	6	5	1	1
Elongation at Fracture	1	1	2	3	2	3	2	2	2	4	4	3	2	3
Rebond Resilience	2	2	3	1	6	3	3	3	3	3	3	5	2	NA
Wear Resistance	2	2	2	1	3	3	2	2	1	5	5	4	1	3
Tear Strength	2	3	3	5	4	4	4	3	4	6	6	3	1	2
Current Flow Resistance	1	1	2	2	2	2	4	3	3	1	1	4	2	1
Temperature Hot -Air Degrees C	+90	+90	+100	+100	+140	+150	+130	+120	+120	+200	+200	+220	+80	+260
Minimum Temperature Degrees C	-50	-40	-40	-60	-40	-40	-40	-30	-20	-80	-80	-25	-35	-190
Age Resistance	3	3	3	3	2	1	3	2	2	1	1	1	1	1
Ozone Resistance	4	4	4	3	2	1	3	2	2	1	1	1	1	1
Benzine Resistance	6	6	4	5	6	5	1	2	1	5	1	1	2	1
Oil and Grease Resistance	6	6	5	6	6	4	1	2	1	1	1	1	2	1
Acid Resistance	3	3	3	3	2	1	4	2	5	5	4	1	6	1
Alkali Resistance	3	3	3	3	2	2	3	2	5	5	4	1	6	1
Resistance to Hot Water	3	3	2	3	1	2	3	3	5	5	4	2	6	1

1 = EXCELLENT 2 = VERY GOOD 3 = GOOD 4 = MODERATE 5 = POOR 6 = INSUFFICIENT

When choosing the material for your application, the table above can be used to select the material with the most appropriate properties. For example, where an application has oil and grease present, NBR, AU, SI, FSI FPM and PTFE materials are suitable.

Contact our technical staff for more advice on the suitability of the materials shown.

Simplex Roller Chain

Type Number	Profile without Blocks	Chain No. NR	NBR	Chain Fitted with Material Type		SI	
				PUR	FPM		
Based on 08B-1	1850	1208770	-	-	-	-	-
0.500" Pitch	0520	-	MIN	1208781	MIN	ENQ	MIN
1870	-	MIN	MIN	MIN	ENQ	ENQ	
2720	-	MIN	MIN	TR	ENQ	ENQ	
2750	-	MIN	1208782	MIN	ENQ	ENQ	
4740	-	MIN	1208783	TR	ENQ	ENQ	
5800	-	MIN	1208784	TR	ENQ	ENQ	
Based on 12B-1	5130	1208775	-	-	-	-	-
0.750" Pitch	4680	-	MIN	1208788	TR	ENQ	ENQ
5350	-	MIN	MIN	TR	ENQ	ENQ	
Based on ANSI 80	0641	1208779	-	-	-	-	-
1.000" Pitch	0570	-	MIN	1208792	TR	ENQ	ENQ
1120	-	MIN	MIN	TR	ENQ	ENQ	
1300	-	MIN	1208793	TR	ENQ	ENQ	
1310	-	TR	TR	MIN	TR	TR	
Based on 24B-1	0839	12058788	-	-	-	-	-
1.500" Pitch	0830	-	MIN	MIN	TR	ENQ	ENQ

Duplex Roller Chain

Type Number	Profile without Blocks	Chain No. NR	NBR	Chain Fitted with Material Type		SI	
				PUR	FPM		
Based on 08B-2	0800	1208771	-	-	-	-	-
0.500" Pitch	0530	-	1208785	MIN	MIN	MIN	MIN
0540	-	MIN	MIN	TR	ENQ	ENQ	
0560	-	MIN	MIN	TR	ENQ	ENQ	
0590	-	MIN	MIN	TR	ENQ	ENQ	
0610	-	MIN	MIN	TR	ENQ	ENQ	
0660	-	MIN	1208786	MIN	ENQ	ENQ	
0810	-	MIN	MIN	TR	ENQ	ENQ	
0820	-	MIN	MIN	TR	ENQ	ENQ	
0910	-	MIN	MIN	TR	ENQ	ENQ	
1360	-	MIN	MIN	TR	ENQ	ENQ	
1760	-	MIN	MIN	MIN	ENQ	ENQ	
2020	-	MIN	MIN	TR	ENQ	ENQ	
2520	-	MIN	1208787	TR	ENQ	ENQ	
Based on 12B-2	0639	1208776	-	-	-	-	-
0.750" Pitch	0630	-	MIN	1208789	TR	ENQ	ENQ
0760	-	MIN	1208790	MIN	ENQ	MIN	
1480	-	MIN	MIN	TR	ENQ	ENQ	
Based on ANSI 80-2	0510	1208780	-	-	-	-	-
1.000" Pitch	0570	-	MIN	TR	TR	TR	TR
1120	-	TR	TR	TR	TR	TR	
1300	-	TR	TR	TR	TR	TR	
1310	-	TR	TR	TR	TR	TR	

Key

MIN = MADE TO ORDER ONLY. MINIMUM ORDER QUANTITY OF 100M
 TR = A TOOLING CHARGE WOULD BE APPLIED. MINIMUM ORDER QUANTITY OF 100M
 ENQ = MADE TO ORDER ONLY. ENQUIRE FOR MINIMUM ORDER QUANTITY

PROFILE DRAWINGS AND DIMENSIONS ARE SHOWN ON PAGES 62 AND 63.

Polymer Block Chain

0.500" PITCH SIMPLE CHAIN PROFILES

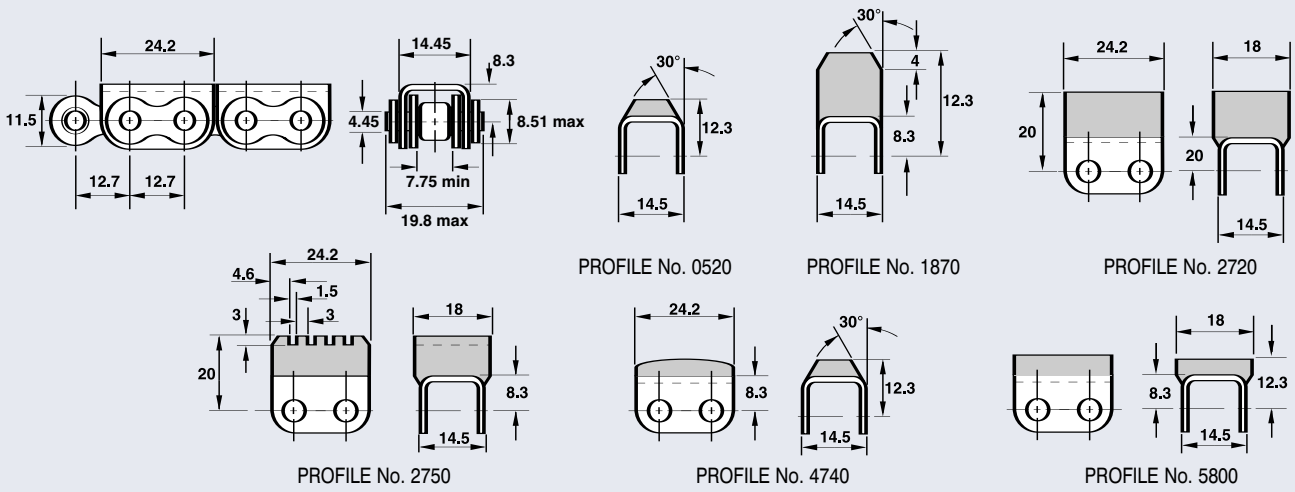

0.750" PITCH SIMPLE CHAIN PROFILES

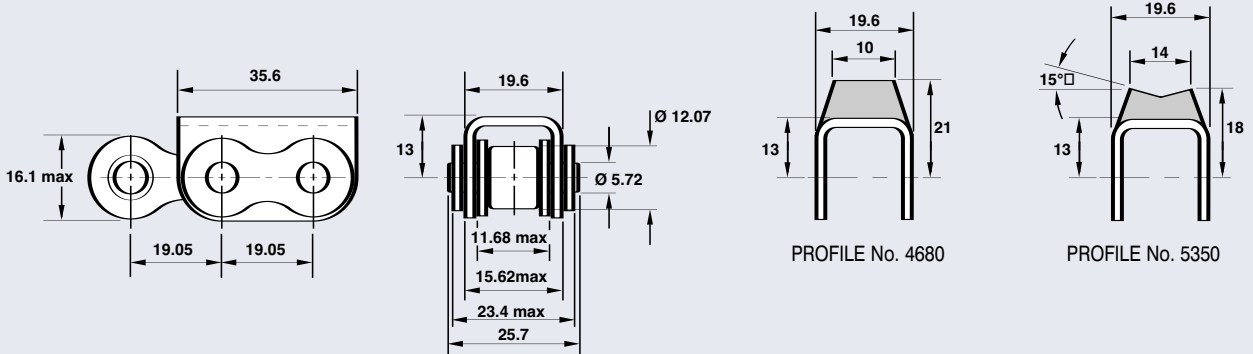

1.000" PITCH SIMPLE CHAIN PROFILES

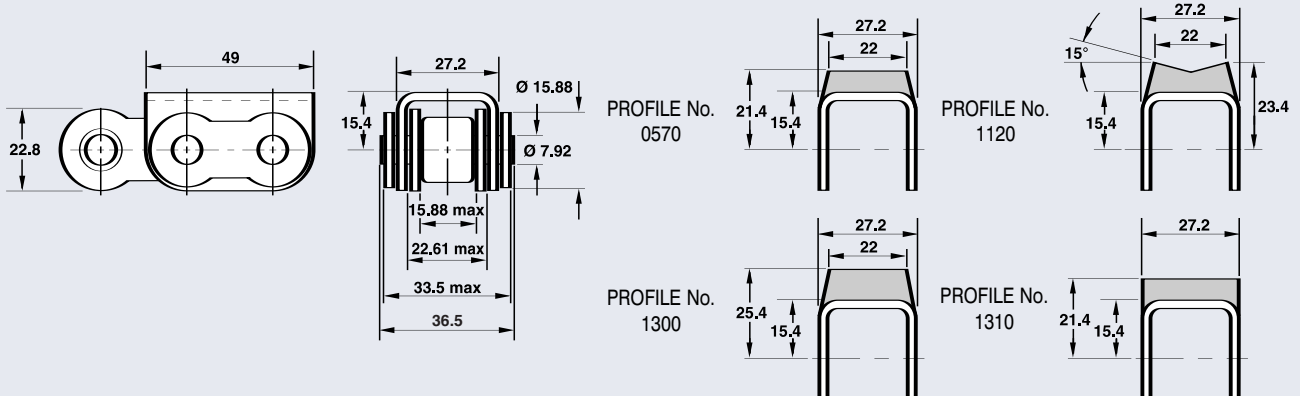

1.500" PITCH SIMPLE CHAIN PROFILES

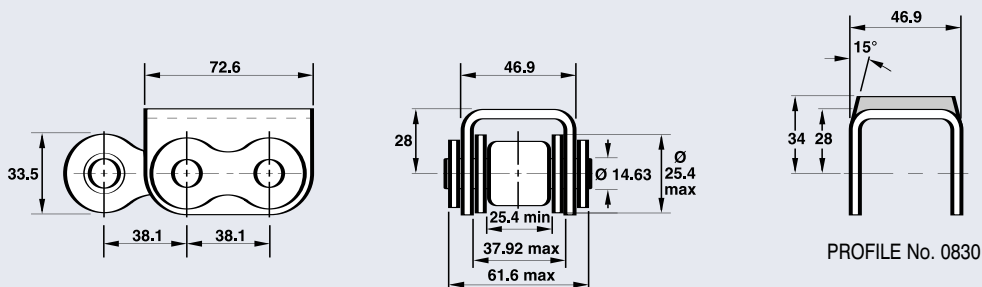

0.500" PITCH DUPLEX CHAIN PROFILES

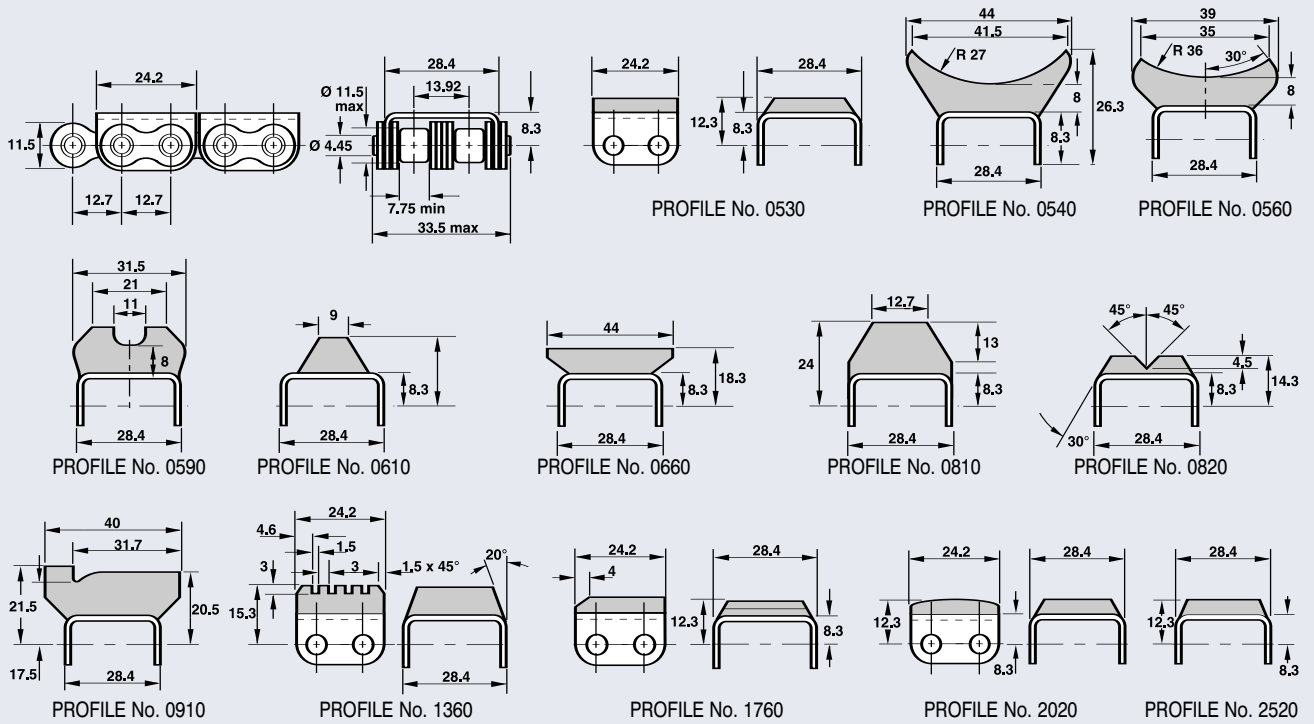

0.750" PITCH DUPLEX CHAIN PROFILES

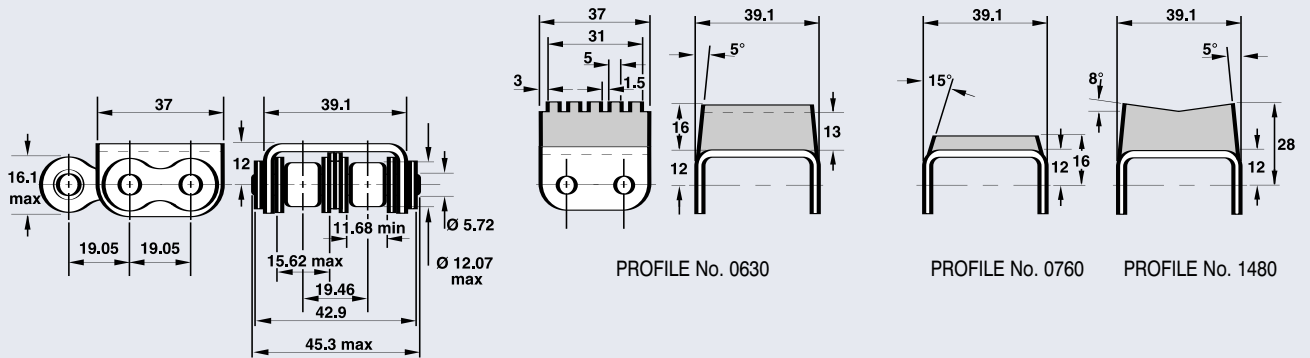

1.000" PITCH DUPLEX CHAIN PROFILES

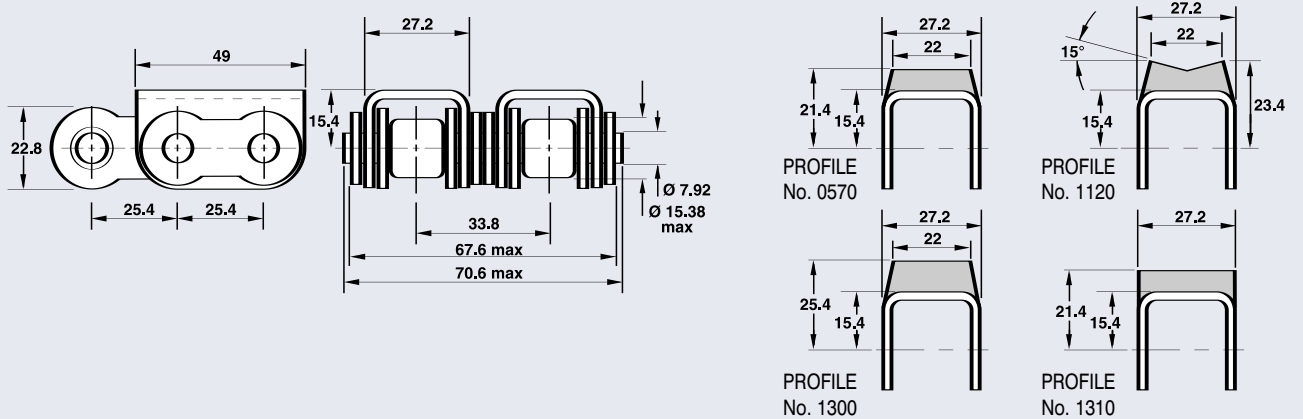

RENOLD Roll-Ring®

Self Adjusting Chain Tensioner

1

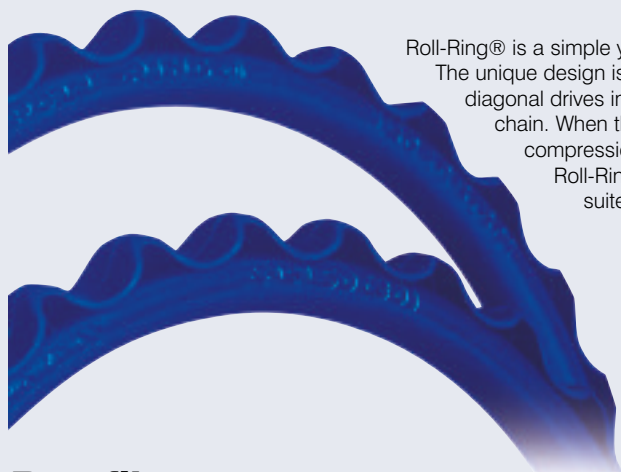

Roll-Ring® is a simple yet innovative chain tensioner made from a specially formulated polymer. The unique design is based upon a simple toothed ring that can be fitted to horizontal, vertical or diagonal drives in a matter of seconds, simply by placing it in-between the two strands of chain. When the drive is in use, the Roll-Ring® deforms to an elliptical shape, due to compression between the strands and completely absorbs any slack in the system. Roll-Ring® performs the job of a tensioner and a damper in one, and is ideally suited to applications where maintenance is difficult or impossible.

Benefits

The Roll-Ring® chain tensioner provides cost effective, time saving installation and maintenance.

The advantages over other types of chain tensioners are:

- Free standing - no sprockets, bolts, plates, drilling or costly installation required.
- The Roll-Ring® is easily installed where space limitations prohibit the use of conventional chain tensioners.
- The Roll-Ring® is fitted in a matter of seconds.
- It is ready for use without any tools, tensioning equipment or any further alignment or adjustment.
- It is fully effective in vertical and diagonal drives.
- The Roll-Ring® works automatically, is maintenance free and self lubricating.
- It can be used in dusty and dirty environments.
- The Roll-Ring® is a tensioner and damper in one, thus reducing noise levels.
- Roll-Ring® also works in reverse mode.

Roll-Ring® chain tensioners reduce chain wear and improve the quality and efficiency of the complete chain drive.



Snap-in installation

The innovative Tensioner

The Roll-Ring® chain tensioner is an elementary mechanism based on new principles and represents a major advance in technology:

- Roll-Ring® requires minimal technical effort.
- Its operation is astonishingly simple.
- All functions are integrated into a single component.
- Roll-Ring® utilises the hollow space of the associated chain drive system giving greater flexibility to designers and specifiers.
- Automatic positioning and self lubricating.

Technical Details

Roll-Ring® chain tensioners provide tensioning using:

- Static tensioning force from the elastic ring
- Dynamic tensioning force from the damping of the working material

Roll-Ring® provides as much tensioning as possible at low chain speeds, and has reserves of tensioning and damping capability for higher chain speeds. The diagram below shows the tensioning force of a Roll-Ring® chain tensioner with its individual allocations of tensioning force and their resulting effects.

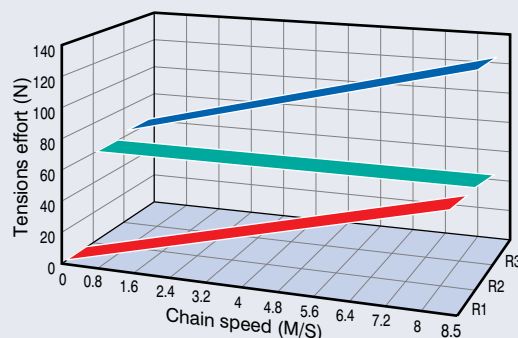

Tensioning effort for ROLL-RING®: Dynamic force R1 (red), Static force R2 (green), Resultant force R3 (blue)

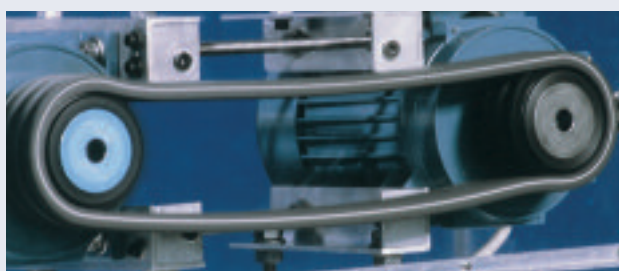

Vibrations in an untensioned chain drive

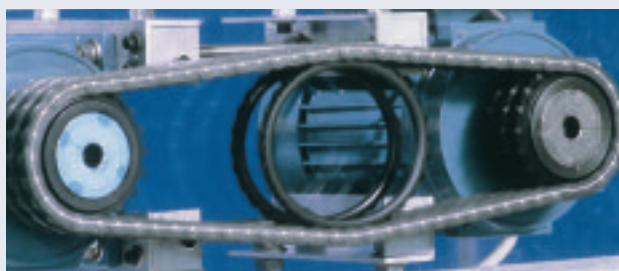

The Roll-Ring® chain tensioner tensions and dampens

Self Adjusting Chain Tensioner

1

Case Study: Chocolate Production

A major chocolate manufacturer was experiencing serious problems with short chain life on a main production line and also had chain tensioning problems, due to the inaccessibility of the chain drives. Firstly, the short chain life (4-5 weeks) was overcome when the Renold Engineer recommended a change to Renold brand, nickel plated chains, which has led to a new chain life of twelve months so far, and at time of going to press, the new Renold chains are still fitted.

Secondly, regular downtime due to the failure of the previous chains, was extended through the fitting of chain tensioners and their ongoing adjustments over time. With a time sensitive maintenance policy, the chocolate manufacturer looked for a solution to speed up the tensioning of the replacement chain and Roll-Ring® provided that simple solution.

The new Renold chains had to be adjusted to be near their ideal centres when fitted, and when the maximum compression was reached the Roll-Ring® was fitted by hand within seconds.

No further adjustments have had to be carried out due to the flexibility of the Roll-Ring® design and all future chain extension will be automatically taken up during the chains' life. With a large reduction in equipment downtime for tensioning adjustment, the chocolate manufacturer now enjoys significant time savings, cost savings and peace of mind.

- Saving of maintenance time for tension adjustments
- Simple installation
- Effective dampening
- Unique solution

The New Principle

The principle of the Roll-Ring® chain tensioner is based on two simple phenomena:

- The elastic ring engages with the chain drive strands and rolls between them in a pre-stressed condition taking up the shape of an ellipse
- The constantly opposing movements of the load and slack strands cancel each other out, thereby holding the Roll-Ring® in position



Roll-Ring® chain tensioners in one of our test rigs



Roll-Ring® chain tensioners are re-cyclable



Installation and maintenance

Roll-Ring® chain tensioners are maintenance free and can be fitted to a wide variety of chain drives with no installation down time.

The requirement is that:

- There is a working space with a gap between the chain strands which is smaller than the reference diameter of the chain tensioner.
- There is a sufficient gap between the chain drive sprockets.

We recommend that the chain tensioner is positioned between two chain strands such that there is at least one chain pitch between the Roll-Ring® and the smallest sprocket. The Roll-Ring® can also be positioned just as effectively outside this recommended area, as long as it is sufficiently prestressed. In this case, practical trial and error are recommended.

Roll-Ring® chain tensioners can be used in line within the same chain strand, or parallel with each other in multi-strand chain drives.

Please note that triplex chain drives only require two Roll-Rings® positioned on the outer strands.

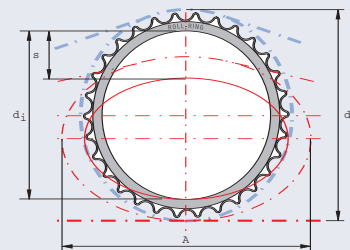

Key

- A = Deflected PCD
- do = PCD
- S = Max deflection
- di = Inside Diameter

Renold Roll-Ring® installation and final dimensions

Part number	do	di	s	A
10503001	76.5	65.0	20.0	104.0
10603001	91.1	73.0	25.0	122.0
10603601	109.0	89.5	25.0	143.0
10802601	102.1	84.5	24.0	135.8
10803001	121.5	98.0	28.0	161.6
10803401	137.5	115.4	30.0	165.0
11002601	128.4	105.0	28.0	153.0
11003001	148.0	124.6	33.0	177.0
11003401	170.0	141.0	38.0	217.0
11202601	155.0	127.6	35.0	209.5
11203001	182.2	145.0	40.0	241.7
11203401	207.5	169.5	45.0	265.0
11602601	207.0	167.0	45.0	269.0
11603001	245.8	202.0	50.0	306.0
12003001	303.7	244.0	60.0	390.0

Value A includes a safety distance to the sprockets.

Chain Tensioners Standard Product Range

Part No. number	No. of teeth	ISO reference	Renold Chain reference	Maximum static expansive force * *	Maximum chain speed (M/S)	Minimum ambient temperature ~ (C)	Maximum ambient temperature ~ (C)	Resistant to ultra violet light
10503001	30	05B	110500	2.9	5.0	-20	70	Normal
10603001	30	06B	110038	15.2	5.2	-20	70	Normal
10603601	36	06B	110038	28.5	5.2	-20	70	Normal
10802601	26	08B	110046	15.7	7.5	-20	70	Normal
10803001	30	08B	110046	22.0	8.6	-20	70	Normal
10803401	34	08B	110046	22.0	8.8	-20	70	Normal
10843001	30	081 \ 083 *	111044 \ 6	16.8	7.5	-20	70	Normal
11002601	26	10B	110056	28.2	4.2	-20	70	Normal
11003001	30	10B	110056	23.0	8.8	-20	70	Normal
11003401	34	10B	110056	45.1	8.8	-20	70	Normal
11202601	26	12B	110066	39.2	5.4	-20	70	Normal
11203001	30	12B	110066	65.0	6.2	-20	70	Normal
11203401	34	12B	110066	70.5	6.4	-20	70	Normal
11602601	26	16B	110088	95.7	5.7	-20	70	Normal
11603001	30	16B	110088	108.5	6.2	-20	70	Normal
12003001	30	20B	110106	194.0	7.0	-20	60	Normal
<hr/>								
80603001	30	35	129033	5.7	5.2	-20	70	Normal
10802601	26	40	119043	15.2	7.5	-20	70	Normal
10803001	30	40	119043	22.0	8.6	-20	70	Normal
10843001	30	41	119040	16.8	7.5	-20	70	Normal
11002601	26	50	119053	28.2	4.2	-20	70	Normal
11003001	30	50	119053	23.0	8.8	-20	70	Normal
11003401	34	50	119053	45.1	8.8	-20	70	Normal
11202601	26	60	119063	39.2	5.4	-20	70	Normal
11203001	30	60	119063	65.0	6.2	-20	70	Normal
11602601	26	80	119083	95.7	5.7	-20	70	Normal
81603001	30	80	119083	103.0	6.6	-20	70	Normal
12003001	30	100	119103	194.0	7.0	-20	60	Normal
<hr/>								
20802601	26	08B	110046	13.5	7.1	-20	70	High #
20803001	30	08B	110046	20.4	7.4	-20	70	High #
20843001	30	081 \ 083 *	111044 \ 6	15.4	6.8	-20	70	High #
21003001	30	10B	110056	20.0	7.8	-20	70	High #
21202601	26	12B	110066	37.0	5.0	-20	70	High #
21203001	30	12B	110066	52.0	5.6	-20	70	High #
21603001	30	16B	110088	100.6	5.8	-20	70	High #
22003001	30	20B	110106	165.8	6.3	-15	60	High #

- # Ultra Violet resistant Roll-Rings® for use in equipment where the Roll-Ring® is exposed to Ultra Violet Light ie. agricultural machinery, community service equipment, building machines etc.
- ~ For special operational temperatures lower or higher than those listed please consult Renold.
- * To fit all roller chain widths from 1/8 to 5/16".
- * * At 20°C maximum adjustment, without dynamic expansive force proportional to chain speed.
- NB** Ultra Violet resistant Roll-Rings® have different mechanical properties to the standard Roll-Ring® which could result in a lower service life.

The above information is based on current knowledge and experience, we reserve the right to make modifications as part of our technical product improvement programme.

Industries

Typical applications:

- Agricultural machinery
- Baggage handling
- Cardboard manufacture
- Ground compression machines
- Kiln conveyors
- Manufacture of drive systems
- Manufacture of pressing plants
- Paper cutting machines

- Printing machines
- Road building machines
- Robotics
- Roller drive systems
- Tile manufacture
- Transport systems
- Wood chip conveying
- Chocolate manufacture

Registered trademark
641 683 from Ebert



The range of ROLL-RING® products continues to increase. Please consult Renold to discuss your particular requirements.

Renold manufacture a comprehensive range of stock sprockets for British Standard chain up to two inch pitch.

Other sizes of sprocket, including those to American Standard dimensions, are available on request.

Special sprockets are also manufactured on request, in special materials or formats, normally to suit a specific application in harsh or difficult drive situations, examples being:

- Sprockets incorporating shafts.
- Welded or detachable hubs.
- Shear pin devices fitted.
- Necklace sprockets made up of chain plates and individual tooth sections for turning large drums or tables.
- Combination sprockets (two or more sprockets combined having different pitch sizes and numbers of teeth).
- Sprockets in two or more sections, i.e. split sprockets or segmental sprockets.

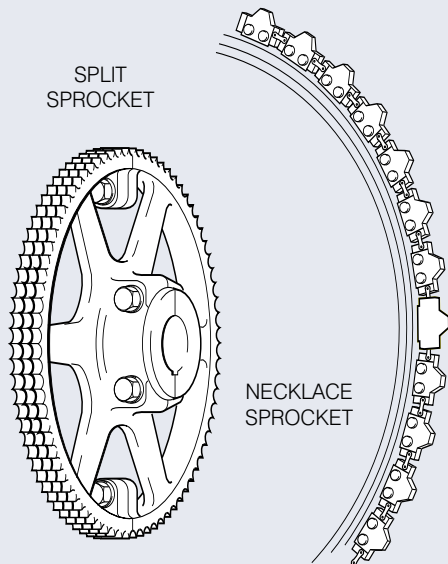

Selection of Sprocket Materials

Choice of material and heat treatment will depend upon shape, diameter and mass of the sprocket. The table below can be used as a simple guide on the correct selection of sprocket material.

SPROCKET	SMOOTH RUNNING	MODERATE SHOCKS	HEAVY SHOCKS
UP TO 29T	EN8 or EN9	EN8 or EN9 Hardened and Tempered or Case Hardened Mild Steel	EN8 or EN9 Hardened and Tempered or Case Hardened Mild Steel
30T AND OVER	Cast Iron	Mild Steel or Meehanite	EN8 or EN9 Hardened and Tempered or Case Hardened Mild Steel

Sprocket and Chain Compatibility

Most drives have an even number of pitches in the chain and by using a driver sprocket with an odd number of teeth, uniform wear distribution over both chain and sprocket teeth is ensured. Even numbers of teeth for both the driver and driven sprockets can be used, but wear distribution on both the sprocket teeth and chain is poor.

Number of Teeth

The maximum number of teeth in any driven sprocket should not exceed 114. This limitation is due to the fact that for a given elongation of chain due to wear, the working pitch diameter of the chain on the sprocket increases in relation to the nominal pitch diameter, i.e. the chain assumes a higher position on the sprocket tooth. The allowable safe chain wear is considered to be in the order of 2% elongation over nominal length.

A simple formula for determining how much chain elongation a sprocket can accommodate is $\frac{200}{N}$

expressed as a percentage where N is the number of teeth on the largest sprocket in the drive system.

It is good practice to have the sum of teeth not less than 50 where both the driver and driven sprockets are operated by the same chain, e.g. on a 1:1 ratio drive. both sprockets should have 25 teeth each.

Centre Distance

For optimum wear life, centre distance between two sprockets should normally be within the range 30 to 50 times the chain pitch. On drive proposals with centre distances below 30 pitches or greater than 2m, we would recommend that the drive details are discussed with our technical staff.

The minimum centre distance is sometimes governed by the amount of chain lap on the driver sprocket, our normal recommendation in this circumstance being not less than six teeth in engagement with the chain.

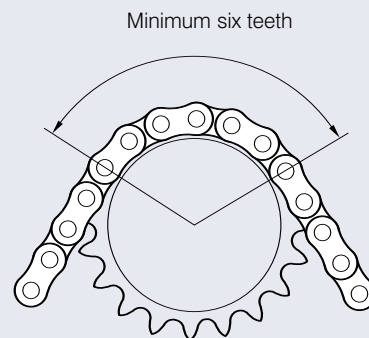

The centre distance is also governed by the desirability of using a chain with an even number of pitches to avoid the use of a cranked link, a practice that is not recommended except in special circumstances.

For a drive in the horizontal plane, the shortest centre distance possible should be used consistent with recommended chain lap (minimum six teeth) on the driver sprocket.

Transmission Sprockets ISO606

9.525mm (0.375") Pitch

Tooth Width SIMPLEX B1 - 5.3 mm
 Tooth Width b1 - 5.2 mm
 Tooth Width DUPLEX B2 - 15.4 mm
 Tooth Width TRIPLEX B3 - 25.6 mm

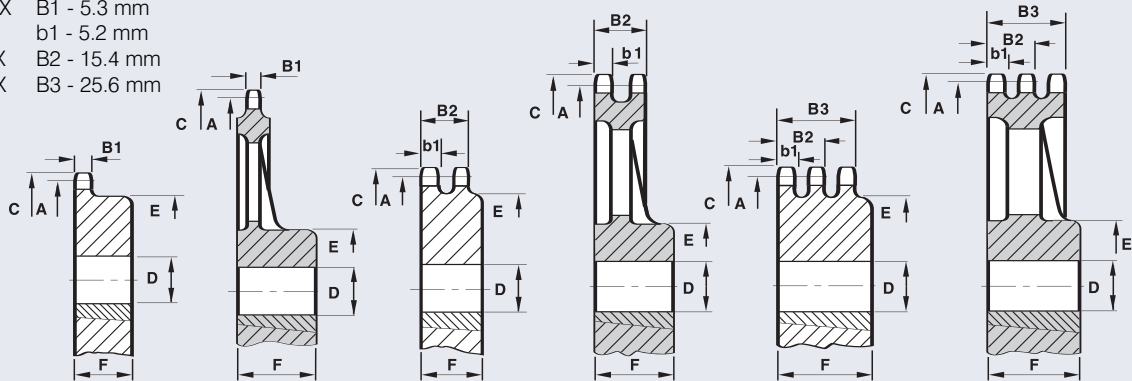

Key



Plain Bore - Steel

No of Teeth	PCD	Top Dia A	SIMPLEX					DUPLEX					TRIPLEX				
			Part No C	Bore Min	D Max	Boss Dia	Dist' Thro' E	Part No F	Bore Min	D Max	Boss Dia	Dist' Thro' E	Part No F	Bore Min	D Max	Boss Dia E	Dist' Thro' F
11	33.80	37.5	06B1/11T	8	14	22	25	06B2/11T	10	14	22	30	06B3/11T	12	14	22	35
12	36.80	40.5	06B1/12T	8	16	25	25	06B2/12T	10	16	25	30	06B3/12T	12	16	25	35
13	39.80	43.5	06B1/13T	10	16	28	25	06B2/13T	10	16	28	30	06B3/13T	12	16	28	35
14	42.80	46.5	06B1/14T	10	20	31	25	06B2/14T	10	20	31	30	06B3/14T	12	22	31	35
15	45.81	49.5	06B1/15T	10	22	34	25	06B2/15T	10	22	34	30	06B3/15T	12	22	34	35
16	48.82	52.5	06B1/16T	10	22	37	28	-	-	-	-	-	-	-	-	-	-
17	51.83	55.5	06B1/17T	10	25	40	28	06B2/17T	12	25	40	30	06B3/17T	12	25	40	35
18	54.85	58.6	06B1/18T	10	25	43	28	-	-	-	-	-	-	-	-	-	-
19	57.87	61.6	06B1/19T	10	28	45	28	06B2/19T	12	28	46	30	06B3/19T	12	28	46	35
20	60.89	64.6	06B1/20T	10	30	46	28	06B2/20T	12	30	49	30	06B3/20T	12	30	49	35
21	63.91	67.6	06B1/21T	12	32	48	28	06B2/21T	16	35	52	30	06B3/21T	16	35	52	40
22	66.93	70.6	06B1/22T	12	32	50	28	-	-	-	-	-	-	-	-	-	-
23	69.95	73.7	06B1/23T	12	38	52	28	06B2/23T	16	42	58	30	06B3/23T	16	42	58	40
24	72.97	76.7	06B1/24T	12	38	54	28	-	-	-	-	-	-	-	-	-	-
25	76.00	79.7	06B1/25T	12	38	57	28	06B2/25T	16	42	64	30	06B3/25T	16	42	64	40
26	79.02	82.7	06B1/26T	12	38	60	28	-	-	-	-	-	-	-	-	-	-
27	82.04	85.7	06B1/27T	12	38	60	28	06B2/27T	16	42	70	30	06B3/27T	16	42	70	40
30	91.12	94.8	06B1/30T	12	35	60	28	06B2/30T	16	40	79	30	06B3/30T	16	45	79	40
38	115.34	119.0	06B1/38T	16	42	70	30	06B2/38T	16	50	90	30	06B3/38T	16	55	90	40

Plain Bore - Heavy Duty Cast Iron

57	172.94	177.5	06B1/57T	19	45	80	25	06B2/57T	24	50	90	25	06B3/57T	28	55	95	38
76	230.49	235.1	06B1/76T	19	45	80	25	06B2/76T	24	50	90	25	06B3/76T	28	65	110	45
95	288.08	292.7	06B1/95T	24	50	90	25	06B2/95T	28	55	95	38	06B3/95T	28	65	110	45
114	345.68	350.3	06B1/114T	24	50	90	38	06B2/114T	28	55	95	38	06B3/114T	28	65	110	52
150	454.81	461.2	06B1/150T	24	50	90	45	06B2/150T	35	65	110	52	-	-	-	-	-

Taper Bore - Steel

No of Teeth	PCD	Top Dia A	Taper Bush				Taper Bush				Taper Bush			
			Part No C	Bore Min	D Max	Dist' Thro' E	Part No F	Bore Min	D Max	Dist' Thro' E	Part No F	Bore Min	D Max	Dist' Thro' F
17	51.83	55.5	T06B1/17T	TB1008	45	22	T06B2/17T	TB1008	41	22	T06B3/17T	TB1008	-	25.6
19	57.87	61.6	T06B1/19T	TB1008	45	22	T06B2/19T	TB1008	46	22	T06B3/19T	TB1008	-	25.6
21	63.91	67.6	T06B1/21T	TB1008	46	22	T06B2/21T	TB1008	49	22	T06B3/21T	TB1008	-	25.6
23	69.95	73.7	T06B1/23T	TB1210	63	25	T06B2/23T	TB1210	59	25	T06B3/23T	TB1210	-	25.6
25	76.00	79.7	T06B1/25T	TB1210	63	25	T06B2/25T	TB1210	64	25	T06B3/25T	TB1210	-	25.6
38	115.34	119.0	T06B1/38T	TB1210	70	25	T06B2/38T	TB1610	80	25	T06B3/38T	TB1615	90	38

Taper Bore - Heavy Duty Cast Iron

57	172.94	177.5	T06B1/57T	TB1210	80	25	T06B2/57T	TB1610	90	25	T06B3/57T	TB1615	95	38
76	230.49	235.1	T06B1/76T	TB1210	80	25	T06B2/76T	TB1610	90	25	T06B3/76T	TB2017	110	45
95	288.08	292.7	T06B1/95T	TB1210	90	25	T06B2/95T	TB1615	95	38	-	-	-	-
114	345.68	350.3	T06B1/114T	TB1615	90	38	T06B2/114T	TB1615	95	38	-	-	-	-

REBORE, KEYWAY AND SETSCREW MODIFICATION SERVICE AVAILABLE - SEE PAGE 73

Tooth Width SIMPLEX B1 - 7.2 mm
 Tooth Width b1 - 7.1 mm
 Tooth Width DUPLEX B2 - 21.0 mm
 Tooth Width TRIPLEX B3 - 34.9 mm

Key

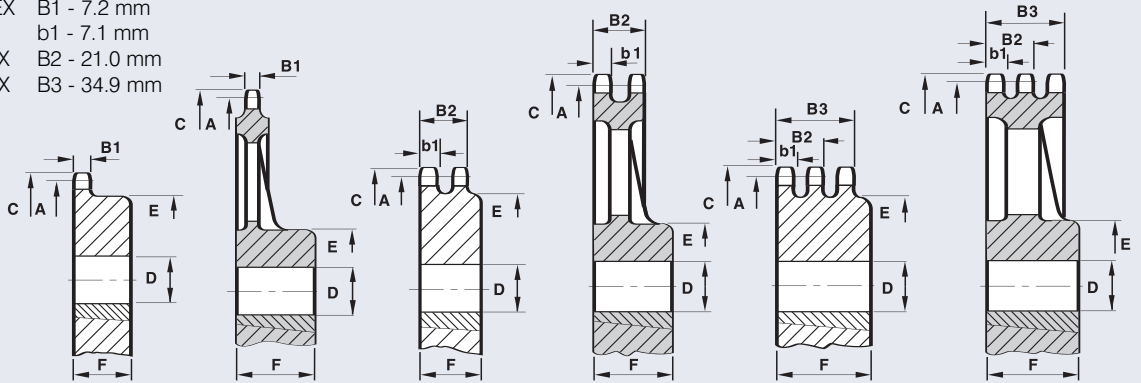

Plain Bore - Steel

No of Teeth	PCD	Top Dia A	SIMPLEX				DUPLEX				TRIPLEX						
			Part No C	Bore Min	D Max	Boss Dia E	Dist' Thro' F	Part No	Bore Min	D Max	Boss Dia E	Dist' Thro' F	Part No	Bore Min	D Max	Boss Dia E	Dist' Thro' F
11	45.07	49.9	08B1/11T	10	19	29	25	08B2/11T	12	20	32	35	08B3/11T	16	20	32	50
12	49.07	53.9	08B1/12T	10	22	33	28	08B2/12T	12	22	35	35	08B3/12T	16	22	35	50
13	53.07	57.9	08B1/13T	10	25	37	28	08B2/13T	12	25	38	35	08B3/13T	16	25	38	50
14	57.07	61.9	08B1/14T	10	25	41	28	08B2/14T	12	28	42	35	08B3/14T	16	28	42	50
15	61.09	65.9	08B1/15T	10	32	45	28	08B2/15T	12	32	46	35	08B3/15T	16	32	46	50
16	65.10	69.9	08B1/16T	12	33	50	28	-	-	-	-	-	-	-	-	-	-
17	69.11	74.0	08B1/17T	12	35	52	28	08B2/17T	16	38	54	38	08B3/17T	16	38	54	50
18	73.14	78.0	08B1/18T	12	35	56	28	-	-	-	-	-	-	-	-	-	-
19	77.16	82.0	08B1/19T	12	40	60	28	08B2/19T	16	42	62	38	08B3/19T	16	42	62	50
20	81.18	86.0	08B1/20T	12	42	64	28	08B2/20T	16	42	66	38	08B3/20T	16	42	66	50
21	85.22	90.1	08B1/21T	14	45	68	28	08B2/21T	16	45	70	40	08B3/21T	16	45	70	55
22	89.24	94.1	08B1/22T	14	45	70	28	-	-	-	-	-	-	-	-	-	-
23	93.27	98.1	08B1/23T	14	45	70	28	08B2/23T	16	45	70	40	08B3/23T	16	45	70	55
24	97.29	102.1	08B1/24T	14	45	70	28	-	-	-	-	-	-	-	-	-	-
25	101.33	106.2	08B1/25T	14	45	70	28	08B2/25T	16	48	80	40	08B3/25T	16	48	80	55
26	105.36	110.2	08B1/26T	16	45	70	30	-	-	-	-	-	-	-	-	-	-
27	109.40	114.2	08B1/27T	16	45	70	30	08B2/27T	16	58	85	40	08B3/27T	20	58	85	55
30	121.50	126.3	08B1/30T	16	48	80	30	08B2/30T	16	60	100	40	08B3/30T	20	60	100	55
38	153.80	158.6	08B1/38T	16	60	90	35	08B2/38T	20	60	100	40	08B3/38T	25	72	120	55

Plain Bore - Heavy Duty Cast Iron

57	230.54	237.1	08B1/57T	19	60	110	32	08B2/57T	28	65	110	32	08B3/57T	28	65	110	45
76	307.33	313.9	08B1/76T	19	60	110	32	08B2/76T	38	65	110	45	08B3/76T	38	75	130	64
95	384.11	390.7	08B1/95T	24	50	90	45	08B2/95T	38	65	110	52	08B3/95T	38	75	130	64
114	460.90	467.4	08B1/114T	34	50	90	45	08B2/114T	38	65	110	58	08B3/114T	38	75	130	72

Taper Bore - Steel

No of Teeth	PCD	Top Dia A	Taper Bush				Taper Bush				Taper Bush			
			Part No C	Taper Bush	Bore Min	D Max	Part No	Taper Bush	Bore Min	D Max	Part No	Taper Bush	Bore Min	D Max
15	61.08	65.9	T08B1/15T	TB1008	45	22	T08B2/15T	TB1008	48	22	-	-	-	-
17	69.12	74.0	T08B1/17T	TB1210	60	25	T08B2/17T	TB1210	56	25	-	-	-	-
19	77.16	82.0	T08B1/19T	TB1210	63	25	T08B2/19T	TB1210	64	25	T08B3/19T	TB1215	62	38
21	85.21	90.1	T08B1/21T	TB1610	71	25	T08B2/21T	TB1610	71	25	T08B3/21T	TB1615	70	38
23	93.27	98.1	T08B1/23T	TB1610	76	25	T08B2/23T	TB1610	79	25	T08B3/23T	TB1615	70	38
25	101.33	106.2	T08B1/25T	TB1610	76	25	T08B2/25T	TB2012	87	32	T08B3/25T	TB2017	-	34.9

Taper Bore - Heavy Duty Cast Iron

38	153.79	158.6	T08B1/38T	TB2012	90	32	T08B2/38T	TB2012	100	32	T08B3/38T	TB2017	-	34.9
57	230.54	237.1	T08B1/57T	TB2012	110	32	T08B2/57T	TB2012	110	32	T08B3/57T	TB2017	110	45
76	307.33	313.9	T08B1/76T	TB2012	110	32	T08B2/76T	TB2012	110	32	T08B3/76T	TB2525	130	64
95	384.11	390.7	T08B1/95T	TB2012	110	32	T08B2/95T	TB2012	110	32	-	-	-	-
114	460.90	467.4	T08B1/114T	TB2017	110	32	T08B2/114T	TB2517	125	45	-	-	-	-

REBORE, KEYWAY AND SETSCREW MODIFICATION SERVICE AVAILABLE - SEE PAGE 73

Transmission Sprockets ISO606

15.875mm (0.625") Pitch

Tooth Width SIMPLEX B1 - 9.2 mm
 Tooth Width b1 - 9.0 mm
 Tooth Width DUPLEX B2 - 25.6 mm
 Tooth Width TRIPLEX B3 - 42.2 mm

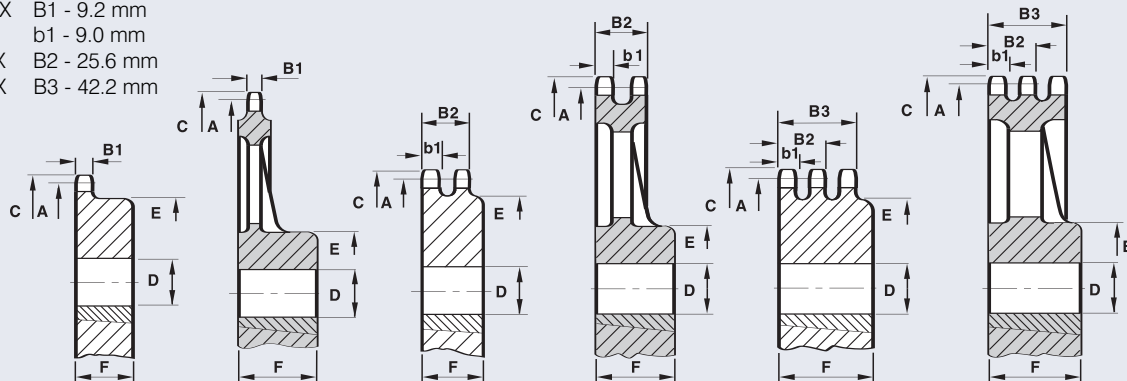

Plain Bore - Steel

No of Teeth	PCD	Top Dia A	Part No C	SIMPLEX		Boss Dia E	Dist' Thro' F	Part No	DUPLEX		Boss Dia E	Dist' Thro' F	Part No	TRIPLEX		Boss Dia E	Dist' Thro' F
				Bore Min	D Max				Bore Min	D Max				Bore Min	D Max		
11	56.34	63.2	10B1/11T	12	25	37	30	10B2/11T	16	25	39	40	-	-	-	-	-
12	61.34	68.2	10B1/12T	12	28	42	30	10B2/12T	16	28	44	40	-	-	-	-	-
13	66.32	73.2	10B1/13T	12	30	47	30	10B2/13T	16	30	49	40	-	-	-	-	-
14	71.34	78.2	10B1/14T	12	32	52	30	10B2/14T	16	30	54	40	-	-	-	-	-
15	76.36	83.2	10B1/15T	12	32	57	30	10B2/15T	16	36	59	40	-	-	-	-	-
16	81.37	88.3	10B1/16T	12	36	60	30	-	-	-	-	-	-	-	-	-	-
17	86.39	93.3	10B1/17T	12	36	60	30	10B2/17T	16	42	69	45	-	-	-	-	-
18	91.42	98.3	10B1/18T	14	42	70	30	-	-	-	-	-	-	-	-	-	-
19	96.45	103.3	10B1/19T	14	42	70	30	10B2/19T	16	48	79	45	-	-	-	-	-
20	101.49	108.4	10B1/20T	14	45	75	30	10B2/20T	16	50	84	45	-	-	-	-	-
21	106.52	113.4	10B1/21T	16	45	75	30	10B2/21T	16	50	85	45	-	-	-	-	-
22	111.55	118.4	10B1/22T	16	48	80	30	-	-	-	-	-	-	-	-	-	-
23	116.58	123.5	10B1/23T	16	48	80	30	10B2/23T	16	60	95	45	-	-	-	-	-
24	121.62	128.5	10B1/24T	16	48	80	30	-	-	-	-	-	-	-	-	-	-
25	126.66	133.6	10B1/25T	16	48	80	30	10B2/25T	16	65	105	45	-	-	-	-	-
26	131.70	138.6	10B1/26T	20	50	85	35	-	-	-	-	-	-	-	-	-	-
27	136.75	143.6	10B1/27T	20	50	85	35	-	-	-	-	-	-	-	-	-	-
30	151.87	158.8	10B1/30T	20	55	90	35	10B2/30T	20	72	120	45	-	-	-	-	-
38	192.24	199.1	10B1/38T	20	60	100	35	-	-	-	-	-	-	-	-	-	-

Plain Bore - Heavy Duty Cast Iron

57	288.18	296.6	10B1/57T	24	50	90	45	-	-	-	-	-	-	-	-	-	-
76	384.15	392.5	10B1/76T	28	50	90	52	-	-	-	-	-	-	-	-	-	-
95	480.14	488.5	10B1/95T	28	50	90	58	-	-	-	-	-	-	-	-	-	-
114	576.13	584.5	10B1/114T	38	75	130	58	-	-	-	-	-	-	-	-	-	-

Taper Bore - Steel

No of Teeth	PCD	Top Dia A	Part No C	Taper Bush		Boss Dia E	Dist' Thro' F	Part No	Taper Bush		Boss Dia E	Dist' Thro' F	Part No	Taper Bush		Boss Dia E	Dist' Thro' F
				Bore Min	D Max				Bore Min	D Max				Bore Min	D Max		
15	76.36	83.2	T10B1/15T	TB1210	60	25	-	-	-	-	-	-	-	-	-	-	-
17	86.40	93.3	T10B1/17T	TB1610	71	25	-	-	-	-	-	-	-	-	-	-	-
19	96.45	103.3	T10B1/19T	TB1610	75	25	-	-	-	-	-	-	-	-	-	-	-
21	106.51	113.4	T10B1/21T	TB1610	76	25	-	-	-	-	-	-	-	-	-	-	-
23	116.59	123.5	T10B1/23T	TB1610	76	25	-	-	-	-	-	-	-	-	-	-	-
25	126.66	133.6	T10B1/25T	TB2012	90	32	-	-	-	-	-	-	-	-	-	-	-

Taper Bore - Heavy Duty Cast Iron

38	151.87	158.8	T10B1/38T	TB2012	90	32	-	-	-	-	-	-	-	-	-	-	-
57	288.18	296.6	T10B1/57T	TB2012	110	32	-	-	-	-	-	-	-	-	-	-	-
76	384.15	392.5	T10B1/76T	TB2012	115	32	-	-	-	-	-	-	-	-	-	-	-
95	480.14	488.5	T10B1/95T	TB2012	115	45	-	-	-	-	-	-	-	-	-	-	-

REBORE, KEYWAY AND SETSCREW MODIFICATION SERVICE AVAILABLE - SEE PAGE 73

Tooth Width SIMPLEX B1 - 11.1 mm
 Tooth Width b1 - 10.9 mm
 Tooth Width DUPLEX B2 - 30.4 mm
 Tooth Width TRIPLEX B3 - 49.8 mm

* Welded Hub

Key

 Steel

 Cast Iron

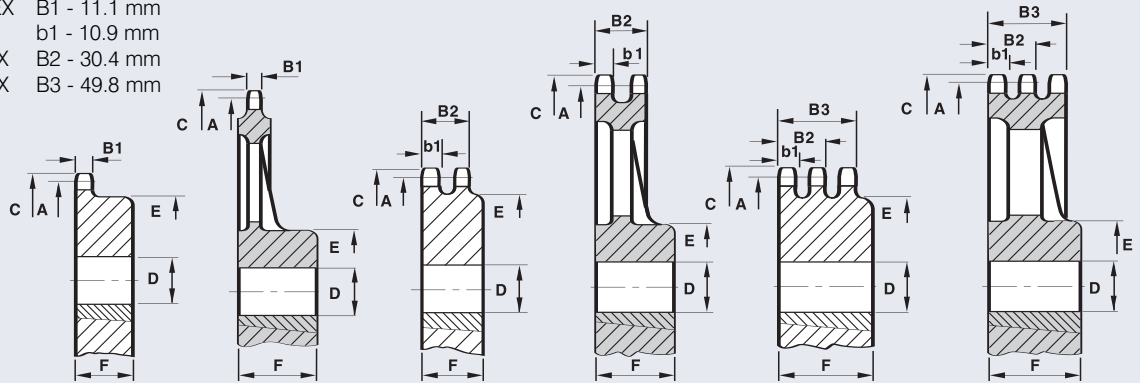

Plain Bore - Steel

No of Teeth	PCD	Top Dia A	SIMPLEX				DUPLEX				TRIPLEX						
			Part No C	Bore Min	D Max	Boss Dia E	Dist' Thro' F	Part No	Bore Min	D Max	Boss Dia E	Dist' Thro' F	Part No	Bore Min	D Max	Boss Dia E	Dist' Thro' F
11	67.62	75.8	12B1/11T	16	30	46	35	12B2/11T	16	30	47	50	12B3/11T	20	30	47	70
12	73.60	81.8	12B1/12T	16	32	52	35	12B2/12T	16	32	53	50	12B3/12T	20	32	53	70
13	79.59	87.8	12B1/13T	16	38	58	35	12B2/13T	16	38	59	50	12B3/13T	20	38	59	70
14	85.61	93.8	12B1/14T	16	42	64	35	12B2/14T	20	42	65	50	12B3/14T	20	42	65	70
15	91.63	99.8	12B1/15T	16	48	70	35	12B2/15T	20	48	71	50	12B3/15T	20	48	71	70
16	97.65	105.8	12B1/16T	16	50	75	35	-	-	-	-	-	-	-	-	-	-
17	103.67	111.9	12B1/17T	16	53	80	35	12B2/17T	20	50	83	50	12B3/17T	20	50	83	70
18	109.71	117.9	12B1/18T	16	53	80	35	-	-	-	-	-	-	-	-	-	-
19	115.74	123.9	12B1/19T	16	53	80	35	12B2/19T	20	55	95	50	12B3/19T	20	55	95	70
20	121.78	130.0	12B1/20T	16	53	80	35	12B2/20T	20	60	100	50	12B3/20T	20	60	100	70
21	127.82	136.1	12B1/21T	20	55	90	40	12B2/21T	20	60	100	50	12B3/21T	25	60	100	70
22	133.86	142.1	12B1/22T	20	55	90	40	-	-	-	-	-	-	-	-	-	-
23	139.90	148.1	12B1/23T	20	55	90	40	12B2/23T	20	66	110	50	12B3/23T	25	66	110	70
24	145.94	154.1	12B1/24T	20	55	90	40	-	-	-	-	-	-	-	-	-	-
25	152.00	160.2	12B1/25T	20	55	90	40	12B2/25T	20	72	120	50	12B3/25T	25	72	120	70
26	158.04	166.2	12B1/26T	20	55	95	40	-	-	-	-	-	-	-	-	-	-
27	164.09	172.3	12B1/27T	20	55	95	40	12B2/27T	20	72	120	50	12B3/27T	25	72	120	70
30	182.25	190.4	12B1/30T	20	55	95	40	12B2/30T	20	72	120	50	12B3/30T	25	72	120	70
38	230.69	238.9	12B1/38T	25	60	100	40	12B2/38T*	25	72	120	50	12B3/38T*	25	78	130	70

Plain Bore - Heavy Duty Cast Iron

57	345.81	355.9	12B1/57T	28	55	110	52	12B2/57T	38	65	115	64	12B3/57T	48	90	160	76
76	460.98	471.1	12B1/76T	35	55	110	58	12B2/76T	48	90	155	76	12B3/76T	55	90	165	76
95	576.17	586.2	12B1/95T	38	65	110	64	12B2/95T	55	90	155	76	12B3/95T	38	100	172	76
114	691.36	701.4	12B1/114T	38	75	130	64	12B2/114T	55	100	170	88	12B3/114T	48	100	178	76

Taper Bore - Steel

No of Teeth	PCD	Top Dia A	Taper Bush				Taper Bush				Taper Bush					
			Part No C	Bore Min	D Max	Boss Dia E	Dist' Thro' F	Part No	Bore Min	D Max	Boss Dia E	Dist' Thro' F	Part No	Bore Min	D Max	Boss Dia E
15	91.63	99.8	12B1/15T	TB1610	71	25	12B2/15T	TB1615	72	38	12B3/15T	TB1615	-	-	-	49.8
17	103.67	111.9	12B1/17T	TB1610	76	25	12B2/17T	TB1615	80	38	12B3/17T	TB2012	-	-	-	49.8
19	115.74	123.9	12B1/19T	TB2012	90	32	12B2/19T	TB2012	90	32	12B3/19T	TB2012	-	-	-	49.8
21	127.82	136.0	12B1/21T	TB2517	102	44	12B2/21T	TB2517	107	44	12B3/21T	TB2517	-	-	-	49.8
23	139.90	148.1	12B1/23T	TB2517	108	44	12B2/23T	TB2517	108	44	12B3/23T	TB2517	-	-	-	49.8
25	152.00	160.2	12B1/25T	TB2517	108	44	12B2/25T	TB2517	108	44	12B3/25T	TB2517	-	-	-	49.8

Taper Bore - Heavy Duty Cast Iron

38	230.69	238.9	T12B1/38T	TB2517	108	44	T12B2/38T	TB3020	140	51	T12B3/38T	TB3020	140	51
57	345.81	355.9	T12B1/57T	TB2517	125	45	T12B2/57T	TB3020	155	51	T12B3/57T	TB3020	160	51
76	460.98	471.1	T12B1/76T	TB2517	125	45	T12B2/76T	TB3020	155	51	T12B3/76T	TB3020	160	51
95	576.17	586.2	T12B1/95T	TB2517	130	45	T12B2/95T	TB3020	155	51	T12B3/95T	TB3020	172	76
114	691.36	701.4	T12B1/114T	TB2525	130	64	T12B2/114T	TB3030	170	76	T12B3/114T	TB3030	178	76

REBORE, KEYWAY AND SETSCREW MODIFICATION SERVICE AVAILABLE - SEE PAGE 73

Transmission Sprockets ISO606

25.4mm (1.000") Pitch

Tooth Width SIMPLEX B1 - 16.2 mm
 Tooth Width b1 - 15.8 mm
 Tooth Width DUPLEX B2 - 47.7 mm
 Tooth Width TRIPLEX B3 - 79.6 mm

* Welded Hub

Key

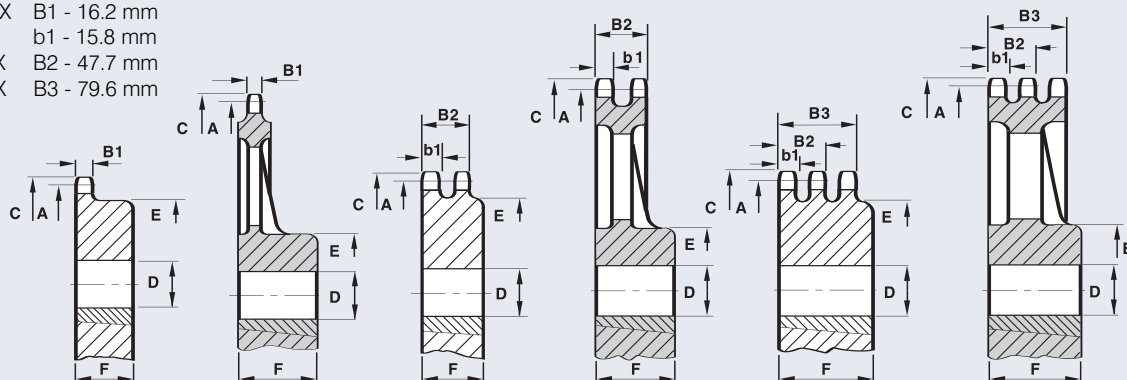

Plain Bore - Steel

No of Teeth	PCD	Top Dia A	SIMPLEX				DUPLEX				TRIPLEX						
			Part No C	Bore Min	D Max	Boss Dia E	Dist' Thro' F	Part No	Bore Min	D Max	Boss Dia E	Dist' Thro' F	Part No	Bore Min	D Max	Boss Dia E	Dist' Thro' F
11	90.14	101.7	16B1/11T	16	40	61	40	16B2/11T	20	44	64	70	16B3/11T	25	44	64	100
12	98.14	109.7	16B1/12T	16	45	69	40	16B2/12T	20	45	72	70	16B3/12T	25	45	72	100
13	106.12	117.7	16B1/13T	16	50	78	40	16B2/13T	20	50	80	70	16B3/13T	25	50	80	100
14	114.15	125.7	16B1/14T	16	55	84	40	16B2/14T	20	55	88	70	16B3/14T	25	55	88	100
15	122.17	133.7	16B1/15T	16	60	92	40	16B2/15T	20	60	96	70	16B3/15T	25	60	96	100
16	130.20	141.8	16B1/16T	20	60	100	45	-	-	-	-	-	-	-	-	-	-
17	138.22	149.8	16B1/17T	20	60	100	45	16B2/17T	25	72	112	70	16B3/17T	25	72	112	100
18	146.28	157.8	16B1/18T	20	60	100	45	-	-	-	-	-	-	-	-	-	-
19	154.33	165.9	16B1/19T	20	60	100	45	16B2/19T	25	82	128	70	16B3/19T	25	82	128	100
20	162.38	173.9	16B1/20T	20	60	100	45	16B2/20T	25	85	130	70	16B3/20T	25	85	130	100
21	170.43	182.0	16B1/21T	20	70	110	50	16B2/21T	25	85	130	70	16B3/21T*	25	85	130	100
22	178.48	190.1	16B1/22T	20	70	110	50	-	-	-	-	-	-	-	-	-	-
23	186.53	198.1	16B1/23T	20	70	110	50	16B2/23T*	25	85	130	70	16B3/23T*	25	85	130	100
24	194.59	206.2	16B1/24T	20	70	110	50	-	-	-	-	-	-	-	-	-	-
25	202.66	214.2	16B1/25T	20	70	110	50	16B2/25T*	25	85	130	70	16B3/25T*	25	85	130	100
26	210.72	222.3	16B1/26T	20	75	120	50	-	-	-	-	-	-	-	-	-	-
27	218.79	230.4	16B1/27T	20	75	120	50	16B2/27T*	25	85	130	70	16B3/27T*	30	85	130	100
30	243.00	254.6	16B1/30T	20	75	120	50	16B2/30T*	25	85	130	70	16B3/30T*	30	85	130	100
38	307.59	319.2	16B1/38T*	25	75	120	50	16B2/38T*	25	90	140	70	16B3/38T*	30	90	140	100

Plain Bore - Heavy Duty Cast Iron

57	461.08	474.9	16B1/57T	35	75	130	76	16B2/57T	38	100	178	89	16B3/57T	48	110	216	102
76	614.64	628.4	16B1/76T	35	75	135	76	16B2/76T	48	100	178	89	16B3/76T	55	110	216	102
95	768.22	782.0	16B1/95T	48	75	135	90	16B2/95T	48	110	216	102	16B3/95T	55	110	216	102
114	921.82	935.6	16B1/114T	38	100	172	98	16B2/114T	48	110	203	114	16B3/114T	55	125	222	127

Taper Bore - Steel

No of Teeth	PCD	Top Dia A	Taper Bush				Taper Bush				Taper Bush						
			Part No C	Bore Min	D Max	Boss Dia E	Dist' Thro' F	Part No	Bore Min	D Max	Boss Dia E	Dist' Thro' F	Part No	Bore Min	D Max	Boss Dia E	Dist' Thro' F
15	122.17	133.7	T16B1/15T	TB1615	76	38	T16B2/15T	TB2012	-	47.7	-	-	-	-	-	-	-
17	138.23	149.8	T16B1/17T	TB2012	90	32	T16B2/17T	TB2517	-	47.7	-	-	T16B3/17T	TB2525	-	79.6	-
19	154.32	165.9	T16B1/19T	TB2517	108	44	T16B2/19T	TB2517	-	47.7	-	-	T16B3/19T	TB3030	-	79.6	-
21	170.42	182.0	T16B1/21T	TB2517	110	44	T16B2/21T	TB3020	140	51	-	-	T16B3/21T	TB3030	-	79.6	-
23	186.54	198.1	T16B1/23T	TB2517	110	44	T16B2/23T	TB3020	140	51	-	-	T16B3/23T	TB3535	159	89	-
25	202.66	214.2	T16B1/25T	TB2517	110	44	T16B2/25T	TB3020	140	51	-	-	T16B3/25T	TB3535	175	89	-

Taper Bore - Heavy Duty Cast Iron

38	307.58	319.2	T16B1/38T	TB3020	155	51	T16B2/38T	TB3030	159	76	-	-	T16B3/38T	TB3535	178	89	-
57	461.08	474.9	T16B1/57T	TB3020	155	51	T16B2/57T	TB3535	178	89	-	-	T16B3/57T	TB4040	216	102	-
76	614.64	628.4	T16B1/76T	TB3020	160	51	T16B2/76T	TB3535	178	89	-	-	T16B3/76T	TB4040	216	102	-
95	768.22	782.0	T16B1/95T	TB3020	160	51	T16B2/95T	TB4040	216	102	-	-	T16B3/95T	TB4040	216	102	-

REBORE, KEYWAY AND SETSCREW MODIFICATION SERVICE AVAILABLE - SEE PAGE 73

Sprocket size

	1.25"p	1.5"pitch
Tooth Width SIMPLEX	B1 - 18.5	24.1mm
Tooth Width	b1 - 18.2	23.6mm
Tooth Width DUPLEX	B2 - 54.6	72.0mm
Tooth Width TRIPLEX	B3 - 91.0	120.3mm

* Welded Hub

Key

 Steel

 Cast Iron

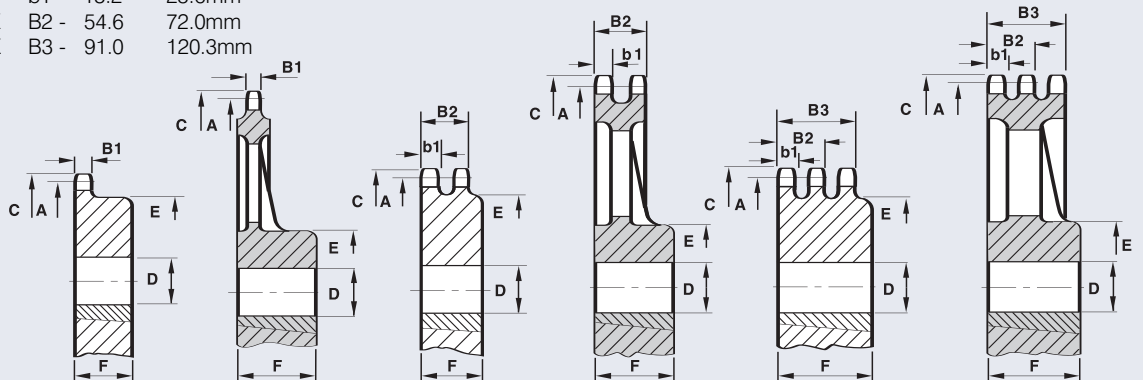

1.25" Plain Bore - Steel

No of Teeth	PCD	Top Dia A	SIMPLEX					DUPLEX					TRIPLEX				
			Part No C	Bore Min	D Max	Boss Dia E	Dist' Thro' F	Part No	Bore Min	D Max	Boss Dia E	Dist' Thro' F	Part No	Bore Min	D Max	Boss Dia E	Dist' Thro' F
17	172.80	190.75	20B1/17T	25	85	120	50	20B2/17T	30	85	120	80	20B3/17T	30	85	120	115
19	192.89	210.26	20B1/19T	25	85	120	50	20B2/19T	30	85	120	80	20B3/19T	30	85	120	115
21	213.03	232.41	20B1/21T	30	100	140	55	20B2/21T	30	100	140	80	20B3/21T	30	100	140	115
23	233.17	252.22	20B1/23T	30	100	140	55	20B2/23T	30	100	140	80	20B3/23T	30	100	140	115
25	253.31	272.03	20B1/25T	30	100	140	55	20B2/25T	30	100	140	80	20B3/25T	30	100	140	115

1.25" Plain Bore - Heavy Duty Cast Iron

38	384.48	402.08	20B1/38T	30	105	150	55	20B2/38T	30	105	150	80	20B3/38T	30	105	150	115
57	576.35	593.34	20B1/57T	48	95	170	81	20B2/57T	65	110	206	127	20B3/57T	70	125	222	147
76	768.30	784.86	20B1/76T	55	100	178	89	20B2/76T	70	125	224	140	20B3/76T	85	140	254	163

1.5" Plain Bore - Steel

17	207.34	225.55	24B1/17T	25	95	136	55	24B2/17T	30	95	136	100	24B3/17T	30	95	136	150
19	231.47	248.67	24B1/19T	25	95	136	55	24B2/19T	30	95	160	100	24B3/19T	30	114	160	150
21	255.63	276.61	24B1/21T	30	105	150	60	24B2/21T	30	114	160	100	24B3/21T	40	114	160	150
23	279.81	300.23	24B1/23T	30	105	150	60	24B2/23T	30	114	160	100	24B3/23T	40	114	160	150
25	303.99	324.10	24B1/25T	30	105	150	60	24B2/25T	30	114	160	100	24B3/25T	40	114	160	150

1.5" Plain Bore - Heavy Duty Cast Iron

38	461.37	479.81	24B1/38T	30	105	150	60	24B2/38T	40	114	160	100	24B3/38T	40	114	160	150
57	691.62	708.91	24B1/57T	60	110	196	122	24B2/57T	80	140	254	152	24B3/57T	90	150	267	175
76	921.97	938.78	24B1/76T	65	125	216	135	24B2/76T	85	150	267	168	24B3/76T	100	170	297	193

REBORE, KEYWAY AND SETSCREW MODIFICATION SERVICE AVAILABLE - SEE PAGE 73

Transmission Sprockets ISO606

44.45mm to 50.8mm (1.75" to 2.0") Pitch

Sprocket size

	1.75"p	2.0"pitch
Tooth Width SIMPLEX	B1 - 29.4	29.4mm
Tooth Width	b1 - 28.8	28.8mm
Tooth Width DUPLEX	B2 - 88.4	87.4mm
Tooth Width TRIPLEX	B3 - 148.0	146.0mm

* Welded Hub

Key

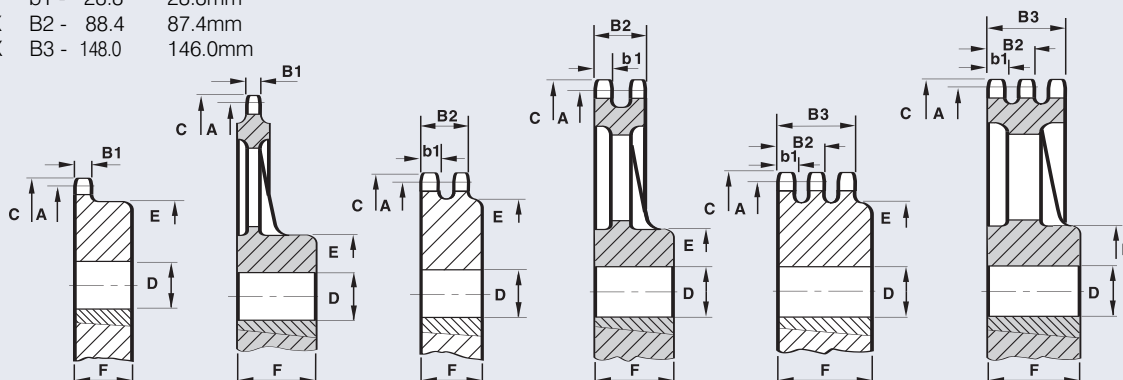

1.75" Plain Bore - Steel

No of Teeth	PCD	Top Dia A	Part No C	SIMPLEX				DUPLEX				TRIPLEX					
				Bore Min	Bore Max D	Boss Dia E	Dist' Thro' F	Part No	Bore Min	Bore Max D	Boss Dia E	Dist' Thro' F	Part No	Bore Min	Bore Max D	Boss Dia E	Dist' Thro' F
19	270.05	292.61	28B1/19T	30	114	160	75	28B2/19T	30	128	180	120	28B3/19T	30	128	180	180
21	298.25	324.36	28B1/21T	30	114	160	75	28B2/21T	30	128	180	120	28B3/21T	40	128	180	180
23	326.44	352.04	28B1/23T	30	114	160	75	28B2/23T	30	128	180	120	28B3/23T	40	128	180	180
25	354.66	379.98	28B1/25T	30	114	160	75	28B2/25T	30	128	180	120	28B3/25T	40	128	180	180

1.75" Plain Bore - Heavy Duty Cast Iron

38	538.28	538.28	28B1/38T	30	128	180	75	28B2/38T	40	142	200	120	28B3/38T	40	142	200	180
57	806.88	829.31	28B1/57T	70	125	224	147	28B2/57T	100	150	267	165	28B3/57T	105	188	264	165
76	1075.61	1097.53	28B1/76T	85	140	244	165	28B2/76T	100	150	267	165	28B3/76T	120	202	284	178

2.0" Plain Bore - Steel

19	308.64	337.82	32B1/19T	30	114	160	90	32B2/19T	40	142	200	120	32B3/19T	40	142	200	180
21	340.84	372.66	32B1/21T	40	128	180	90	32B2/21T	40	142	200	120	32B3/21T	40	142	200	180
23	373.08	404.37	32B1/23T	40	128	180	90	32B2/23T	40	142	200	120	32B3/23T	40	142	200	180
25	405.31	436.12	32B1/25T	40	128	180	90	32B2/25T	40	142	200	120	32B3/25T	40	142	200	180

2.0" Plain Bore - Heavy Duty Cast Iron

38	615.16	644.40	32B1/38T	40	142	200	90	32B2/38T	100	174	244	165	32B3/38T	105	188	264	165
57	922.17	950.47	32B1/57T	85	174	244	165	32B2/57T	105	188	264	165	32B3/57T	120	202	284	178
76	1229.28	1275.05	32B1/76T	100	190	267	165	32B2/76T	120	202	284	178	32B3/76T	130	232	325	191

REBORE, KEYWAY AND SETSCREW MODIFICATION SERVICE AVAILABLE - SEE PAGE 73

Renold Large Pitch Sprockets

Detailed in this catalogue are SIMPLE, DUPLEX and TRIPLEX sprockets for British Standard Transmission Chain up to 1.00" pitch. 1.25" to 2.00" pitch sprockets are available to Renold specifications from stock. For more details contact Renold Chain. Renold also manufacture sprockets of intermediate numbers of teeth to suit single or multi-strand chains.

Special Sprockets

In addition to this stock range, special design sprockets in normal or special materials can be manufactured to specific requirements.

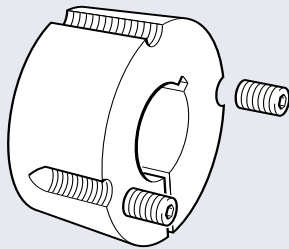

American (ANSI) Standard Sprockets

Sprockets to suit chain manufactured to ANSI specification B 29.1 are made to order.

Rebore, Keyway and Setscrew Modification Service

Catalogued stock sprockets are supplied either taper bored or pilot bored. This pilot bore allows a larger finished bore to standard H8 tolerances to be machined. A bore to H7 tolerance can also be supplied on request. Keyways to imperial or metric specifications and setscrews can also be machined. A rebore, keyway and setscrew modification service is available and further details can be obtained on request.

Taper Bushes

Taper bushes provide the quickest and simplest means of securing sprockets to a range of both imperial and metric shafts and are designed to give maximum grip.

The taper surface to both the bush and sprocket combine to provide a load bearing connection by the lock action of the hardened high tensile screws.

OUR RANGE OF TAPER BUSHES ARE FULLY INTERCHANGEABLE WITH MOST OTHER MAKES OF TAPER BUSH.

BUSH No	AVAILABLE BORE SIZES - METRIC mm															
TB1008	9	10	12	14	16	18	19	20	22	24	25					
TB1210	11	12	14	16	18	19	20	22	24	25	28	30	32			
TB1215	11	12	14	16	18	19	20	22	24	25	28	30	32			
TB1610	14	16	18	19	20	22	24	25	28	30	32	35	38	40	42	
TB1615	14	16	18	19	20	22	24	25	28	30	32	35	38	40	42	
TB2012	14	16	18	19	20	22	24	25	28	30	32	35	38	40	42	44
TB2017	18	19	20	22	24	25	28	30	32	35	38	40	42	45	48	50
TB2517	16	18	19	20	22	24	25	28	30	32	35	38	40	42	45	48
TB2525	19	20	22	24	25	28	30	32	35	38	40	42	45	48	50	55
TB3020	25	28	30	32	35	38	40	42	45	48	50	55	60	65	70	75
TB3030	35	38	40	42	45	48	50	55	60	65	70	75				
TB3535	35	38	40	42	45	48	50	55	60	65	70	75	80	85	90	
TB4040	40	42	45	48	50	55	60	65	70	75	80	85	90	95	100	

BUSH No	AVAILABLE BORE SIZES - IMPERIAL Inch															
TB1008	0.375	0.437	0.50	0.625	0.750	1.000										
TB1210	0.50	0.625	0.750	1.00	1.125	1.250										
TB1215	0.50	0.562	0.625	0.750	0.875	1.00	1.125	1.250								
TB1610	0.50	0.625	0.750	0.875	1.00	1.125	1.250	1.50	1.625							
TB1615	0.50	0.625	0.750	0.875	1.00	1.125	1.250	1.375	1.437	1.50	1.625					
TB2012	0.50	0.625	0.750	0.975	1.00	1.125	1.250	1.375	1.50	1.625	1.750	1.875	2.00			
TB2017	0.75	0.812	0.875	0.937	1.00	1.125	1.250	1.375	1.437	1.50	1.625	1.750	1.875	2.00		
TB2517	0.75	0.875	1.00	1.125	1.250	1.375	1.437	1.50	1.625	1.750	1.875	2.00	2.125	2.250	2.375	2.500
TB2525	1.00	1.125	1.250	1.375	1.50	1.625	1.750	1.875	2.00	2.125	2.250	2.375	2.500			
TB3020	1.250	1.375	1.50	1.625	1.750	1.875	2.00	2.125	2.250	2.375	2.50	2.625	2.750	2.875	3.00	
TB3030	1.375	1.500	1.625	1.750	1.875	2.00	2.125	2.250	2.375	2.50	2.625	2.750	2.875	3.00		
TB3535	1.625	1.750	1.875	2.00	2.125	2.250	2.375	2.50	2.625	2.750	2.875	3.00	3.125	3.250	3.375	3.50
TB4040	2.00	2.125	2.250	2.375	2.50	2.625	2.750	2.875	3.00	3.125	3.250	3.375	3.50	3.625	3.750	4.00

WHEN ORDERING SPECIFY BOTH THE BUSH NUMBER AND BORE SIZE REQUIRED

Transmission Counterweight Sets

Key

1. Chain
2. Guide pulley
3. Anchor stud
4. End attachment link

Unlike link chains, transmission chains are exempt from annual annealing requirements for this type of application.

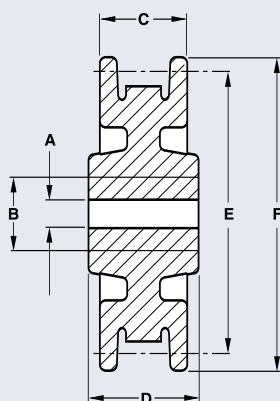
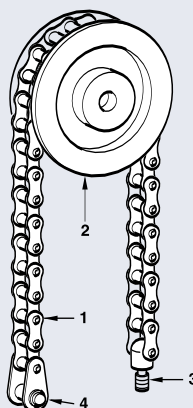

Guide Pulleys

Renold Chain No	Part No	Stock Bore	Max Bore	Width Over Flanges	Distance Through Boss	Chain Pitch Dia	Outside Dia
		A	B	C	D	E	F
STANDARD ROLLER CHAINS							
111046	661200	12	25	23	25	80.14	89
110046	661201*	12	25	28	32	85.98	95
110056	661202*	14	32	31	38	105.41	114
110066	661203*	19	35	38	45	126.37	140
110088	661204*	30	50	54	64	171.58	191
EXTENDED PITCH ROLLER CHAINS							
113083	661201	12	25	28	32	85.98	95
113103	661202	14	32	31	38	105.41	114
113123	661203	19	35	38	45	126.37	140
113168	661204	30	50	54	64	171.58	191

*Sprockets can be supplied for use with these chains.

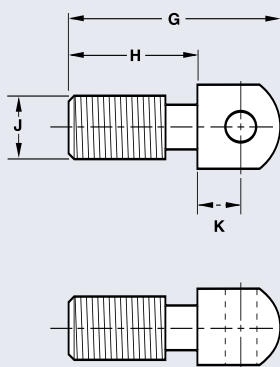

Anchor Studs

Renold Chain No	Part No	Overall Length Max	Thread Length Max	Metric Thread Size	Pin to Shoulder Max
		G	H	J	K
STANDARD ROLLER CHAINS					
111046	661031	27	16.4	M8-1.25	5.72
110046	661032	32	20	M10-1.50	6.86
110056	661033	41	26	M12-1.75	7.82
110066	661034	44	26	M16-2.00	9.14
110088	661035	62	39	M20-2.50	11.81
EXTENDED PITCH ROLLER CHAINS					
113083	661032	32	20	M10-1.50	6.86
113103	661033	41	26	M12-1.75	7.82
113123	661034	44	26	M16-2.00	9.14
113168	661035	62	39	M20-2.50	11.81

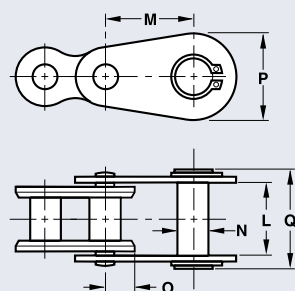

End Attachment Links

Renold Chain No	Part No	Inside Width Min	Pitch Nom	Stud Dia Max	Inner Link Head	Plate Head Max	Clearance
		L	M	N	O	P	Q
111046	111046/230	7.6	19.05	8	5.8	17	19.0
110046	110046/230	11.4	19.05	8	5.8	18.3	24.0
110056	110056/230	13.4	25.40	10	6.7	21	27.0
110066	110066/230	15.7	31.75	11	7.8	26	30.0
110088	110088/230	25.6	38.10	16	10.3	35.4	42.5

Part No. 230 comprises end attachment link riveted to an inner link (No.4) and is supplied complete. It is secured to chain by means of an outer link (No. 107).

Key

1. Chain
2. Draw bolt and block
3. Anchor plate
4. Sprocket

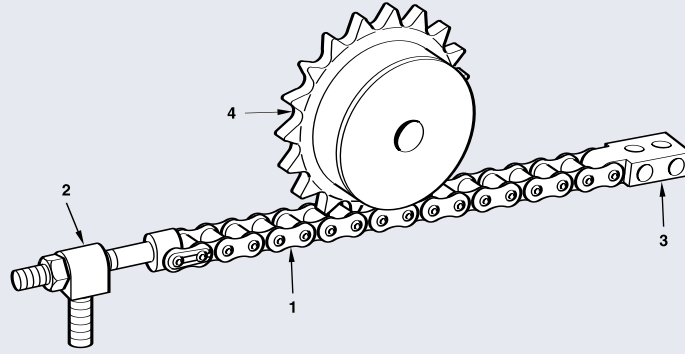

1

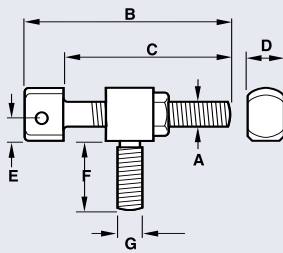

Draw Bolt and Block

Renold Chain No	Part No	Metric Thread Size A	Overall Length Max B	Length Under Head Max C	Head Width Max D	Base to Chain Centre E	Block Thread Length F	Metric Thread Size G
110046	661410	M08-1.25	63	51	11.2	5.08	19.6	M12-1.75
110056	661411	M10-1.50	78	64	13.1	7.1	26.0	M16-2.00
110066	661412	M12-1.75	90	73	15.5	8.6	26.0	M16-2.00
110088	661413	M16-2.00	126	104	25.2	11.17	39.0	M20-2.50

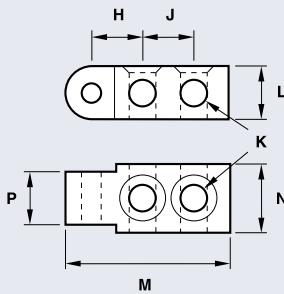

Anchor Plate

Renold Chain No	Part No	Bolt Hole to Chain Pin Nom H	Bolt Hole Pitch Nom J	Hole Dia Min K	Block Depth L	Overall Length Max M	Block Width N	Chain Width Max P
110046	661310	12.7	12.7	5.3	12.7	40	15.9	11.2
110056	661311	15.9	20.3	8.4	15.9	55	22.3	13.1
110066	661312	15.9	20.3	8.4	17.5	58	22.3	15.5
110088	661313	25.4	28.0	10.5	22.2	84	31.8	25.2

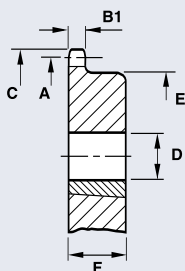

Sprockets

Renold Chain No	Part No	No. of Teeth	PCD A	Top Dia C	Bore Min	D Max	Boss Dia E	Dist' Thro' F
110046	212461	19	77.16	82	12	40	60	28
110056	213011	19	96.45	103.3	42	70	70	30
110066	213461	19	115.74	123.9	16	53	80	35
110088	214011	19	154.33	165.9	20	60	100	45

SEE PAGES 66 TO 72 FOR DIMENSION B1

Transmission Chain Guides

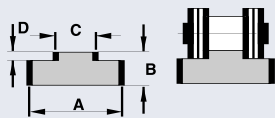

PLASTIC GUIDE RAILS HORIZONTAL - T-PROFILE

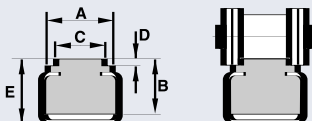

PLASTIC GUIDE RAILS STEEL REINFORCED HORIZONTAL

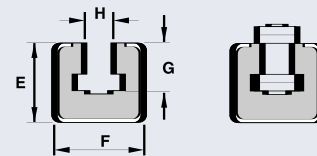

PLASTIC GUIDE RAILS STEEL REINFORCED VERTICAL

1

Plastic Guide Rails Horizontal

Chain

Technical Details

Chain ISO NO	Part No	A	B	C	D
06B-1	T1 021 510	15.0	10.0	5.5	1.5
08B-1	T1 052 010	20.0	10.0	7.5	2.2
08B-1	T1 052 015	20.0	15.0	7.5	2.2
10B-1	T1 072 010	20.0	10.0	9.3	2.6
10B-1	T1 072 015	20.0	15.0	9.3	2.6
12B-1	T1 082 515	25.0	15.0	11.3	2.4
12B-1	T1 082 520	25.0	20.0	11.3	2.4
16B-1	T1 094 015	40.0	15.0	16.5	3.5
16B-1	T1 094 020	40.0	20.0	16.5	3.5
20B-1	T1 104 515	45.0	15.0	19.0	4.2
24B-1	T1 116 015	60.0	15.0	24.7	5.5

Plastic Guide Rails Steel Reinforced Horizontal

Chain

Technical Details

Chain ISO No	Part No	A	B	C	D	E
08B-1	CT 4/1	20.0	9.0	7.5	2.2	11.0
08B-1	CT 6/2	17.0	12.0	7.5	2.2	17.0
10B-1	CT 8/2	17.0	12.0	9.3	2.6	17.0
12B-1	CT 9/2	20.0	12.0	11.3	2.4	17.0
12B-1	CT 10/3	23.5	12.0	11.3	2.4	18.0
16B-1	CT 11/3	23.5	12.0	16.5	3.5	18.0
20B-1	CT 12/3	28.0	12.0	19.0	4.3	18.0
24B-1	CT 13/5	33.0	25.0	24.7	5.5	30.0

Plastic Guide Rails Steel Reinforced Vertical

Chain

Technical Details

Chain ISO No	Part No	E	F	G	H
06B-1	CGK 1/6	24.0	30.0	8.7	6.6
08B-1	CGK 5/6	24.0	30.0	11.5	8.7
10B-1	CGK 7/6	24.0	30.0	13.5	10.4
12B-1	CGK 8/6	24.0	30.0	15.9	12.3
16B-1	CGK 9/9	40.0	45.0	25.0	16.1
20B-1	CGK 10/9	40.0	45.0	28.0	19.3

For Chain Breaking

Screw operated extractors break chain by forcing the Renold end softened bearing pins out of the outer link plates. For other brands of chain the rivet swell must first be ground away.

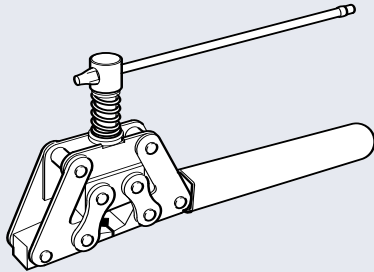

Part No. 10101
For use with chains:
9.525 mm/0.375" to 15.875 mm/0.625".
BS and ANSI Series.

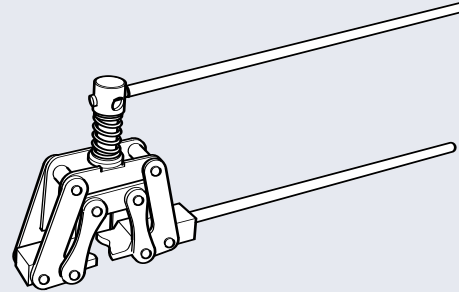

Part No. 10102
For use with chains:
19.05 mm/0.75" to 31.75 mm/1.25" BS Series.
19.05 mm/0.75" to 25.4 mm/1" ANSI Series.

Chain Lubricant

Renold Chain Lubricant has been specially formulated to ensure positive lubrication and protection to all working surfaces of the chain drive. It is fast penetrating, does not drip or fling, and is ideal for quick and easy application, particularly on open chain drives where normal lubrication is not possible.

Fast positive penetration

Does not drip or drain away

Resists centrifugal flinging

Longer chain life

Part No. 611124
For use on 'open' chain drives.