

# Hydraulic seals - linear

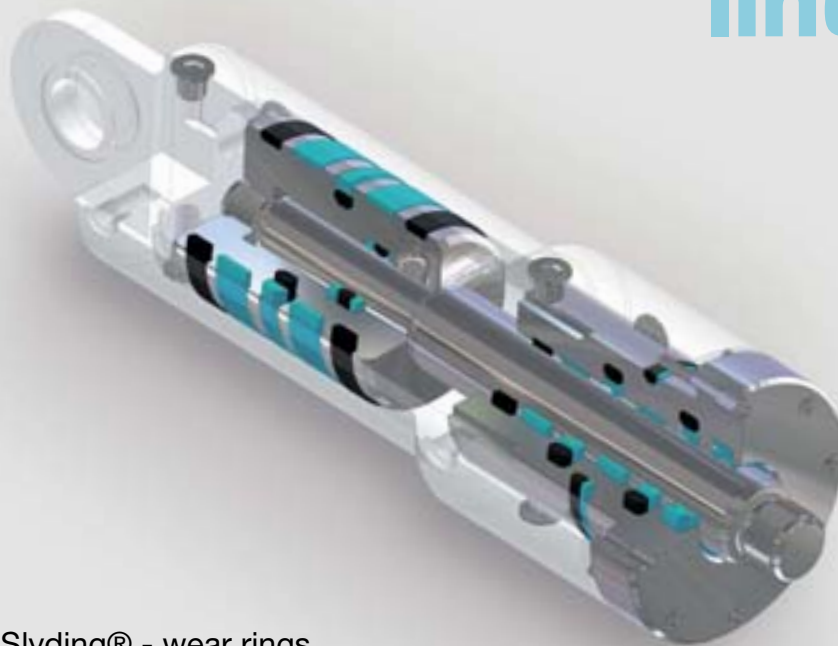

Slyding® - wear rings



**Your Partner for Sealing Technology**



## Your Partner for Sealing Technology

Trelleborg Sealing Solutions is a major international sealing force, uniquely placed to offer dedicated design and development from our market leading product and material portfolio; a one-stop shop providing the best in elastomer, thermoplastic, PTFE and composite technologies for applications in aerospace, industrial, and automotive industries.

With 50-years experience, Trelleborg Sealing Solutions engineers support customers with design, prototyping, production, test and installation using state-of-the-art design tools. An international network of over 70 facilities worldwide includes 30 manufacturing sites, 8 strategically positioned research and development centers, including materials and development laboratories and locations specializing in design and applications.

Developing and formulating materials in-house, we utilize the resource of our material database, including over 2,000 proprietary compounds and a range of unique products.

Trelleborg Sealing Solutions fulfills challenging service requirements, supplying standard parts in volume or a single custom-manufactured component, through our integrated logistical support, which effectively delivers over 40,000 sealing products to customers worldwide.

Facilities are certified to ISO 9001:2000 and ISO/TS 16949:2002, with many manufacturing sites also working to QS9000 and VDA 6.1. Trelleborg Sealing Solutions is backed by the experiences and resources of one of the world's foremost experts in polymer technology, Trelleborg AB.

**ISO 9001:2000**

**ISO/TS 16949:2002**

The information in this brochure is intended to be for general reference purposes only and is not intended to be a specific recommendation for any individual application. The application limits for pressure, temperature, speed and media given are maximum values determined in laboratory conditions. In application, due to the interaction of operating parameters, maximum values may not be achieved. It is vital therefore, that customers satisfy themselves as to the suitability of product and material for each of their individual applications. Any reliance on information is therefore at the user's own risk. In no event will Trelleborg Sealing Solutions be liable for any loss, damage, claim or expense directly or indirectly arising or resulting from the use of any information provided in this brochure. While every effort is made to ensure the accuracy of information contained herewith, Trelleborg Sealing Solutions cannot warrant the accuracy or completeness of information.

**To obtain the best recommendation for a specific application, please contact your local Trelleborg Sealing Solutions marketing company.**

This edition supersedes all previous brochures.  
This brochure or any part of it may not be reproduced without permission.

© All trademarks are the property of Trelleborg AB.  
The turquoise colour is a registered trademark of Trelleborg AB.  
© Trelleborg AB, 2007. All rights reserved.

---

# SLYDRING<sup>®</sup> - WEAR RINGS

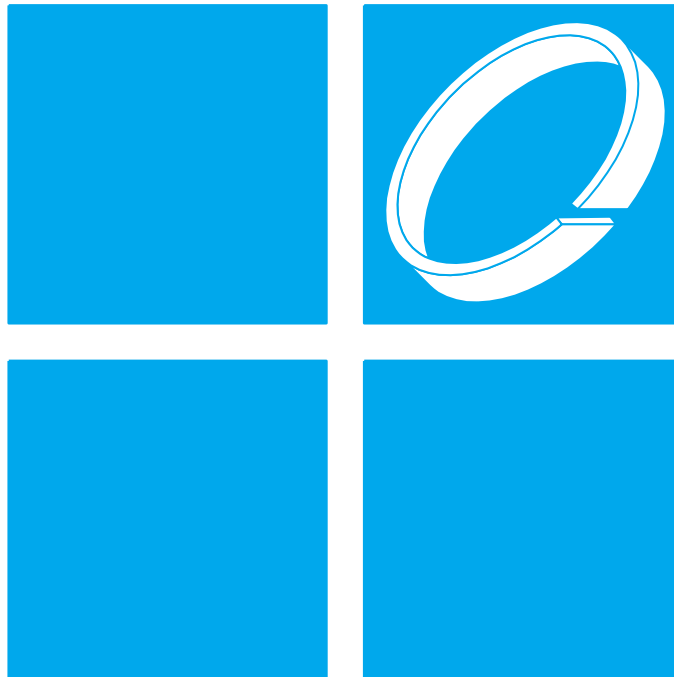





## Contents

Choice of Slydring® .....	4
Design Instructions .....	8
Turcite® and Zurcon® Slydring® for Piston and Rod .....	10
HiMod® Slydring® for Piston and Rod .....	22
Orkot® Slydring® for Piston and Rod .....	45



### ■ Choice of Slydring®

The function of Slydring® is to guide the piston and piston rod of a hydraulic cylinder and to absorb the transverse forces which occur. At the same time, metallic contact between the sliding parts of the cylinder, e.g. piston and cylinder barrel or rod and cylinder head, must be prevented. Non-metallic guide rings offer major benefits compared with the traditional metallic guides:

- Cost efficient production
- High load bearing capacity
- Eliminates local stress concentrations
- Wear-resistant, long service lives
- Metal/plastic pairing eliminates fretting and seizure
- Favourable friction behaviour
- Damping of mechanical vibrations
- Good wiping effect, embedding of foreign particles possible
- Protection of the seal against "dieseling"
- Free choice of material of the metal components as guiding properties are no longer required
- Eliminates hydrodynamic pressure problems in the guide system
- Simple closed groove, easy installation
- Low service costs

### Materials

In view of the different specific demands made on piston and rod guides, various Slydring® materials are available:

- Highly wear-resistant, low friction, specially modified Turcite® materials for low to medium duty with limited radial forces
- HiMod® materials with friction-reducing fillers for medium to heavy duty
- Orkot® fabric composite materials for heavy duty and high radial forces

In order to choose the most suitable Slydring®, it is first necessary to know all the required functional parameters. Table I can be used to make an initial preselection of the Slydring® and the materials to meet the demands of the application.

Before the final choice of Slydring® and material is made, the details and information must be checked in the relevant data sheets of Slydring® materials.



In principle, piston Slydring® and rod Slydring® are interchangeable if the difference in size is taken into consideration, e.g. piston ring, diameter 100 x 2.5 mm thick can be used as a piston rod Slydring® diameter 95 x 2.5 mm

thick. Depending on the material and dimensions of the Slydring®, the thickness tolerance is in the range of +0 to -0.08 mm.

Please do not hesitate to contact our Technical Department for further information on specific applications and special technical questions.



**Table I Selection Criteria for Slydring®**

Slydring®		Application				Standard <sup>1)</sup>	Installation	Material						
Type	Page	Field of Application			Mating Surface	ISO	Size Range mm	Recommended Slydring® Material						
			Light	Medium	Heavy									
	10	Mobile hydraulics	●	-	-	Steel	Off-the-roll up to diameter 4200	Turcite® T47						
		Standard cylinders	●	●	-	Steel, hardchromed Cast iron								
		Machine tools	●	●	-									
		Injection moulding machines	●	●	-	Mild steel Stainless steel		ISO 10766	Off-the-roll up to diameter 4200	Turcite® T51				
		Automotive industry	●	●	-	Aluminium, Bronze								
		Pneumatics	●	-	-	Mild steel				Off-the-roll up to diameter 4200	Turcite® T59			
		Water hydraulics	●	●	-	Stainless steel Aluminium, Alloys								
		Dry application	●	●	-									
		Foodstuff industry	●	●	-	Steel				ISO 10766	Off-the-roll up to diameter 4200	Zurcon® Z80 UHMWPE		
		Water hydraulics	●	●	-	Mild steel Steel, hardchromed								
		Dry application	●	●	-	Stainless steel Aluminium, Bronze								
		Pneumatics	●	●	-	Ceramic coating								
			22	Mobile hydraulics	●	●				-	Steel	ISO 10766	Rings up to diameter 300	HiMod® HM061 POM/Glass fibre
				Standard cylinders	●	●				-	Steel, hardchromed Cast iron			
Agricultural machinery	●			●	-									
Mobile hydraulics	●			●	●	Steel	ISO 10766			Rings up to diameter 300	HiMod® HM062 PA/Glass fibre + PTFE			
Standard cylinders	●			●	-	Steel, hardchromed Cast iron								
Agricultural machinery	●			●	-									
Mobile hydraulics	●			●	●	Steel		Off-the-roll up to diameter 4200	HiMod® HM063 PA/Glass fibre					
Standard cylinders	●			●	-	Steel, hardchromed Cast iron								
Agricultural machinery	●	●	-											
	45	Mobile hydraulics	-	●	●	Steel	ISO 10766	Rings up to diameter 1600 <sup>2)</sup>	Orkot® C320 Polymer/fabric					
		Standard cylinders	●	●	●	Steel, hardchromed Cast iron								
		Presses	●	●	●	Ceramic coating								
		Mobile hydraulics	-	●	●	Steel			ISO 10766	Rings up to diameter 1600 <sup>2)</sup>	Orkot® C380 Polymer/fabric			
		Standard cylinders	●	●	●	Steel, hardchromed Cast iron								
		Water hydraulics	●	●	●	Stainless steel								
		Shipping and marine engineering	●	●	●									
		Presses	●	●	●									
		Mobile hydraulics	-	●	●	Steel					Off-the-roll up to diameter 4200	Orkot® C932 Phenolic/cotton		
		Standard cylinders	●	●	●	Steel, hardchromed Cast iron								
Presses	●	●	●	Stainless steel										

1) For Slydring® to other standards, e.g. to French standard NF E 48-037, please contact us.

2) Segments made from strip material can be used for larger diameters.



# Slydring® - Wear Ring

## Forms of Supply

Two characteristics must be observed with respect to the forms of supply for Slydring®:

### - Type of cut

Figure 1 shows the angle cut which are the most frequently used standard type of cut. Rings with other types of cut are available on request. Design Code as shown in Table III.

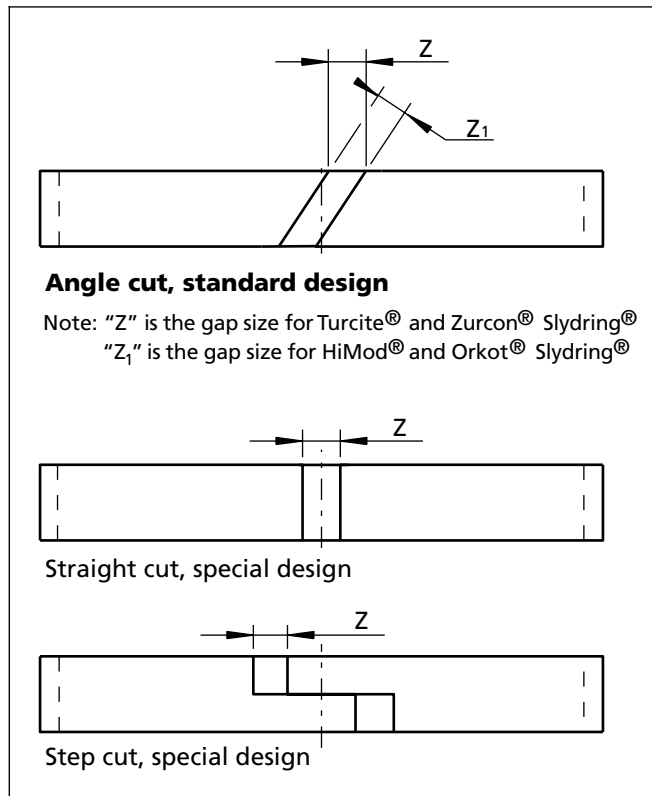

Figure 1 Type of cut

### - Design type

Slydring® have a rectangular cross-section with rounded or chamfered edges, thus preventing impermissible edge forces in the corner radii of the grooves. The chamfers also serve to facilitate installation, e.g. when inserting into the cylindrical tube or guide bush.

Slydring® are supplied ready to fit with the gap necessary (dimension Z or Z<sub>1</sub>) for their function. The ring ends are finished as standard with an angle cut.

For further details, please refer to Table II.

Slydring® are depending on material supplied as split rings and/or as strip material.

Strip material is available in rolls or pre-cut to size as listed in Table II.

**Table II Forms of Supply for Slydring®**

Material	Ring Diameter mm	Cut Strip for Diameter mm	Off-the-Roll
Turcite® T47/T51/T59	-	8 - 4200	See Table V
Zurcon® Z80	on request	30 - 4200	on request
Orkot® C320/C380	16 - 1600	300 - 2000	see page 46
Orkot® C932	16 - 500	-	-
HiMod® HM061	up to 300	-	-
HiMod® HM062	up to 300	-	-
HiMod® HM063	up to 300	-	-





**Table III Design Codes for Cut**

Material	Turcite®		Zurcon®	HiMod®	Orkot®	
	T47 T51 T59		Z80	HM061 HM062 HM063	C320 C380 C932	C320 C380
Code for cut	Strip With Teardrop structure	Strip Without Teardrop structure	Strip Without Teardrop structure	Ring Without Teardrop structure	Ring Without Teardrop structure	Strip Without Teardrop structure
Angle cut	<b>0*</b>	L	<b>0</b>	<b>0</b>	<b>0</b>	A
Straight cut	B*	D	D	<b>D**</b>	H	D
Step cut	C*	E	E	E	-	E

Design Code **0**, in bold types are the standard Slydring® versions

\* Design Code for **Turcite®** Slydring® with teardrop structure on both sides - which is standard up to and including **3 mm** radial thickness "W". See Ordering Examples.

\*\* HiMod® Wear Rings for non ISO groove dimensions have as standard a straight cut Code D.

Teardrop structure: A detailed description can be found on page 10.



## ■ Design Instructions

### Selection of Slydring®

An initial choice can be made for various applications by checking the Selection Criteria for Slydring® in Turcite®, Zurcon®, HiMod® or Orkot®, see Table I and the pages 11, 13;, 22, 23 and 45.

The values for the load on the Slydring® are valid for a load distribution as illustrated in Figure 2. The flexibility of the materials ensures a relatively constant specific load, irrespective of the size of the radial forces F, as with increasing radial loading, the guide surface subjected to the load increases also.

The radial forces which occur can vary within wide ranges and cannot always be calculated exactly in advance. For such cases, a safety factor of at least 2 is recommended when calculating (see calculation example).

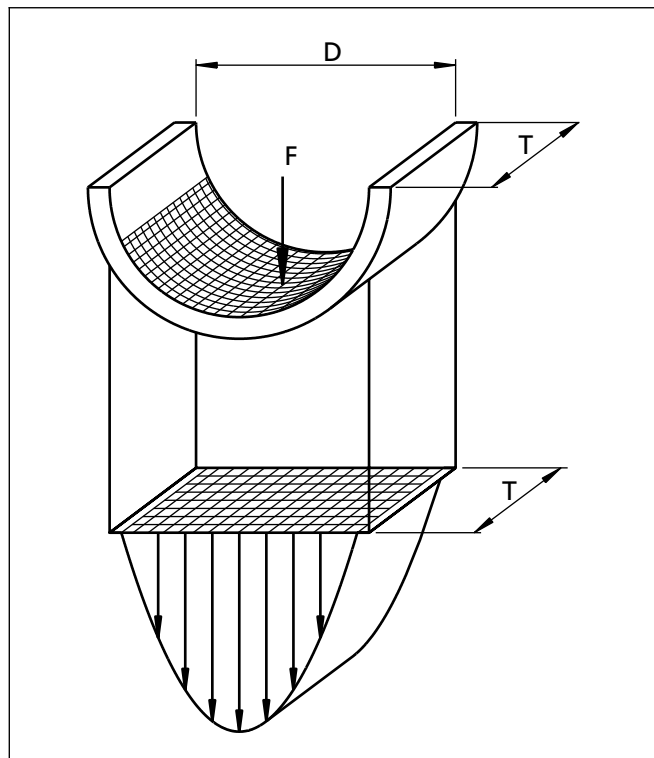

Figure 2 Load distribution

The large effective bearing area of non-metallic Slydring® gives low maximum contact pressure.

### Dimensioning of Slydring®

The radial bearing pressure and the resulting elastic deflection are important parameters in the design of the Slydring®. The radial offset resulting from the dimensional tolerances, deflection and wear should always be less than the smallest gap to be sealed by the system.

On request, we are willing to carry out dimensioning calculations for specific applications.

A rough estimate of the number and width of Slydring® required can be calculated using the following formula:

$$\text{Slydring}^{\circledR} \text{ width } T_{\text{total}} = \frac{F \times f}{d_N \times Pr}$$

where:

F = Maximum radial load [N]

f = Safety factor

d<sub>N</sub> = Rod diameter [mm]

Pr = Radial Slydring® pressure [N/mm<sup>2</sup>]

Example:

d<sub>N</sub> = 60 mm

F = 40.000 N

t = 40 °C

f = 2

Slydring® material Orkot® C 380

Pr<sub>per.</sub> = 100 N/mm<sup>2</sup>

$$T_{\text{total}} = \frac{40.000 \times 2}{60 \times 100} = 13.3 \text{ mm}$$

From Table IV, a groove with a width of 15 mm or 2 grooves with widths of 9.7 mm are selected. The installation of two strips is recommended as this gives a wider guide length.

Selected:

2 strips Series GR69 with a groove width L<sub>2</sub> = 9.7 mm



The standard installation arrangement for pistons and rods is shown in Figures 3 and 4.

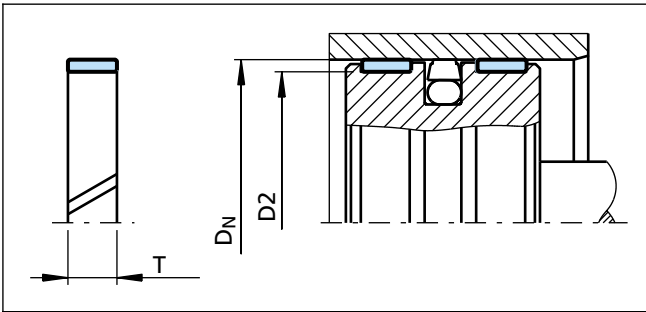

Figure 3 Piston guide

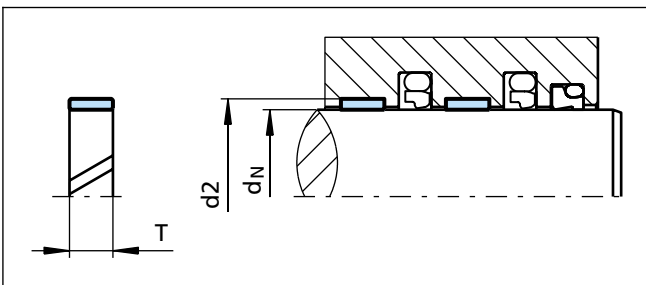

Figure 4 Rod guide

To further improve the operational safety, particularly under high loads, the installation of a 3rd strip made of material Turcite® T47 is recommended. It is installed on the oil side and serves eg as an internal scraper.

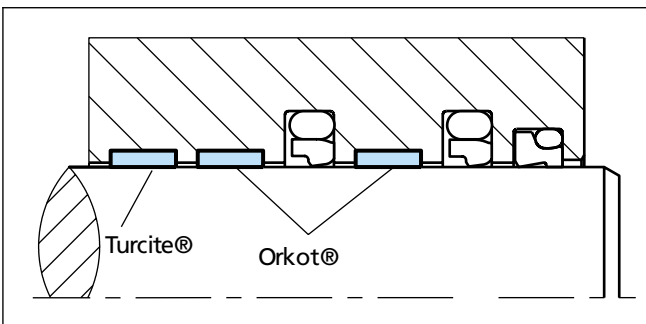

Figure 5 Rod guide for high loads  
(See also Figure 15)



## ■ Turcite® Slydring® for Piston and Rod

### Description

Turcite® Slydring® are used as piston and rod guides due to their outstanding friction behaviour, stick-slip free running and good resistance to high temperatures and chemicals.

Slydring® are available as off-the-roll materials for cutting to length in the users works as listed in Table V. Sections cut to size ready for installation is available for rod and piston diameters according to Table II.

Slydring® have a geometrically rectangular cross-section and are chamfered at the edges for easy installation into the grooves.

#### - Teardrop structure

Slydring® up to and including 3 mm radial thickness in Turcite® materials are as standard supplied with "teardrop" structure on the sliding surfaces. This structure comprises small lubricant pockets on the surface which improve the initial lubrication and promote the formation of a lubricant film. They also help to protect the seal system through their ability to embed any foreign particles. In order to be able to use the strip material for both piston and piston rod guides, the rings have this same teardrop structure on both sides.

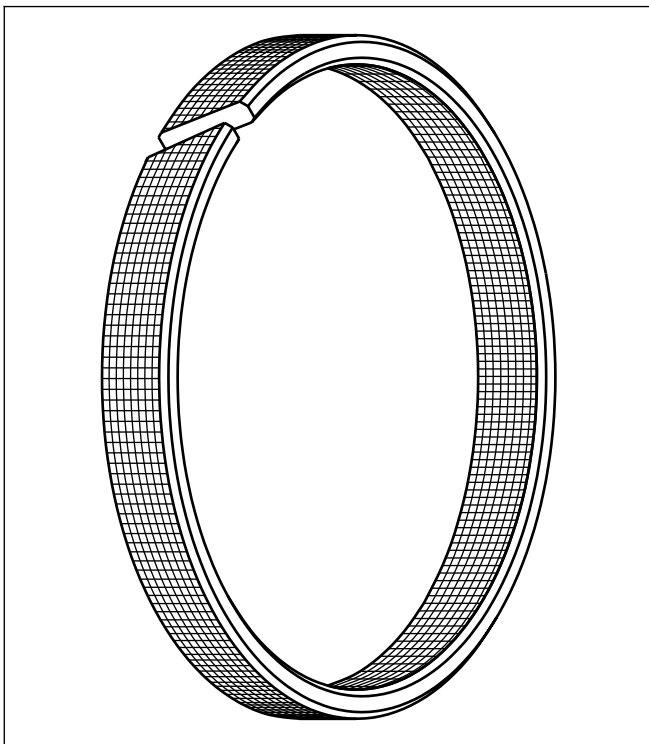

Figure 6 Turcite® Slydring® with teardrop structure

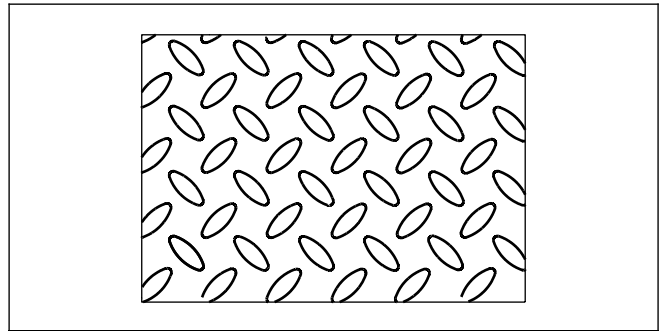

Figure 7 Teardrop structure for Turcite® Slydring®

Slydring® can also be delivered without teardrop structure. In this case, this must be indicated in the TSS Article No. (see Design Code for cut/type in Table III).

### Advantages

- Outstanding lubrication conditions further improved by the Teardrop structure
- No stick-slip effect when starting for smooth operation even at very low speeds
- Minimum static and dynamic friction coefficient for low operating temperature and energy loss
- Suitable for non lubricating fluids depending on Turcite® material for optimum design flexibility
- High wear resistance ensures long service life
- Installation grooves according to ISO 10766
- Suitable for most hydraulic fluids in relation with the majority of modern hardware materials and surface finish depending on material selected.
- Suitable for new environmentally safe hydraulic fluids
- The embedding of foreign particles is enhanced
- Good damping effect, absorbs vibrations



## Application Examples

The Turcite® Slydring® is successfully applied in demanding applications as a standard guiding element for hydraulic operated pistons, plus for piston rods with special requirements, in:

- Machine tools
- Injection moulding machines
- Press brakes
- Presses
- Robotics & Handling machinery
- Automation
- Positioning cylinders
- Servo hydraulics
- Piston accumulators
- Shock absorber
- Valves for hydraulic & pneumatic circuits
- Agriculture
- Chemical and Process Industry

## Technical Data

The Turcite® Slydring® with angle cut is recommended for reciprocating movements

Speed: up to 15m/s

Temperature: -60°C to +150°C (200°C)

Media: Mineral Oil based Hydraulic fluids, barely flammable hydraulic fluids, environmentally safe hydraulic fluids (biological degradable oils), water, air and others. Depending on the Turcite® material compatibility.

Clearance: The maximum permissible radial clearance  $s_{max}$  is depending on the actual sealing system.

### Radial Slydring®

pressure  $P_r$ : Max. 15 N/mm<sup>2</sup> at 25°C  
Max. 12 N/mm<sup>2</sup> at 80°C  
Max. 8 N/mm<sup>2</sup> at 120°C

When calculating the width of Turcite® Slydring® it is recommended to use a safety factor  $f=2$  (see page 8).

With the Turcite® materials it must be taken into account that the permissible surface pressure decreases with increasing temperatures. The load bearing ability for dynamic applications in practice is dependent primarily on the operating temperature. This should therefore generally not exceed 150°C.

### Important Note:

The above stated limits for pressure and speed are maximum values individually. Friction heat generated by the combination of pressure and speed may cause local heat built-up. Care should be taken not to apply high values for pressure and speed at the same time.

## Materials

### Standard Application:

- For hydraulic components with reciprocating movement in mineral oils or medium with good lubricating performance. Low friction, high resistance to wear, heat and chemicals:

Turcite® T47 (bronze filled)

### Special Application:

- For lubricated and poor lubricated moving components: Water hydraulics and soft metal surfaces:

Turcite® T51 (carbon filled)

- For short stroke movements, non-lubricating fluids, water hydraulics, soft metal surfaces or pneumatic, applications requiring self-lubricating sealing materials:

Turcite® T59 (carbon fiber filled)



# Turcite® Slydring® - Wear Ring

**Table IV Serial Numbers for Turcite® Slydring® in T47, T51, T59**

Piston Serial No.	Rod Serial No.	Off-the-roll Serial No.	Groove Width L <sub>2</sub>	Ring Thickness W
GP06	GR06	GM0600000-	6.00	1.00
GP22	GR22	GM2200000-	3.20	1.50
GP31	GR31	GM3100000-	10.00	1.50
GP41	GR41	GM4100000-	2.50	1.55
<b>GP43</b>	<b>GR43</b>	<b>GM4300000-</b>	<b>4.00</b>	<b>1.55</b>
GP49	GR49	GM4900000-	9.70	2.00
GP53	GR53	GM5300000-	15.00	2.00
GP64	GR64	GM6400000-	4.20	2.50
<b>GP65</b>	<b>GR65</b>	<b>GM6500000-</b>	<b>5.60</b>	<b>2.50</b>
GP67	GR67	GM6700000-	6.30	2.50
GP68	GR68	GM6800000-	8.10	2.50
<b>GP69</b>	<b>GR69</b>	<b>GM6900000-</b>	<b>9.70</b>	<b>2.50</b>
<b>GP73</b>	<b>GR73</b>	<b>GM7300000-</b>	<b>15.00</b>	<b>2.50</b>
GP74	GR74	GM7400000-	20.00	2.50
<b>GP75</b>	<b>GR75</b>	<b>GM7500000-</b>	<b>25.00</b>	<b>2.50</b>
GP76	GR76	GM7600000-	30.00	2.50
GP94	GR94	GM9400000-	20.00	3.00
<b>GP98*</b>	<b>GR98*</b>	<b>GM9800000-*</b>	<b>25.00</b>	<b>4.00</b>
GP99*	-	GM9900000-*	9.70	4.00

\* without teardrop structure. Further dimensions on request. Dimensions in **bold** are suitable for installation in grooves to ISO 10766.

**Table V Turcite® Slydring® Length of the roll**

Turcite® T47, T51, T59	Ring Thickness W
Length of the Roll	
23.0 m	1.55
13.5 m	2.50
7.0 m	4.00

Off-the-roll material can only be supplied as complete rolls.

## Turcite® from the roll, calculation of the Linear Length

The linear length of Turcite® and Zurcon® is calculated such that a gap "Z" is created at the ends of the strip after installation (see Figure 3 and 4). This is required for the following reasons:

- Compensation of the linear expansion of the strips due to the effects of temperature
- Avoidance of intermediate pressures and entrained pressures.

When ordering strips off-the-roll for manufacturing of Turcite® and Zurcon® Slydring® in your own works, the length of the strip can be calculated using the following formulae:

Piston Slydring®:

$$L = c \times (D_N - W) - k \text{ [mm]}$$

Rod Slydring®:

$$L = c \times (d_N + W) - k \text{ [mm]}$$

D<sub>N</sub> = Bore diameter [mm]

d<sub>N</sub> = Rod diameter [mm]

W = Ring thickness [mm]

c = 3.11 material factor, valid for Turcite® and Zurcon® Materials

k = Temperature constant:  
0.8 for operating temperatures up to 120° C.

2.0 only for applications > 120° C.

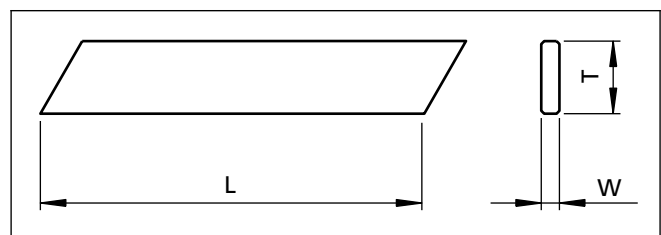

Figure 8 Cut length



## ■ Zurcon® Slydring® for Piston and Rod

### Zurcon® Z80

Z80 is a UHMW-PE (ultra high molecular weight polyethylene) material which meets the requirements in FDA 21 CFR 177.1520 and is therefore recommended for use in foodstuff applications. The material is also preferred for use in water hydraulics and pneumatics due to excellent friction and wear properties.

#### Advantages:

- Good lubrication and wear performance
- Self-lubricating
- Low friction value
- No water absorption
- In compliance with FDA
- Excellent resistance to chemicals
- High wear resistance.

#### Application Examples

- Water hydraulics
- Dry pneumatics
- Filling machines
- Food processing
- Medical equipment
- Ceramic coated hydraulics

#### Technical Data

Velocity, reciprocating: Max. 2.0 m/s

Temperature: -60°C to +80°C (100°C)

Radial Slydring®  
pressure Pr: Max. 25 N/mm<sup>2</sup> at 25°C  
Max. 10 N/mm<sup>2</sup> from 60°C  
to 80°C

When calculating the width of Zurcon® Slydring® it is recommended to use a safety factor f=2 (see page 8).

#### Important Note:

The above stated limits for pressure and speed are maximum values individually. Friction heat generated by the combination of pressure and speed may cause local heat built-up. Care should be taken not to apply high values for pressure and speed at the same time.

**Table VI Serial Numbers for Slydring® of Material Zurcon® Z80**

Piston Serial No.	Rod Serial No.	Off-the-roll TSS Article No.	Groove Width	Ring Thickness
			L <sub>2</sub>	W
GP41	GR41	GM4100000-Z80	2.50	1.55
GP43	GR43	GM4300000-Z80	4.00	1.55
GP65	GR65	GM6500000-Z80	5.60	2.50
GP69	GR69	GM6900000-Z80	9.70	2.50
GP73	GR73	GM7300000-Z80	15.00	2.50
GP75	GR75	GM7500000-Z80	25.00	2.50

Further dimensions on request.

**Table VII Zurcon® Z80 Slydring® Length of the Roll**

Zurcon® Z80	Ring Thickness
Length of the Roll	W
23.0 m	1.55
13.5 m	2.50

Off-the-roll material can only be supplied as complete rolls.

Zurcon® from the roll, calculation of the linear length, see page 12



## Installation Recommendation, Turcite® and Zurcon® Slydring® for Piston According to ISO 10766 Groove Dimensions

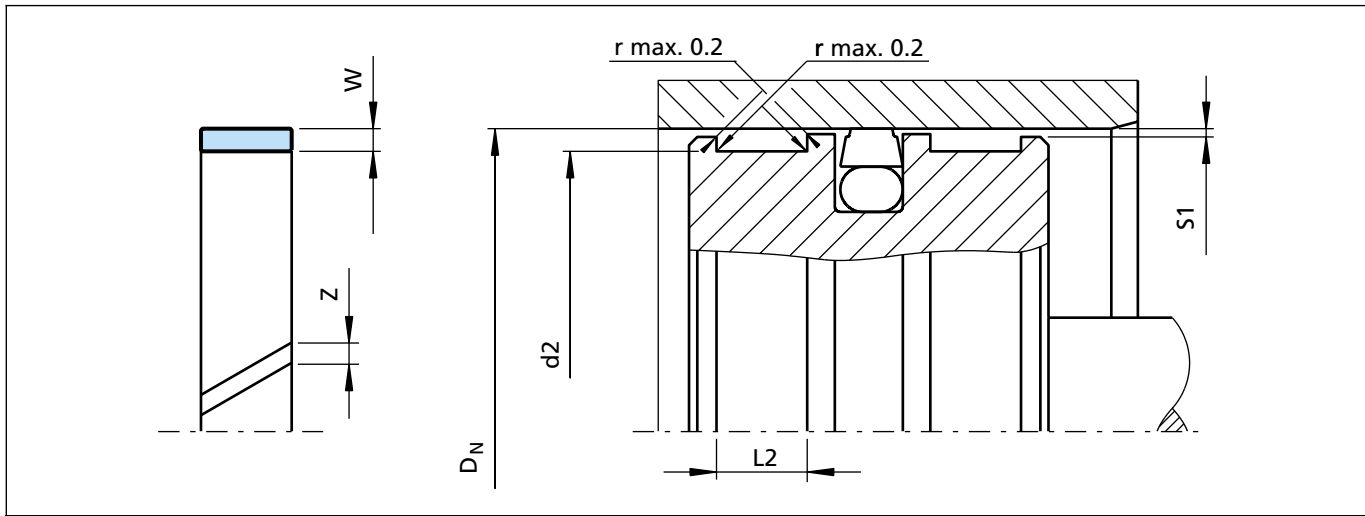

Figure 9 Installation drawing

Table VIII Installation Dimensions

Serial No.	Bore Diameter <sup>1)</sup>	Groove Diameter	Groove Width	Ring Thickness	Ring Gap
	$D_N$ H9	$d_2$ h8	$L_2 +0.2$	$W$	$Z$
GP41	8 - 20.0	$D_N -3.10$	2.50	1.55	<sup>3)</sup>
GP43	10 - 50.0	$D_N -3.10$	4.00	1.55	<sup>3)</sup>
GP65	16 - 140.0	$D_N -5.00$	5.60	2.50	<sup>3)</sup>
GP69	60 - 220.0	$D_N -5.00$	9.70	2.50	<sup>3)</sup>
GP73	130 - 400.0	$D_N -5.00$	15.00	2.50	<sup>3)</sup>
GP75	280 - 999.9	$D_N -5.00$	25.00	2.50	<sup>3)</sup>
GP75X	1000-4200.0	$D_N -5.00$	25.00	2.50	<sup>3)</sup>
GP98	280 - 999.9	$D_N -8.00$	25.00	4.00	<sup>3)</sup>
GP98X	1000-2200.0	$D_N -8.00$	25.00	4.00	<sup>3)</sup>
GP99 <sup>2)</sup>	100 - 999.9	$D_N -8.00$	9.70	4.00	<sup>3)</sup>

<sup>1)</sup> Recommended diameter ranges.

<sup>2)</sup> Non ISO 10766 standard.

<sup>3)</sup> Calculation of the linear length, see page 12

For Slydring® to other standards, e.g French standard NF E 48-037, please contact us.

<sup>4)</sup> Specifications valid only in the area of the Slydring®, but not for the seal area.

Table IX Radial Clearance  $S_1$ <sup>4)</sup>

Bore Dia. $D_N$	$S_1$ min.	$S_1$ max.
8 - 20	0.20	0.30
20 - 100	0.25	0.40
101 - 250	0.30	0.60
251 - 500	0.40	0.80
501 - 1000	0.50	1.10
>1001	0.60	1.20

Table X Surface Roughness

Parameter	Mating Surface $\mu\text{m}$		Groove Surface $\mu\text{m}$
	Turcite® Materials	Zurcon® Materials	
$R_{\text{max}}$	0.63 - 4.00	1.00 - 4.00	< 16.0
$R_z$ DIN	0.40 - 2.50	0.63 - 2.50	< 10.0
$R_a$	0.05 - 0.40	0.10 - 0.40	< 2.5





## Ordering Example

Slydring® for piston diameter  $D_N = 100.0$  mm  
 Series GP 69 from Table VIII  
 Groove width: 9.70 mm, ring thickness: 2.50 mm

Material: Turcite® T47  
 (other materials see Table I)

Standard design: With angle cut and teardrop structure  
 Design code: 0

TSS Part No.: GP6901000 (from Table XI)

The TSS Article No. can be formed from the example below.

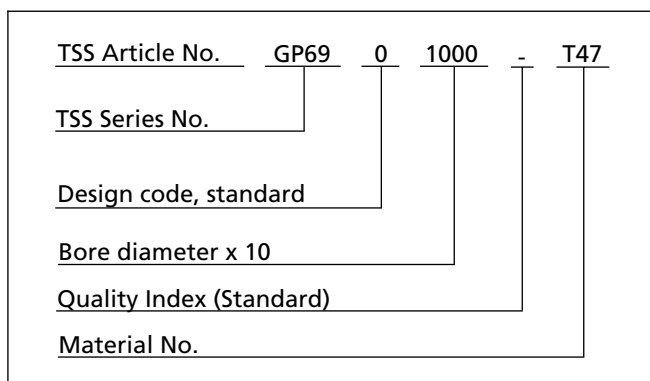

## Ordering Example for $D_N \geq 1000$ mm

Slydring® for bore diameter  $D_N = 2200.0$  mm  
 Series GP98X from Table VIII  
 Groove width: 25.00 mm, ring thickness: 4.00 mm

TSS Part No.: GP98X2200 (from Table XI)

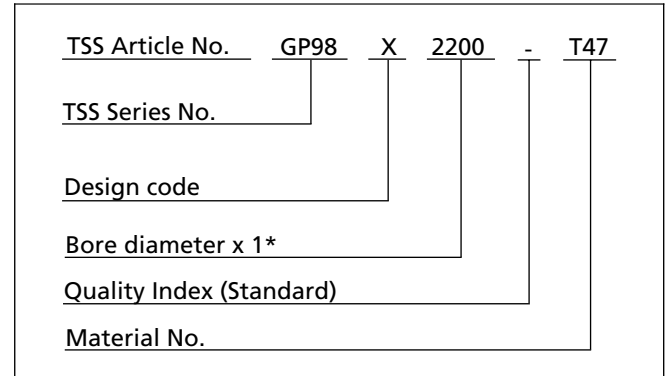

\* For diameters  $\geq 1000.0$  mm multiply only by factor 1.

**Table XI Slydring® for Piston**

Dimensions				TSS Part No.
Bore Diameter	Groove Diameter	Groove Width	Thick-ness	
$D_N$ H9	$d_2$ h8	$L_2 +0.2$	$W$	
8.0	4.9	2.5	1.55	GP4100080
10.0	6.9	2.5	1.55	GP4100100
10.0	6.9	4.0	1.55	GP4300100
12.0	8.9	4.0	1.55	GP4300120
14.0	10.9	4.0	1.55	GP4300140
15.0	11.9	4.0	1.55	GP4300150
<b>16.0</b>	<b>12.9</b>	<b>4.0</b>	<b>1.55</b>	<b>GP4300160</b>
<b>16.0</b>	<b>11.0</b>	<b>5.6</b>	<b>2.50</b>	<b>GP6500160</b>
18.0	14.9	4.0	1.55	GP4300180
18.0	13.0	5.6	2.50	GP6500180
<b>20.0</b>	<b>16.9</b>	<b>4.0</b>	<b>1.55</b>	<b>GP4300200</b>
<b>20.0</b>	<b>15.0</b>	<b>5.6</b>	<b>2.50</b>	<b>GP6500200</b>

Dimensions				TSS Part No.
Bore Diameter	Groove Diameter	Groove Width	Thick-ness	
$D_N$ H9	$d_2$ h8	$L_2 +0.2$	$W$	
22.0	17.0	5.6	2.50	GP6500220
<b>25.0</b>	<b>21.9</b>	<b>4.0</b>	<b>1.55</b>	<b>GP4300250</b>
<b>25.0</b>	<b>20.0</b>	<b>5.6</b>	<b>2.50</b>	<b>GP6500250</b>
25.0	20.0	9.7	2.50	GP6900250
27.0	22.0	5.6	2.50	GP6500270
27.0	22.0	9.7	2.50	GP6900270
28.0	23.0	5.6	2.50	GP6500280
30.0	26.9	4.0	1.55	GP4300300
30.0	25.0	5.6	2.50	GP6500300
30.0	25.0	9.7	2.50	GP6900300
<b>32.0</b>	<b>28.9</b>	<b>4.0</b>	<b>1.55</b>	<b>GP4300320</b>
<b>32.0</b>	<b>27.0</b>	<b>5.6</b>	<b>2.50</b>	<b>GP6500320</b>



# Turcite® and Zurcon® Slydring® - Wear Ring

Dimensions				TSS Part No.
Bore Diameter	Groove Diameter	Groove Width	Thick-ness	
D <sub>N</sub> H9	d <sub>2</sub> h8	L <sub>2</sub> +0.2	W	
32.0	27.0	9.7	2.50	GP6900320
33.0	28.0	5.6	2.50	GP6500330
35.0	30.0	5.6	2.50	GP6500350
35.0	30.0	9.7	2.50	GP6900350
36.0	31.9	4.0	1.55	GP4300360
37.0	32.0	5.6	2.50	GP6500370
37.0	32.0	9.7	2.50	GP6900370
<b>40.0</b>	<b>36.9</b>	<b>4.0</b>	<b>1.55</b>	<b>GP4300400</b>
<b>40.0</b>	<b>35.0</b>	<b>5.6</b>	<b>2.50</b>	<b>GP6500400</b>
40.0	35.0	9.7	2.50	GP6900400
41.0	36.0	5.6	2.50	GP6500410
41.0	36.0	9.7	2.50	GP6900410
42.0	37.0	5.6	2.50	GP6500420
45.0	40.0	5.6	2.50	GP6500450
45.0	40.0	9.7	2.50	GP6900450
48.0	43.0	5.6	2.50	GP6500480
<b>50.0</b>	<b>46.9</b>	<b>4.0</b>	<b>1.55</b>	<b>GP4300500</b>
<b>50.0</b>	<b>45.0</b>	<b>5.6</b>	<b>2.50</b>	<b>GP6500500</b>
50.0	45.0	9.7	2.50	GP6900500
52.0	47.0	5.6	2.50	GP6500520
55.0	50.0	5.6	2.50	GP6500550
55.0	50.0	9.7	2.50	GP6900550
60.0	55.0	5.6	2.50	GP6500600
60.0	55.0	9.7	2.50	GP6900600
61.0	56.0	5.6	2.50	GP6500610
62.0	56.0	9.7	2.50	GP6900610
<b>63.0</b>	<b>58.0</b>	<b>5.6</b>	<b>2.50</b>	<b>GP6500630</b>
<b>63.0</b>	<b>58.0</b>	<b>9.7</b>	<b>2.50</b>	<b>GP6900630</b>
65.0	60.0	5.6	2.50	GP6500650
65.0	60.0	9.7	2.50	GP6900650
68.0	63.0	5.6	2.50	GP6500680
68.0	63.0	9.7	2.50	GP6900680
70.0	65.0	5.6	2.50	GP6500700
70.0	65.0	9.7	2.50	GP6900700
72.0	67.0	5.6	2.50	GP6500720
75.0	70.0	5.6	2.50	GP6500750

Dimensions				TSS Part No.
Bore Diameter	Groove Diameter	Groove Width	Thick-ness	
D <sub>N</sub> H9	d <sub>2</sub> h8	L <sub>2</sub> +0.2	W	
75.0	70.0	9.7	2.50	GP6900750
<b>80.0</b>	<b>75.0</b>	<b>5.6</b>	<b>2.50</b>	<b>GP6500800</b>
<b>80.0</b>	<b>75.0</b>	<b>9.7</b>	<b>2.50</b>	<b>GP6900800</b>
85.0	80.0	5.6	2.50	GP6500850
85.0	80.0	9.7	2.50	GP6900850
90.0	85.0	5.6	2.50	GP6500900
90.0	85.0	9.7	2.50	GP6900900
95.0	90.0	5.6	2.50	GP6500950
95.0	90.0	9.7	2.50	GP6900950
<b>100.0</b>	<b>95.0</b>	<b>5.6</b>	<b>2.50</b>	<b>GP6501000</b>
<b>100.0</b>	<b>95.0</b>	<b>9.7</b>	<b>2.50</b>	<b>GP6901000</b>
105.0	100.0	5.6	2.50	GP6501050
105.0	100.0	9.7	2.50	GP6901050
110.0	105.0	9.7	2.50	GP6901100
115.0	110.0	9.7	2.50	GP6901150
120.0	115.0	9.7	2.50	GP6901200
<b>125.0</b>	<b>120.0</b>	<b>5.6</b>	<b>2.50</b>	<b>GP6501250</b>
<b>125.0</b>	<b>120.0</b>	<b>9.7</b>	<b>2.50</b>	<b>GP6901250</b>
130.0	125.0	9.7	2.50	GP6901300
130.0	125.0	15.0	2.50	GP7301300
135.0	130.0	9.7	2.50	GP6901350
135.0	130.0	15.0	2.50	GP7301350
<b>140.0</b>	<b>135.0</b>	<b>9.7</b>	<b>2.50</b>	<b>GP6901400</b>
<b>140.0</b>	<b>135.0</b>	<b>15.0</b>	<b>2.50</b>	<b>GP7301400</b>
150.0	145.0	15.0	2.50	GP7301500
<b>160.0</b>	<b>155.0</b>	<b>9.7</b>	<b>2.50</b>	<b>GP6901600</b>
<b>160.0</b>	<b>155.0</b>	<b>15.0</b>	<b>2.50</b>	<b>GP7301600</b>
170.0	165.0	15.0	2.50	GP7301700
<b>180.0</b>	<b>175.0</b>	<b>9.7</b>	<b>2.50</b>	<b>GP6901800</b>
<b>180.0</b>	<b>175.0</b>	<b>15.0</b>	<b>2.50</b>	<b>GP7301800</b>
190.0	185.0	15.0	2.50	GP7301900
<b>200.0</b>	<b>195.0</b>	<b>9.7</b>	<b>2.50</b>	<b>GP6902000</b>
<b>200.0</b>	<b>195.0</b>	<b>15.0</b>	<b>2.50</b>	<b>GP7302000</b>
210.0	205.0	15.0	2.50	GP7302100
<b>220.0</b>	<b>215.0</b>	<b>9.7</b>	<b>2.50</b>	<b>GP6902200</b>
<b>220.0</b>	<b>215.0</b>	<b>15.0</b>	<b>2.50</b>	<b>GP7302200</b>



Dimensions				TSS Part No.
Bore Diameter	Groove Diameter	Groove Width	Thick-ness	
$D_N$ H9	$d_2$ h8	$L_2$ +0.2	W	
230.0	225.0	15.0	2.50	GP7302300
240.0	235.0	15.0	2.50	GP7302400
<b>250.0</b>	<b>245.0</b>	<b>9.7</b>	<b>2.50</b>	<b>GP6902500</b>
<b>250.0</b>	<b>245.0</b>	<b>15.0</b>	<b>2.50</b>	<b>GP7302500</b>
<b>280.0</b>	<b>275.0</b>	<b>15.0</b>	<b>2.50</b>	<b>GP7302800</b>
<b>280.0</b>	<b>275.0</b>	<b>25.0</b>	<b>2.50</b>	<b>GP7502800</b>
<b>280.0</b>	<b>272.0</b>	<b>25.0</b>	<b>4.00</b>	<b>GP9802800</b>
300.0	295.0	15.0	2.50	GP7303000
<b>320.0</b>	<b>315.0</b>	<b>15.0</b>	<b>2.50</b>	<b>GP7303200</b>
<b>320.0</b>	<b>315.0</b>	<b>25.0</b>	<b>2.50</b>	<b>GP7503200</b>
<b>320.0</b>	<b>312.0</b>	<b>25.0</b>	<b>4.00</b>	<b>GP9803200</b>
350.0	345.0	25.0	2.50	GP7503500
<b>360.0</b>	<b>355.0</b>	<b>15.0</b>	<b>2.50</b>	<b>GP7303600</b>
<b>360.0</b>	<b>355.0</b>	<b>25.0</b>	<b>2.50</b>	<b>GP7503600</b>
<b>360.0</b>	<b>352.0</b>	<b>25.0</b>	<b>4.00</b>	<b>GP9803600</b>
<b>400.0</b>	<b>395.0</b>	<b>15.0</b>	<b>2.50</b>	<b>GP7304000</b>
<b>400.0</b>	<b>395.0</b>	<b>25.0</b>	<b>2.50</b>	<b>GP7504000</b>
<b>400.0</b>	<b>392.0</b>	<b>25.0</b>	<b>4.00</b>	<b>GP9804000</b>
<b>450.0</b>	<b>445.0</b>	<b>15.0</b>	<b>2.50</b>	<b>GP7304500</b>
<b>450.0</b>	<b>445.0</b>	<b>25.0</b>	<b>2.50</b>	<b>GP7504500</b>
<b>450.0</b>	<b>442.0</b>	<b>25.0</b>	<b>4.00</b>	<b>GP9804500</b>
<b>500.0</b>	<b>495.0</b>	<b>15.0</b>	<b>2.50</b>	<b>GP7305000</b>
<b>500.0</b>	<b>495.0</b>	<b>25.0</b>	<b>2.50</b>	<b>GP7505000</b>
<b>500.0</b>	<b>492.0</b>	<b>25.0</b>	<b>4.00</b>	<b>GP9805000</b>
1000.0	995.0	25.0	2.50	GP75X1000
2700.0	2695.0	25.0	2.50	GP75X2700
4200.0	4195.0	25.0	2.50	GP75X4200

Zurcon® Z80 is not available as GP98, GP98X and GP99 (Thickness W=4.0 mm)

All sizes printed in **bold** type conform to ISO 10766 and should be preferred for use.

All intermediate sizes not contained in the table are available.



## ■ Installation Recommendation, Turcite® and Zurcon® Slydring® for Rod According to ISO 10766 Groove Dimension

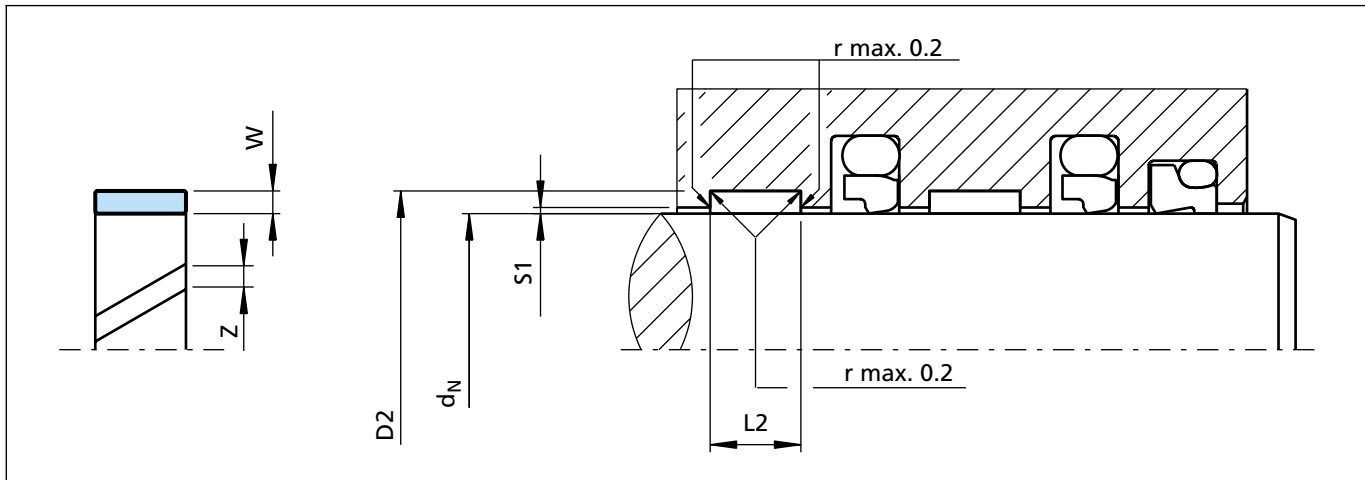

Figure 10 Installation drawing

**Table XII Installation Dimensions**

Serial No.	Rod Diameter <sup>1)</sup>	Groove Diameter	Groove Width	Ring Thickness	Ring Gap
	$d_N$ f8/h9	$D_2$ H8	$L_2$ +0.2	$W$	$Z$
GR41	8 - 20.0	$d_N$ +3.10	2.50	1.55	<sup>2)</sup>
GR43	10 - 50.0	$d_N$ +3.10	4.00	1.55	<sup>2)</sup>
GR65	15 - 140.0	$d_N$ +5.00	5.60	2.50	<sup>2)</sup>
GR69	20 - 220.0	$d_N$ +5.00	9.70	2.50	<sup>2)</sup>
GR73	80 - 400.0	$d_N$ +5.00	15.00	2.50	<sup>2)</sup>
GR75	200 - 999.9	$d_N$ +5.00	25.00	2.50	<sup>2)</sup>
GR75X	1000-4200.0	$d_N$ +5.00	25.00	2.50	<sup>2)</sup>
GR98	280 - 999.9	$d_N$ +8.00	25.00	4.00	<sup>2)</sup>
GR98X	1000-2200.0	$d_N$ +8.00	25.00	4.00	<sup>2)</sup>

<sup>1)</sup> Recommended diameter ranges. <sup>2)</sup> Calculation of the linear length, see page 12

For Slydring® to other standards, e.g French standard NF E 48-037, please contact us.

**Table XIII Radial Clearance  $S_1$ <sup>3)</sup>**

Rod Dia. $d_N$	$S_1$ min.	$S_1$ max.
8 - 20	0.20	0.30
20 - 100	0.25	0.40
101 - 250	0.30	0.60
251 - 500	0.40	0.80
501 - 1000	0.50	1.10
>1001	0.60	1.20

<sup>3)</sup> Specifications valid only in the area of the Slydring®, but not for the seal area.

**Table XIV Surface Roughness**

Parameter	Mating Surface $\mu\text{m}$		Groove Surface $\mu\text{m}$
	Turcite® Materials	Zurcon® Materials	
$R_{max}$	0.63 - 4.00	1.00 - 4.00	< 16.0
$R_z$ DIN	0.40 - 2.50	0.63 - 2.50	< 10.0
$R_a$	0.05 - 0.40	0.10 - 0.40	< 2.5



The TSS Article No. can be formed from the example below.

### Ordering Example

Slydring® for rod diameter  $d_N = 63.0$  mm  
 Series GR 65 from Table XII  
 Groove width: 5.60 mm, ring thickness: 2.50 mm

Material: Turcite® T47  
 (other materials see Table I)

Standard design: With angle cut and teardrop structure  
 Design code: 0

TSS Part No.: GR6500630 (from Table XV)

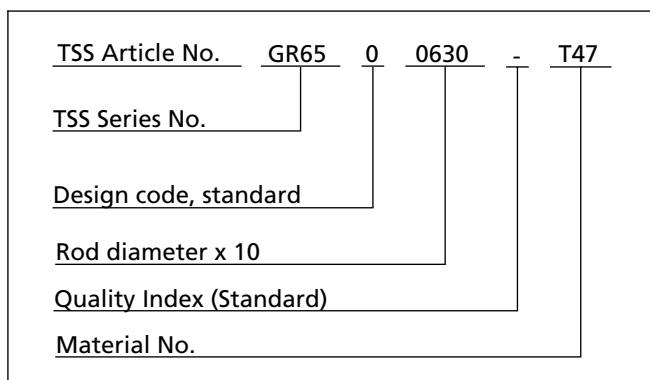

### Ordering Example for $d_N \geq 1000$ mm

Slydring® for rod diameter  $d_N = 2600.0$  mm  
 Series GR75X from Table XII  
 Groove width: 25.00 mm, ring thickness: 2.50 mm

TSS Part No.: GR75X2600 (from Table XV)

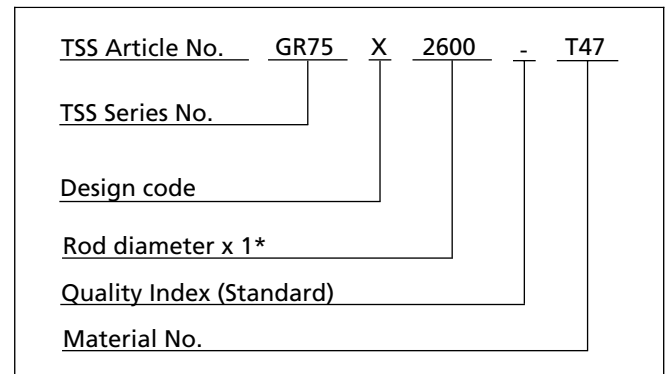

\* For diameters  $\geq 1000.0$  mm multiply only by factor 1.

**Table XV Slydring® for Rods**

Dimensions				TSS Part No.
Rod Diameter	Groove Diameter	Groove Width	Thick-ness	
$d_N$ f8/h9	$D_2$ H8	$L_2$ +0.2	W	
8.0	11.1	2.5	1.55	GR4100080
10.0	13.1	2.5	1.55	GR4100100
10.0	13.1	4.0	1.55	GR4300100
<b>12.0</b>	<b>15.1</b>	<b>4.0</b>	<b>1.55</b>	<b>GR4300120</b>
<b>14.0</b>	<b>17.1</b>	<b>4.0</b>	<b>1.55</b>	<b>GR4300140</b>
15.0	18.1	4.0	1.55	GR4300150
<b>16.0</b>	<b>19.1</b>	<b>4.0</b>	<b>1.55</b>	<b>GR4300160</b>
16.0	21.0	5.6	2.50	GR6500160
<b>18.0</b>	<b>21.1</b>	<b>4.0</b>	<b>1.55</b>	<b>GR4300180</b>
18.0	23.0	5.6	2.50	GR6500180
<b>20.0</b>	<b>23.1</b>	<b>4.0</b>	<b>1.55</b>	<b>GR4300200</b>
20.0	25.0	5.6	2.50	GR6500200
20.0	25.0	9.7	2.50	GR6900200
<b>22.0</b>	<b>25.1</b>	<b>4.0</b>	<b>1.55</b>	<b>GR4300220</b>
22.0	27.0	5.6	2.50	GR6500220

Dimensions				TSS Part No.
Rod Diameter	Groove Diameter	Groove Width	Thick-ness	
$d_N$ f8/h9	$D_2$ H8	$L_2$ +0.2	W	
22.0	27.0	9.7	2.50	GR6900220
<b>25.0</b>	<b>28.1</b>	<b>4.0</b>	<b>1.55</b>	<b>GR4300250</b>
<b>25.0</b>	<b>30.0</b>	<b>5.6</b>	<b>2.50</b>	<b>GR6500250</b>
25.0	30.0	9.7	2.50	GR6900250
27.0	32.0	5.6	2.50	GR6500270
27.0	32.0	9.7	2.50	GR6900270
<b>28.0</b>	<b>31.1</b>	<b>4.0</b>	<b>1.55</b>	<b>GR4300280</b>
<b>28.0</b>	<b>33.0</b>	<b>5.6</b>	<b>2.50</b>	<b>GR6500280</b>
28.0	33.0	9.7	2.50	GR6900280
30.0	35.0	5.6	2.50	GR6500300
30.0	35.0	9.7	2.50	GR6900300
<b>32.0</b>	<b>37.0</b>	<b>5.6</b>	<b>2.50</b>	<b>GR6500320</b>
<b>32.0</b>	<b>37.0</b>	<b>9.7</b>	<b>2.50</b>	<b>GR6900320</b>
35.0	40.0	5.6	2.50	GR6500350
35.0	40.0	9.7	2.50	GR6900350



# Turcite® and Zurcon® Slydring® - Wear Ring

Dimensions				TSS Part No.
Rod Diameter	Groove Diameter	Groove Width	Thick-ness	
d <sub>N</sub> f8/h9	D <sub>2</sub> H8	L <sub>2</sub> +0.2	W	
<b>36.0</b>	<b>41.0</b>	<b>5.6</b>	<b>2.50</b>	<b>GR6500360</b>
<b>36.0</b>	<b>41.0</b>	<b>9.7</b>	<b>2.50</b>	<b>GR6900360</b>
<b>40.0</b>	<b>45.0</b>	<b>5.6</b>	<b>2.50</b>	<b>GR6500400</b>
<b>40.0</b>	<b>45.0</b>	<b>9.7</b>	<b>2.50</b>	<b>GR6900400</b>
40.0	45.0	15.0	2.50	GR7300400
42.0	47.0	5.6	2.50	GR6500420
43.0	48.0	5.6	2.50	GR6500430
<b>45.0</b>	<b>50.0</b>	<b>5.6</b>	<b>2.50</b>	<b>GR6500450</b>
<b>45.0</b>	<b>50.0</b>	<b>9.7</b>	<b>2.50</b>	<b>GR6900450</b>
48.0	53.0	5.6	2.50	GR6500480
48.0	53.0	9.7	2.50	GR6900480
<b>50.0</b>	<b>55.0</b>	<b>5.6</b>	<b>2.50</b>	<b>GR6500500</b>
<b>50.0</b>	<b>55.0</b>	<b>9.7</b>	<b>2.50</b>	<b>GR6900500</b>
52.0	57.0	5.6	2.50	GR6500520
52.0	57.0	9.7	2.50	GR6900520
55.0	60.0	5.6	2.50	GR6500550
55.0	60.0	9.7	2.50	GR6900550
<b>56.0</b>	<b>61.0</b>	<b>5.6</b>	<b>2.50</b>	<b>GR6500560</b>
<b>56.0</b>	<b>61.0</b>	<b>9.7</b>	<b>2.50</b>	<b>GR6900560</b>
58.0	63.0	5.6	2.50	GR6500580
58.0	63.0	9.7	2.50	GR6900580
60.0	65.0	5.6	2.50	GR6500600
60.0	65.0	9.7	2.50	GR6900600
<b>63.0</b>	<b>68.0</b>	<b>5.6</b>	<b>2.50</b>	<b>GR6500630</b>
<b>63.0</b>	<b>68.0</b>	<b>9.7</b>	<b>2.50</b>	<b>GR6900630</b>
63.0	68.0	15.0	2.50	GR7300630
65.0	70.0	5.6	2.50	GR6500650
65.0	70.0	9.7	2.50	GR6900650
<b>70.0</b>	<b>75.0</b>	<b>5.6</b>	<b>2.50</b>	<b>GR6500700</b>
<b>70.0</b>	<b>75.0</b>	<b>9.7</b>	<b>2.50</b>	<b>GR6900700</b>
70.0	75.0	15.0	2.50	GR7300700
75.0	80.0	5.6	2.50	GR6500750
75.0	80.0	9.7	2.50	GR6900750
75.0	80.0	15.0	2.50	GR7300750
80.0	85.0	5.6	2.50	GR6500800
<b>80.0</b>	<b>85.0</b>	<b>9.7</b>	<b>2.50</b>	<b>GR6900800</b>

Dimensions				TSS Part No.
Rod Diameter	Groove Diameter	Groove Width	Thick-ness	
d <sub>N</sub> f8/h9	D <sub>2</sub> H8	L <sub>2</sub> +0.2	W	
<b>80.0</b>	<b>85.0</b>	<b>15.0</b>	<b>2.50</b>	<b>GR7300800</b>
85.0	90.0	5.6	2.50	GR6500850
85.0	90.0	9.7	2.50	GR6900850
90.0	95.0	5.6	2.50	GR6500900
<b>90.0</b>	<b>95.0</b>	<b>9.7</b>	<b>2.50</b>	<b>GR6900900</b>
<b>90.0</b>	<b>95.0</b>	<b>15.0</b>	<b>2.50</b>	<b>GR7300900</b>
95.0	100.0	9.7	2.50	GR6900950
95.0	100.0	15.0	2.50	GR7300950
100.0	105.0	5.6	2.50	GR6501000
<b>100.0</b>	<b>105.0</b>	<b>9.7</b>	<b>2.50</b>	<b>GR6901000</b>
<b>100.0</b>	<b>105.0</b>	<b>15.0</b>	<b>2.50</b>	<b>GR7301000</b>
105.0	110.0	9.7	2.50	GR6901050
105.0	110.0	15.0	2.50	GR7301050
<b>110.0</b>	<b>115.0</b>	<b>9.7</b>	<b>2.50</b>	<b>GR6901100</b>
<b>110.0</b>	<b>115.0</b>	<b>15.0</b>	<b>2.50</b>	<b>GR7301100</b>
115.0	120.0	9.7	2.50	GR6901150
115.0	120.0	15.0	2.50	GR7301150
120.0	125.0	5.6	2.50	GR6501200
120.0	125.0	9.7	2.50	GR6901200
120.0	125.0	15.0	2.50	GR7301200
<b>125.0</b>	<b>130.0</b>	<b>9.7</b>	<b>2.50</b>	<b>GR6901250</b>
<b>125.0</b>	<b>130.0</b>	<b>15.0</b>	<b>2.50</b>	<b>GR7301250</b>
130.0	135.0	15.0	2.50	GR7301300
135.0	140.0	15.0	2.50	GR7301350
<b>140.0</b>	<b>145.0</b>	<b>9.7</b>	<b>2.50</b>	<b>GR6901400</b>
<b>140.0</b>	<b>145.0</b>	<b>15.0</b>	<b>2.50</b>	<b>GR7301400</b>
150.0	155.0	15.0	2.50	GR7301500
155.0	160.0	15.0	2.50	GR7301550
<b>160.0</b>	<b>165.0</b>	<b>9.7</b>	<b>2.50</b>	<b>GR6901600</b>
<b>160.0</b>	<b>165.0</b>	<b>15.0</b>	<b>2.50</b>	<b>GR7301600</b>
170.0	175.0	15.0	2.50	GR7301700
<b>180.0</b>	<b>185.0</b>	<b>9.7</b>	<b>2.50</b>	<b>GR6901800</b>
<b>180.0</b>	<b>185.0</b>	<b>15.0</b>	<b>2.50</b>	<b>GR7301800</b>
190.0	195.0	15.0	2.50	GR7301900
195.0	200.0	15.0	2.50	GR7301950
<b>200.0</b>	<b>205.0</b>	<b>15.0</b>	<b>2.50</b>	<b>GR7302000</b>



Dimensions				TSS Part No.
Rod Diameter	Groove Diameter	Groove Width	Thick-ness	
$d_N$ f8/h9	$D_2$ H8	$L_2$ +0.2	W	
<b>200.0</b>	<b>205.0</b>	<b>25.0</b>	<b>2.50</b>	<b>GR7502000</b>
210.0	215.0	15.0	2.50	GR7302100
<b>220.0</b>	<b>225.0</b>	<b>15.0</b>	<b>2.50</b>	<b>GR7302200</b>
<b>220.0</b>	<b>225.0</b>	<b>25.0</b>	<b>2.50</b>	<b>GR7502200</b>
230.0	235.0	25.0	2.50	GR7502300
240.0	245.0	25.0	2.50	GR7502400
<b>250.0</b>	<b>255.0</b>	<b>15.0</b>	<b>2.50</b>	<b>GR7302500</b>
<b>250.0</b>	<b>255.0</b>	<b>25.0</b>	<b>2.50</b>	<b>GR7502500</b>
<b>280.0</b>	<b>285.0</b>	<b>15.0</b>	<b>2.50</b>	<b>GR7302800</b>
<b>280.0</b>	<b>285.0</b>	<b>25.0</b>	<b>2.50</b>	<b>GR7502800</b>
<b>280.0</b>	<b>288.0</b>	<b>25.0</b>	<b>4.00</b>	<b>GR9802800</b>
300.0	305.0	25.0	2.50	GR7503000
<b>320.0</b>	<b>325.0</b>	<b>15.0</b>	<b>2.50</b>	<b>GR7303200</b>
<b>320.0</b>	<b>325.0</b>	<b>25.0</b>	<b>2.50</b>	<b>GR7503200</b>
<b>320.0</b>	<b>328.0</b>	<b>25.0</b>	<b>4.00</b>	<b>GR9803200</b>
350.0	355.0	25.0	2.50	GR7503500
<b>360.0</b>	<b>365.0</b>	<b>15.0</b>	<b>2.50</b>	<b>GR7303600</b>
<b>360.0</b>	<b>365.0</b>	<b>25.0</b>	<b>2.50</b>	<b>GR7503600</b>
<b>360.0</b>	<b>368.0</b>	<b>25.0</b>	<b>4.00</b>	<b>GR9803600</b>
400.0	405.0	25.0	2.50	GR7504000
400.0	408.0	25.0	4.00	GR9804000
800.0	805.0	25.0	2.50	GR7508000
800.0	808.0	25.0	4.00	GR9808000
1000.0	1005.0	25.0	2.50	GR75X1000
1000.0	1008.0	25.0	4.00	GR98X1000
2600.0	2605.0	25.0	2.50	GR75X2600
4200.0	4205.0	25.0	2.50	GR75X4200

Zurcon® Z80 is not available as GR98 and GR98X (Thickness W=4.0 mm)

All sizes printed in **bold** type conform to ISO 10766 and should be preferred for use.

All intermediate sizes not contained in the table are available upon request.



## ■ HiMod® Slydring® for Piston and Rod

### Description

HiMod® Slydring® are made in special, modified thermoplastic material and can be used in hydraulic cylinders for medium to high loads. Three different grades of material are available:

HiMod® HM061: A special glass fibre reinforced polyacetal

HiMod® HM062: A special glass fibre reinforced heat-stabilised polyamid with PTFE filler

HiMod® HM063: A special glass fibre reinforced heat-stabilised polyamid

Slydring® in material HM061, HM062 and HM063 are injection moulded to finish parts (mould necessary), a wide range of standard sizes (see Tables XXI and XXXIII) are available.

Old ref. description in HM061

Polypac: PO (POM/GL/BK)  
Sealing Parts: POG2 (Wearite)

### Application Examples

HiMod® Slydring® (HM061, 062, 063) is generally utilised in a wide range of hydraulic equipment such as:

- Standard hydraulic cylinder, medium range
- Truck tail lift
- Telescopic cylinders
- Truck cranes
- Forklift truck
- Stabiliser cylinders
- Agriculture equipment
- Construction machinery

### Materials

#### HiMod® HM061

HiMod® HM061 is a polyacetal (POM) based material with glass fibres.

#### Advantages:

- Favourable price/performance ratio
- High compressive strength
- Easy installation on pistons and glands (gland bore > 40 mm)
- High wear resistance
- Water absorption 0.2 %
- High stiffness.

#### Technical Data

Velocity, reciprocating: Max. 0.8 m/s  
Temperature: -40°C to +110°C

Radial Slydring® pressure Pr: Max. 40 N/mm<sup>2</sup> at 25°C  
Max. 25 N/mm<sup>2</sup> >60°C

When calculating the width of HiMod® Slydring® it is recommended to use a safety factor f=2 (see page 8).

#### Important Note:

The above stated limits for pressure and speed are maximum values individually. Friction heat generated by the combination of pressure and speed may cause local heat built-up. Care should be taken not to apply high values for pressure and speed at the same time.





## HiMod® HM062

HM062 is a polyamid (PA 66) based material with glass fibres and PTFE filler. The material is heat stabilised.

### Advantages:

- Good price/performance ratio
- High compressive strength even at high temperatures
- High wear resistance
- Easy installation on pistons and glands (gland bore > 30 mm)
- Low friction
- For operation under poor lubrication.

### Technical Data

Velocity, reciprocating:	Max. 1.0 m/s
Temperature:	-40°C to +130°C
Radial Slydring® pressure Pr:	Max. 75 N/mm <sup>2</sup> at 60°C Max. 40 N/mm <sup>2</sup> >60°C

When calculating the width of HiMod® Slydring® it is recommended to use a safety factor f=2 (see page 8).

### Important Note:

The above stated limits for pressure and speed are maximum values individually. Friction heat generated by the combination of pressure and speed may cause local heat built-up. Care should be taken not to apply high values for pressure and speed at the same time.

## HiMod® HM063

HM063 is a polyamid (PA 66) based material with glass fibres. The material is heat stabilised.

### Advantages:

- Good price/performance ratio
- High compressive strength even at high temperatures
- High wear resistance
- Easy installation on pistons and glands (gland bore > 30 mm)
- Low friction

### Technical Data

Velocity, reciprocating:	Max. 1.0 m/s
Temperature:	-40°C to +130°C
Radial Slydring® pressure Pr:	Max. 75 N/mm <sup>2</sup> at 60°C Max. 40 N/mm <sup>2</sup> >60°C

When calculating the width of HiMod® Slydring® it is recommended to use a safety factor f=2 (see page 8).



## Installation Recommendation, HiMod® Slydring® for Piston According to ISO 10766 Groove Dimension

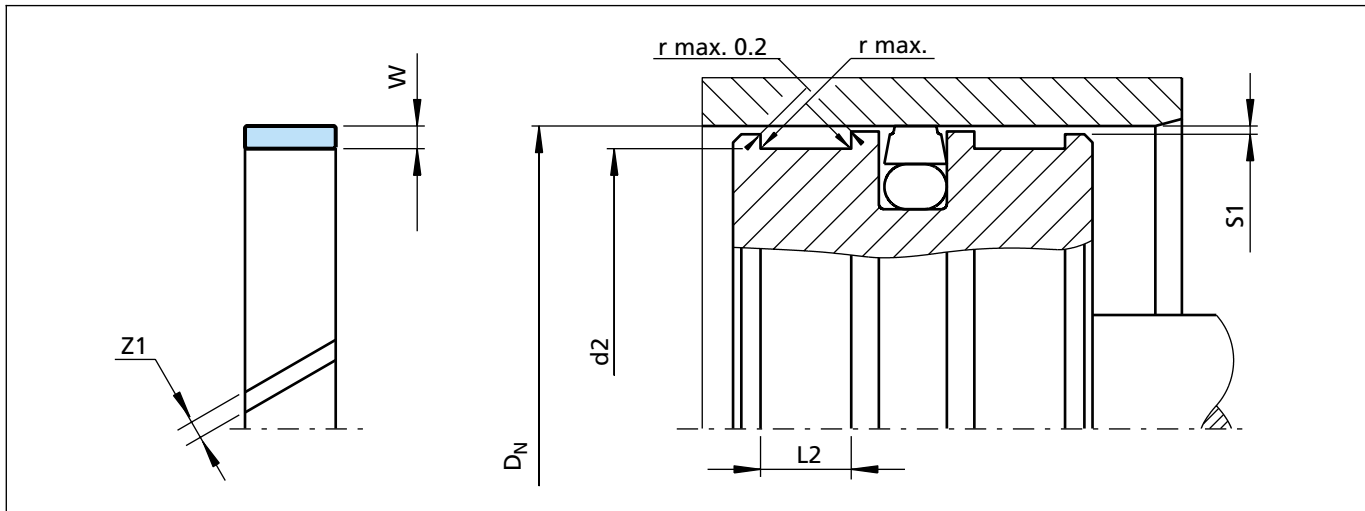

Figure 11 Installation drawing

Table XVI Installation Dimensions

Serial No.	Bore Diameter <sup>1)</sup>	Groove Diameter	Groove Width	Ring Thickness
	$D_N$ H9	$d_2$ h8	$L_2$ +0.2	$W$
GP43	10 - 50.0	$D_N$ -3.10	4.00	1.55
GP65	16 - 140.0	$D_N$ -5.00	5.60	2.50
GP69	60 - 220.0	$D_N$ -5.00	9.70	2.50
GP73	130 - 300.0	$D_N$ -5.00	15.00	2.50
GP75	280 - 300.0	$D_N$ -5.00	25.00	2.50
GP98	280 - 300.0	$D_N$ -8.00	25.00	4.00

<sup>1)</sup> Recommended diameter ranges.

For Slydring® to other standards, e.g French standard NF E 48-037, please contact us.

Table XVII Recommended Radii for Groove Dia.

$D_N$	$r$ max.
8 - 250	0.2
>250	0.4

Table XVIII Radial Clearance  $S_1$ <sup>2)</sup>

Bore Dia. $D_N$	$S_1$ min.	$S_1$ max.
8 - 20	0.20	0.30
20 - 100	0.25	0.40
101 - 250	0.30	0.60
251 - 300	0.40	0.80

<sup>2)</sup> Specifications valid only in the area of the Slydring®, but not for the seal area.



**Table XIX Recommended Gap**

D <sub>N</sub>	Ring Gap Z1
10 - 44	2 - 2.5
45 - 149	2 - 3
>150	3 - 4

**Table XX Surface Roughness**

Parameter	Mating Surface μm	Groove Surface μm
	HiMod® Materials	
R <sub>max</sub>	1.00 - 4.00	< 16.0
R <sub>z</sub> DIN	0.63 - 2.50	< 10.0
R <sub>a</sub>	0.10 - 0.40	< 2.5

**Ordering Example**

Slydring® for bore diameter D<sub>N</sub> = 100.0 mm  
 Series GP69 from Table XVI  
 Groove width: 9.70 mm, ring thickness: 2.50 mm

Material: HiMod® HM061  
 (other materials see Table I)

Standard design: With angle cut  
 Design code: 0

TSS Article No.: GP6901000-HM061 (from Table XXI)

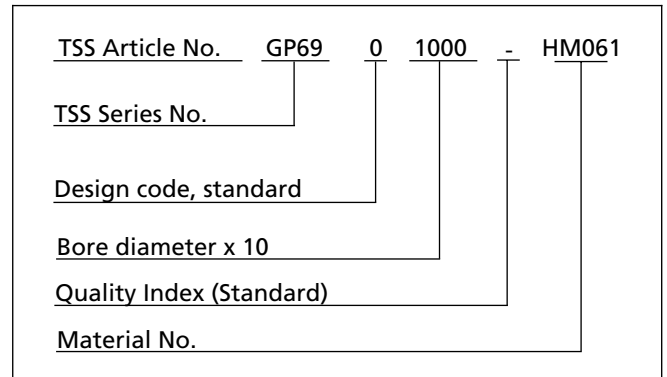

**Note**

HM062 and HM063 materials can be ordered by replacing the HM061 material code in the TSS Article Number.

Please check with your local TSS entity the availability and price of the HM062 or HM063. These materials may require new moulds.

**Table XXI Slydring® for Piston in HM061**

Dimensions				TSS Article No.	Polypac Ref. No.
Bore Diameter	Groove Diameter	Groove Width	Thickness		
D <sub>N</sub> H9	d <sub>2</sub> h8	L <sub>2</sub> +0.2	W		
12.0	8.9	4.0	1.55	GP4300120-HM061	WR 8.9 12 4
<b>16.0</b>	<b>12.9</b>	<b>4.0</b>	<b>1.55</b>	<b>GP4300160-HM061</b>	<b>WR 12.9 16 4</b>
<b>20.0</b>	<b>16.9</b>	<b>4.0</b>	<b>1.55</b>	<b>GP4300200-HM061</b>	<b>WR 16.9 20 4</b>
24.0	20.9	4.0	1.55	GP4300240-HM061	WR 20.9 24 4
<b>25.0</b>	<b>21.9</b>	<b>4.0</b>	<b>1.55</b>	<b>GP4300250-HM061</b>	<b>WR 21.9 25 4</b>
<b>25.0</b>	<b>20.0</b>	<b>5.6</b>	<b>2.50</b>	<b>GP6500250-HM061</b>	<b>WR 20 25 5.6</b>
25.0	20.0	9.7	2.50	GP6900250-HM061	WR 20 25 9.7
27.0	22.0	5.6	2.50	GP6500270-HM061	WR 22 27 5.6
27.0	22.0	9.7	2.50	GP6900270-HM061	WR 22 27 9.7
30.0	25.0	5.6	2.50	GP6500300-HM061	WR 25 30 5.6
30.0	25.0	9.7	2.50	GP6900300-HM061	WR 25 30 9.7
<b>32.0</b>	<b>28.9</b>	<b>4.0</b>	<b>1.55</b>	<b>GP4300320-HM061</b>	<b>WR 28.9 32 4</b>

All sizes printed in **bold** type conform to ISO 10766 and should be preferred for use.



# HiMod® Slydring® - Wear Ring

Dimensions				TSS Article No.	Polypac Ref. No.
Bore Diameter	Groove Diameter	Groove Width	Thickness		
<b>D<sub>N</sub></b> H9	<b>d<sub>2</sub></b> h8	<b>L<sub>2</sub></b> +0.2	<b>W</b>		
<b>32.0</b>	<b>27.0</b>	<b>5.6</b>	<b>2.50</b>	<b>GP6500320-HM061</b>	<b>WR 27 32 5.6</b>
32.0	27.0	9.7	2.50	GP6900320-HM061	WR 27 32 9.7
33.0	28.0	5.6	2.50	GP6500330-HM061	WR 28 33 5.6
35.0	30.0	5.6	2.50	GP6500350-HM061	WR 30 35 5.6
35.0	30.0	9.7	2.50	GP6900350-HM061	WR 30 35 9.7
37.0	32.0	5.6	2.50	GP6500370-HM061	WR 32 37 5.6
37.0	32.0	9.7	2.50	GP6900370-HM061	WR 32 37 9.7
<b>40.0</b>	<b>35.0</b>	<b>5.6</b>	<b>2.50</b>	<b>GP6500400-HM061</b>	<b>WR 35 40 5.6</b>
40.0	35.0	9.7	2.50	GP6900400-HM061	WR 35 40 9.7
41.0	36.0	5.6	2.50	GP6500410-HM061	WR 36 41 5.6
41.0	36.0	9.7	2.50	GP6900410-HM061	WR 36 41 9.7
45.0	40.0	5.6	2.50	GP6500450-HM061	WR 40 45 5.6
45.0	40.0	9.7	2.50	GP6900450-HM061	WR 40 45 9.7
45.0	40.0	15.0	2.50	GP7300450-HM061	WR 40 45 15
<b>50.0</b>	<b>45.0</b>	<b>5.6</b>	<b>2.50</b>	<b>GP6500500-HM061</b>	<b>WR 45 50 5.6</b>
50.0	45.0	9.7	2.50	GP6900500-HM061	WR 45 50 9.7
50.0	45.0	15.0	2.50	GP7300500-HM061	WR 45 50 15
52.0	47.0	5.6	2.50	GP6500520-HM061	WR 47 52 5.6
55.0	50.0	5.6	2.50	GP6500550-HM061	WR 50 55 5.6
55.0	50.0	9.7	2.50	GP6900550-HM061	WR 50 55 9.7
55.0	50.0	15.0	2.50	GP7300550-HM061	WR 50 55 15
57.0	52.0	5.6	2.50	GP6500570-HM061	WR 52 57 5.6
57.0	52.0	9.7	2.50	GP6900570-HM061	WR 52 57 9.7
58.0	53.0	9.7	2.50	GP6900580-HM061	WR 53 58 9.7
60.0	55.0	5.6	2.50	GP6500600-HM061	WR 55 60 5.6
60.0	55.0	9.7	2.50	GP6900600-HM061	WR 55 60 9.7
61.0	56.0	5.6	2.50	GP6500610-HM061	WR 56 61 5.6
62.0	56.0	9.7	2.50	GP6900610-HM061	WR 56 61 9.7
<b>63.0</b>	<b>58.0</b>	<b>5.6</b>	<b>2.50</b>	<b>GP6500630-HM061</b>	<b>WR 58 63 5.6</b>
<b>63.0</b>	<b>58.0</b>	<b>9.7</b>	<b>2.50</b>	<b>GP6900630-HM061</b>	<b>WR 58 63 9.7</b>
65.0	60.0	5.6	2.50	GP6500650-HM061	WR 60 65 5.6
65.0	60.0	9.7	2.50	GP6900650-HM061	WR 60 65 9.7
68.0	63.0	5.6	2.50	GP6500680-HM061	WR 63 68 5.6
68.0	63.0	9.7	2.50	GP6900680-HM061	WR 63 68 9.7
68.0	63.0	15.0	2.50	GP7300680-HM061	WR 63 68 15
70.0	65.0	5.6	2.50	GP6500700-HM061	WR 65 70 5.6

All sizes printed in **bold** type conform to ISO 10766 and should be preferred for use.



Dimensions				TSS Article No.	Polypac Ref. No.
Bore Diameter	Groove Diameter	Groove Width	Thickness		
<b>D<sub>N</sub></b> H9	<b>d<sub>2</sub></b> h8	<b>L<sub>2</sub></b> +0.2	<b>W</b>		
70.0	65.0	9.7	2.50	GP6900700-HM061	WR 65 70 9.7
72.0	67.0	5.6	2.50	GP6500720-HM061	WR 67 72 5.6
75.0	70.0	5.6	2.50	GP6500750-HM061	WR 70 75 5.6
75.0	70.0	9.7	2.50	GP6900750-HM061	WR 70 75 9.7
75.0	70.0	15.0	2.50	GP7300750-HM061	WR 70 75 15
<b>80.0</b>	<b>75.0</b>	<b>5.6</b>	<b>2.50</b>	<b>GP6500800-HM061</b>	<b>WR 75 80 5.6</b>
<b>80.0</b>	<b>75.0</b>	<b>9.7</b>	<b>2.50</b>	<b>GP6900800-HM061</b>	<b>WR 75 80 9.7</b>
<b>80.0</b>	<b>75.0</b>	<b>15.0</b>	<b>2.50</b>	<b>GP7300800-HM061</b>	<b>WR 75 80 15</b>
85.0	80.0	5.6	2.50	GP6500850-HM061	WR 80 85 5.6
85.0	80.0	9.7	2.50	GP6900850-HM061	WR 80 85 9.7
85.0	80.0	15.0	2.50	GP7300850-HM061	WR 80 85 15
90.0	85.0	5.6	2.50	GP6500900-HM061	WR 85 90 5.6
90.0	85.0	9.7	2.50	GP6900900-HM061	WR 85 90 9.7
90.0	85.0	15.0	2.50	GP7300900-HM061	WR 85 90 15
95.0	90.0	5.6	2.50	GP6500950-HM061	WR 90 95 5.6
95.0	90.0	9.7	2.50	GP6900950-HM061	WR 90 95 9.7
<b>100.0</b>	<b>95.0</b>	<b>5.6</b>	<b>2.50</b>	<b>GP6501000-HM061</b>	<b>WR 95 100 5.6</b>
<b>100.0</b>	<b>95.0</b>	<b>9.7</b>	<b>2.50</b>	<b>GP6901000-HM061</b>	<b>WR 95 100 9.7</b>
<b>100.0</b>	<b>95.0</b>	<b>15.0</b>	<b>2.50</b>	<b>GP7301000-HM061</b>	<b>WR 95 100 15</b>
105.0	100.0	5.6	2.50	GP6501050-HM061	WR 100 105 5.6
105.0	100.0	9.7	2.50	GP6901050-HM061	WR 100 105 9.7
105.0	100.0	15.0	2.50	GP7301050-HM061	WR 100 105 15
110.0	105.0	9.7	2.50	GP6901100-HM061	WR 105 110 9.7
110.0	105.0	15.0	2.50	GP7301100-HM061	WR 105 110 15
115.0	110.0	9.7	2.50	GP6901150-HM061	WR 110 115 9.7
115.0	110.0	15.0	2.50	GP7301150-HM061	WR 110 115 15
120.0	115.0	9.7	2.50	GP6901200-HM061	WR 115 120 9.7
<b>125.0</b>	<b>120.0</b>	<b>5.6</b>	<b>2.50</b>	<b>GP6501250-HM061</b>	<b>WR 120 125 5.6</b>
<b>125.0</b>	<b>120.0</b>	<b>9.7</b>	<b>2.50</b>	<b>GP6901250-HM061</b>	<b>WR 120 125 9.7</b>
<b>125.0</b>	<b>120.0</b>	<b>15.0</b>	<b>2.50</b>	<b>GP7301250-HM061</b>	<b>WR 120 125 15</b>
130.0	125.0	15.0	2.50	GP7301300-HM061	WR 125 130 15
<b>140.0</b>	<b>135.0</b>	<b>9.7</b>	<b>2.50</b>	<b>GP6901400-HM061</b>	<b>WR 135 140 9.7</b>
<b>140.0</b>	<b>135.0</b>	<b>15.0</b>	<b>2.50</b>	<b>GP7301400-HM061</b>	<b>WR 135 140 15</b>
<b>160.0</b>	<b>155.0</b>	<b>9.7</b>	<b>2.50</b>	<b>GP6901600-HM061</b>	<b>WR 155 160 9.7</b>
<b>160.0</b>	<b>155.0</b>	<b>15.0</b>	<b>2.50</b>	<b>GP7301600-HM061</b>	<b>WR 155 160 15</b>
<b>200.0</b>	<b>195.0</b>	<b>15.0</b>	<b>2.50</b>	<b>GP7302000-HM061</b>	<b>WR 195 200 15</b>

All sizes printed in **bold** type conform to ISO 10766 and should be preferred for use.



## Installation Recommendation, HiMod® Slydring® for Piston Non ISO 10766 Groove Dimension

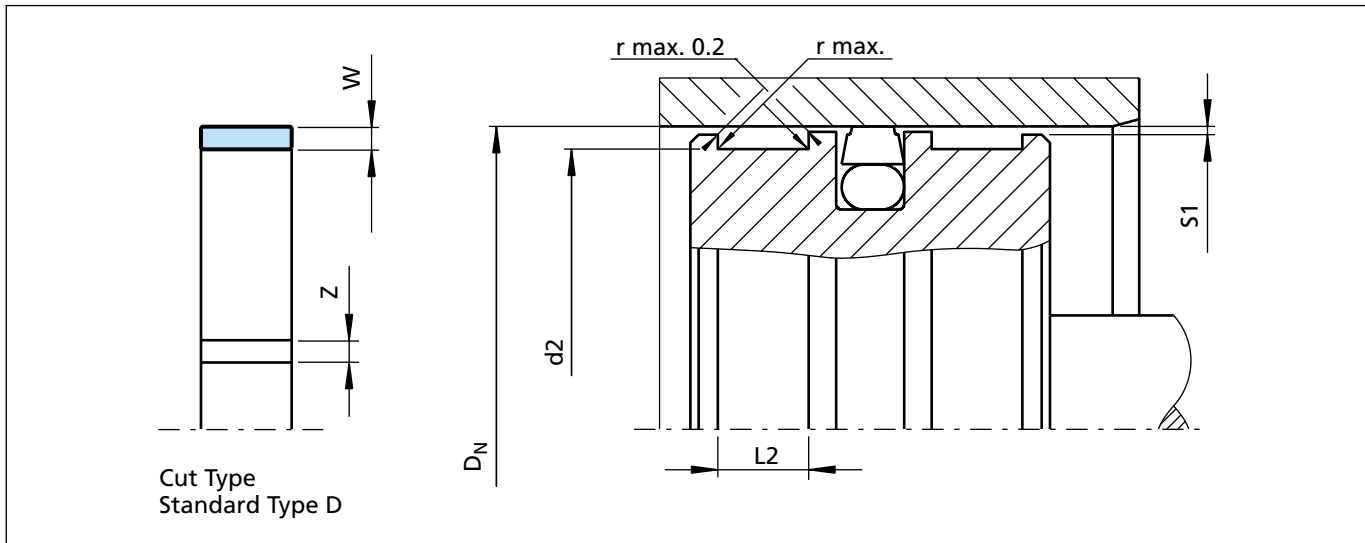

Figure 12 Installation drawing

**Table XXII Installation Dimensions HiMod® Slydring® for Piston non ISO 10766 Groove Dimensions**

Serial No.	Groove Diameter	Groove Width	Ring Thickness
	$d_2 \text{ h}8$	$L_2 +0.2$	$W$
GP49	$D_N -4.00$	9.70	2.00
GP51	$D_N -4.00$	10.00	2.00
GP53	$D_N -4.00$	15.00	2.00
GP54	$D_N -4.00$	20.00	2.00
GP67	$D_N -5.00$	6.30	2.50
GP68	$D_N -5.00$	8.10	2.50
GP71	$D_N -5.00$	10.00	2.50
GPN1	$D_N -6.00$	9.70	3.00

Serial No.	Groove Diameter	Groove Width	Ring Thickness
	$d_2 \text{ h}8$	$L_2 +0.2$	$W$
GP91	$D_N -6.00$	10.00	3.00
GP92	$D_N -6.00$	12.00	3.00
GPN3	$D_N -6.00$	12.80	3.00
GP93	$D_N -6.00$	15.00	3.00
GPN4	$D_N -6.00$	19.20	3.00
GP94	$D_N -6.00$	20.00	3.00
GP95	$D_N -6.00$	25.00	3.00
GPL2	$D_N -8.00$	15.00	4.00

**Table XXIII Recommended Radii for Groove Dia.**

$d_N$	$r \text{ max.}$
8 - 250	0.2
>250	0.4

**Table XXIV Radial Clearance  $S1^{2)}$**

Bore Dia. $D_N$	$S1 \text{ min.}$	$S1 \text{ max.}$
8 - 20	0.20	0.30
20 - 100	0.25	0.40
101 - 250	0.30	0.60
251 - 300	0.40	0.80

<sup>2)</sup> Specifications valid only in the area of the Slydring®, but not for the seal area.



**Table XXV Recommended Gap**

$D_N$	Ring Gap Z
16 - 49	1 - 1.5
50 - 154	1.5 - 2.5
>155	2 - 4

**Table XXVI Surface Roughness**

Parameter	Mating Surface $\mu\text{m}$	Groove Surface $\mu\text{m}$
	HiMod® Materials	
$R_{\text{max}}$	1.00 - 4.00	< 16.0
$R_{z \text{ DIN}}$	0.63 - 2.50	< 10.0
$R_a$	0.10 - 0.40	< 2.5

## Ordering Example

For Polypac Slydring® Ref. No. E/DWR 20/2  
 Bore diameter  $D_N = 20.0 \text{ mm}$   
 Groove width: 9.70 mm, ring thickness: 2.00 mm

Material: HM061

Standard design: With straight cut  
 Design code: D

## Note

HM062 and HM063 materials can be ordered by replacing the HM061 material code in the TSS Article Number.

Please check with your local TSS entity the availability and price of the HM062 or HM063. These materials may require new moulds.

TSS Article No.	GP49	D	0200	-	HM061
TSS Series No.					
Design code, standard					
Bore diameter x 10					
Quality Index (Standard)					
Material No.					

**Table XXVII Slydring® for Piston in HM061**

Dimensions				TSS Article No.	Polypac Ref. No.
Bore Diameter	Groove Diameter	Groove Width	Thickness		
$D_N \text{ H11}$	$d_2 \text{ h9}$	$L_2 +0.2$	$W$		
16.0	12.0	9.7	2.00	GP49D0160-HM061	E/DWR 16/2-9.6
18.0	14.0	9.7	2.00	GP49D0180-HM061	E/DWR 18/2-9.6
20.0	16.0	9.7	2.00	GP49D0200-HM061	E/DWR 20/2-9.6
22.0	18.0	9.7	2.00	GP49D0220-HM061	E/DWR 22/2-9.6
24.0	20.0	9.7	2.00	GP49D0240-HM061	E/DWR 24/2-9.6
25.0	21.0	9.7	2.00	GP49D0250-HM061	E/DWR 25/2-9.6
26.0	22.0	9.7	2.00	GP49D0260-HM061	E/DWR 26/2-9.6
27.0	23.0	9.7	2.00	GP49D0270-HM061	E/DWR 27/2-9.6
28.0	24.0	9.7	2.00	GP49D0280-HM061	E/DWR 28/2-9.6
29.0	25.0	9.7	2.00	GP49D0290-HM061	E/DWR 29/2-9.6
30.0	26.0	9.7	2.00	GP49D0300-HM061	E/DWR 30/2-9.6
32.0	28.0	9.7	2.00	GP49D0320-HM061	E/DWR 32/2-9.6
33.0	29.0	9.7	2.00	GP49D0330-HM061	E/DWR 33/2-9.6
34.0	30.0	9.7	2.00	GP49D0340-HM061	E/DWR 34/2-9.6
35.0	31.0	9.7	2.00	GP49D0350-HM061	E/DWR 35/2-9.6



# HiMod® Slydring® - Wear Ring

Dimensions				TSS Article No.	Polypac Ref. No.
Bore Diameter	Groove Diameter	Groove Width	Thickness		
D <sub>N</sub> H11	d <sub>2</sub> h9	L <sub>2</sub> +0.2	W		
35.0	29.0	9.7	3.00	GPN1D0350-HM061	E/DWR 35/3-9.6
36.0	32.0	9.7	2.00	GP49D0360-HM061	E/DWR 36/2-9.6
38.0	34.0	9.7	2.00	GP49D0380-HM061	E/DWR 38/2-9.6
39.0	35.0	9.7	2.00	GP49D0390-HM061	E/DWR 39/2-9.6
39.0	35.0	12.8	2.00	GPN3D0390-HM061	E/DWR 39/2-12.8
39.0	33.0	9.7	3.00	GPN1D0390-HM061	E/DWR 39/3-9.6
40.0	36.0	9.7	2.00	GP49D0400-HM061	E/DWR 40/2-9.6
40.0	34.0	9.7	3.00	GPN1D0400-HM061	E/DWR 40/3-9.6
42.0	38.0	9.7	2.00	GP49D0420-HM061	E/DWR 42/2-9.6
44.0	40.0	9.7	2.00	GP49D0440-HM061	E/DWR 44/2-9.6
44.0	38.0	9.7	3.00	GPN1D0440-HM061	E/DWR 44/3-9.6
45.0	41.0	9.7	2.00	GP49D0450-HM061	E/DWR 45/2-9.6
45.0	39.0	9.7	3.00	GPN1D0450-HM061	E/DWR 45/3-9.6
46.0	40.0	9.7	3.00	GPN1D0460-HM061	E/DWR 46/3-9.6
48.0	42.0	9.7	3.00	GPN1D0480-HM061	E/DWR 48/3-9.6
48.0	42.0	12.8	3.00	GPN3D0480-HM061	E/DWR 48/3-12.8
49.0	45.0	9.7	2.00	GP49D0490-HM061	E/DWR 49/2-9.6
49.0	43.0	9.7	3.00	GPN1D0490-HM061	E/DWR 49/3-9.6
50.0	44.0	9.7	3.00	GPN1D0500-HM061	E/DWR 50/3-9.6
50.0	44.0	12.8	3.00	GPN3D0500-HM061	E/DWR 50/3-12.8
52.0	46.0	12.8	3.00	GPN3D0520-HM061	E/DWR 52/3-12.8
53.0	47.0	9.7	3.00	GPN1D0530-HM061	E/DWR 53/3-9.6
54.0	48.0	12.8	3.00	GPN3D0540-HM061	E/DWR 54/3-12.8
55.0	51.0	9.7	2.00	GP49D0550-HM061	E/DWR 55/2-9.6
55.0	49.0	9.7	3.00	GPN1D0550-HM061	E/DWR 55/3-9.6
55.0	49.0	12.8	3.00	GPN3D0550-HM061	E/DWR 55/3-12.8
56.0	50.0	12.8	3.00	GPN3D0560-HM061	E/DWR 56/3-12.8
57.0	51.0	12.8	3.00	GPN3D0570-HM061	E/DWR 57/3-12.8
59.0	55.0	9.7	2.00	GP49D0590-HM061	E/DWR 59/2-9.6
60.0	56.0	9.7	2.00	GP49D0600-HM061	E/DWR 60/2-9.6
60.0	54.0	12.8	3.00	GPN3D0600-HM061	E/DWR 60/3-12.8
62.0	56.0	12.8	3.00	GPN3D0620-HM061	E/DWR 62/3-12.8
63.0	57.0	12.8	3.00	GPN3D0630-HM061	E/DWR 63/3-12.8
65.0	61.0	9.7	2.00	GP49D0650-HM061	E/DWR 65/2-9.6
65.0	59.0	12.8	3.00	GPN3D0650-HM061	E/DWR 65/3-12.8
67.0	61.0	12.8	3.00	GPN3D0670-HM061	E/DWR 67/3-12.8







Dimensions				TSS Article No.	Polypac Ref. No.
Bore Diameter	Groove Diameter	Groove Width	Thickness		
$D_N$ H11	$d_2$ h9	$L_2$ +0.2	$W$		
68.0	62.0	12.8	3.00	GPN3D0680-HM061	E/DWR 68/3-12.8
70.0	64.0	12.8	3.00	GPN3D0700-HM061	E/DWR 70/3-12.8
71.0	65.0	12.8	3.00	GPN3D0710-HM061	E/DWR 71/3-12.8
72.0	66.0	12.8	3.00	GPN3D0720-HM061	E/DWR 72/3-12.8
74.0	70.0	9.7	2.00	GP49D0740-HM061	E/DWR 74/2-9.6
74.0	68.0	12.8	3.00	GPN3D0740-HM061	E/DWR 74/3-12.8
75.0	69.0	12.8	3.00	GPN3D0750-HM061	E/DWR 75/3-12.8
76.0	70.0	12.8	3.00	GPN3D0760-HM061	E/DWR 76/3-12.8
77.0	71.0	12.8	3.00	GPN3D0770-HM061	E/DWR 77/3-12.8
80.0	74.0	12.8	3.00	GPN3D0800-HM061	E/DWR 80/3-12.8
83.0	77.0	12.8	3.00	GPN3D0830-HM061	E/DWR 83/3-12.8
84.0	78.0	12.8	3.00	GPN3D0840-HM061	E/DWR 84/3-12.8
85.0	79.0	12.8	3.00	GPN3D0850-HM061	E/DWR 85/3-12.8
88.0	82.0	12.8	3.00	GPN3D0880-HM061	E/DWR 88/3-12.8
89.0	83.0	12.8	3.00	GPN3D0890-HM061	E/DWR 89/3-12.8
90.0	84.0	12.8	3.00	GPN3D0900-HM061	E/DWR 90/3-12.8
91.0	85.0	12.8	3.00	GPN3D0910-HM061	E/DWR 91/3-12.8
92.0	86.0	12.8	3.00	GPN3D0920-HM061	E/DWR 92/3-12.8
93.0	87.0	12.8	3.00	GPN3D0930-HM061	E/DWR 93/3-12.8
94.0	88.0	12.8	3.00	GPN3D0940-HM061	E/DWR 94/3-12.8
95.0	89.0	12.8	3.00	GPN3D0950-HM061	E/DWR 95/3-12.8
100.0	94.0	9.7	3.00	GPN1D1000-HM061	E/DWR 100/3-9.6
100.0	94.0	12.8	3.00	GPN3D1000-HM061	E/DWR 100/3-12.8
102.0	96.0	12.8	3.00	GPN3D1020-HM061	E/DWR 102/3-12.8
104.0	98.0	12.8	3.00	GPN3D1040-HM061	E/DWR 104/3-12.8
105.0	99.0	12.8	3.00	GPN3D1050-HM061	E/DWR 105/3-12.8
105.0	99.0	19.2	3.00	GPN4D1050-HM061	E/DWR 105/3-19.2
108.0	102.0	12.8	3.00	GPN3D1080-HM061	E/DWR 108/3-12.8
110.0	104.0	12.8	3.00	GPN3D1100-HM061	E/DWR 110/3-12.8
112.0	106.0	19.2	3.00	GPN4D1120-HM061	E/DWR 112/3-19.2
115.0	109.0	12.8	3.00	GPN3D1150-HM061	E/DWR 115/3-12.8
115.0	109.0	19.2	3.00	GPN4D1150-HM061	E/DWR 115/3-19.2
116.0	110.0	12.8	3.00	GPN3D1160-HM061	E/DWR 116/3-12.8
116.0	110.0	19.2	3.00	GPN4D1160-HM061	E/DWR 116/3-19.2
118.0	112.0	12.8	3.00	GPN3D1180-HM061	E/DWR 118/3-12.8
120.0	114.0	12.8	3.00	GPN3D1200-HM061	E/DWR 120/3-12.8



# HiMod® Slydring® - Wear Ring

Dimensions				TSS Article No.	Polypac Ref. No.
Bore Diameter	Groove Diameter	Groove Width	Thickness		
D <sub>N</sub> H11	d <sub>2</sub> h9	L <sub>2</sub> +0.2	W		
121.0	115.0	12.8	3.00	GPN3D1210-HM061	E/DWR 121/3-12.8
123.0	117.0	12.8	3.00	GPN3D1230-HM061	E/DWR 123/3-12.8
125.0	119.0	12.8	3.00	GPN3D1250-HM061	E/DWR 125/3-12.8
125.0	119.0	19.2	3.00	GPN4D1250-HM061	E/DWR 125/3-19.2
126.0	120.0	12.8	3.00	GPN3D1260-HM061	E/DWR 126/3-12.8
127.0	121.0	12.8	3.00	GPN3D1270-HM061	E/DWR 127/3-12.8
130.0	124.0	12.8	3.00	GPN3D1300-HM061	E/DWR 130/3-12.8
130.0	124.0	19.2	3.00	GPN4D1300-HM061	E/DWR 130/3-19.2
133.0	127.0	12.8	3.00	GPN3D1330-HM061	E/DWR 133/3-12.8
135.0	129.0	12.8	3.00	GPN3D1350-HM061	E/DWR 135/3-12.8
135.0	129.0	19.2	3.00	GPN4D1350-HM061	E/DWR 135/3-19.2
140.0	134.0	12.8	3.00	GPN3D1400-HM061	E/DWR 140/3-12.8
140.0	134.0	19.2	3.00	GPN4D1400-HM061	E/DWR 140/3-19.2
145.0	139.0	12.8	3.00	GPN3D1450-HM061	E/DWR 145/3-12.8
145.0	139.0	19.2	3.00	GPN4D1450-HM061	E/DWR 145/3-19.2
146.0	140.0	12.8	3.00	GPN3D1460-HM061	E/DWR 146/3-12.8
147.0	141.0	12.8	3.00	GPN3D1470-HM061	E/DWR 147/3-12.8
150.0	144.0	12.8	3.00	GPN3D1500-HM061	E/DWR 150/3-12.8
150.0	144.0	19.2	3.00	GPN4D1500-HM061	E/DWR 150/3-19.2
151.0	145.0	12.8	3.00	GPN3D1510-HM061	E/DWR 151/3-12.8
152.0	146.0	19.2	3.00	GPN4D1520-HM061	E/DWR 152/3-19.2
153.0	147.0	19.2	3.00	GPN4D1530-HM061	E/DWR 153/3-19.2
154.0	148.0	19.2	3.00	GPN4D1540-HM061	E/DWR 154/3-19.2
155.0	149.0	19.2	3.00	GPN4D1550-HM061	E/DWR 155/3-19.2
158.0	152.0	19.2	3.00	GPN4D1580-HM061	E/DWR 158/3-19.2
160.0	154.0	19.2	3.00	GPN4D1600-HM061	E/DWR 160/3-19.2
165.0	159.0	19.2	3.00	GPN4D1650-HM061	E/DWR 165/3-19.2
168.0	162.0	12.8	3.00	GPN3D1680-HM061	E/DWR 168/3-12.8
168.0	162.0	19.2	3.00	GPN4D1680-HM061	E/DWR 168/3-19.2
170.0	164.0	19.2	3.00	GPN4D1700-HM061	E/DWR 170/3-19.2
172.0	166.0	19.2	3.00	GPN4D1720-HM061	E/DWR 172/3-19.2
175.0	169.0	19.2	3.00	GPN4D1750-HM061	E/DWR 175/3-19.2
180.0	174.0	19.2	3.00	GPN4D1800-HM061	E/DWR 180/3-19.2
181.0	175.0	19.2	3.00	GPN4D1810-HM061	E/DWR 181/3-19.2
185.0	179.0	19.2	3.00	GPN4D1850-HM061	E/DWR 185/3-19.2
189.0	183.0	19.2	3.00	GPN4D1890-HM061	E/DWR 189/3-19.2





Dimensions				TSS Article No.	Polypac Ref. No.
Bore Diameter	Groove Diameter	Groove Width	Thickness		
$D_N$ H11	$d_2$ h9	$L_2$ +0.2	$W$		
190.0	184.0	19.2	3.00	GPN4D1900-HM061	E/DWR 190/3-19.2
192.0	186.0	19.2	3.00	GPN4D1920-HM061	E/DWR 192/3-19.2
195.0	189.0	19.2	3.00	GPN4D1950-HM061	E/DWR 195/3-19.2
200.0	194.0	19.2	3.00	GPN4D2000-HM061	E/DWR 200/3-19.2
205.0	199.0	19.2	3.00	GPN4D2050-HM061	E/DWR 205/3-19.2
210.0	204.0	19.2	3.00	GPN4D2100-HM061	E/DWR 210/3-19.2
215.0	209.0	19.2	3.00	GPN4D2150-HM061	E/DWR 215/3-19.2
217.0	211.0	19.2	3.00	GPN4D2170-HM061	E/DWR 217/3-19.2
220.0	214.0	19.2	3.00	GPN4D2200-HM061	E/DWR 220/3-19.2
225.0	219.0	19.2	3.00	GPN4D2250-HM061	E/DWR 225/3-19.2
230.0	224.0	19.2	3.00	GPN4D2300-HM061	E/DWR 230/3-19.2
235.0	229.0	19.2	3.00	GPN4D2350-HM061	E/DWR 235/3-19.2
237.0	231.0	19.2	3.00	GPN4D2370-HM061	E/DWR 237/3-19.2
240.0	234.0	19.2	3.00	GPN4D2400-HM061	E/DWR 240/3-19.2
245.0	239.0	19.2	3.00	GPN4D2450-HM061	E/DWR 245/3-19.2
250.0	244.0	19.2	3.00	GPN4D2500-HM061	E/DWR 250/3-19.2
254.0	248.0	19.2	3.00	GPN4D2540-HM061	E/DWR 254/3-19.2
255.0	249.0	19.2	3.00	GPN4D2550-HM061	E/DWR 255/3-19.2
260.0	254.0	19.2	3.00	GPN4D2600-HM061	E/DWR 260/3-19.2
265.0	259.0	19.2	3.00	GPN4D2650-HM061	E/DWR 265/3-19.2
270.0	264.0	19.2	3.00	GPN4D2700-HM061	E/DWR 270/3-19.2
275.0	269.0	19.2	3.00	GPN4D2750-HM061	E/DWR 275/3-19.2
280.0	274.0	19.2	3.00	GPN4D2800-HM061	E/DWR 280/3-19.2
285.0	279.0	19.2	3.00	GPN4D2850-HM061	E/DWR 285/3-19.2
290.0	284.0	19.2	3.00	GPN4D2900-HM061	E/DWR 290/3-19.2
295.0	289.0	19.2	3.00	GPN4D2950-HM061	E/DWR 295/3-19.2
300.0	294.0	19.2	3.00	GPN4D3000-HM061	E/DWR 300/3-19.2



## ■ Installation Recommendation, HiMod® Slydring® for Rod According to ISO 10766 Groove Dimension

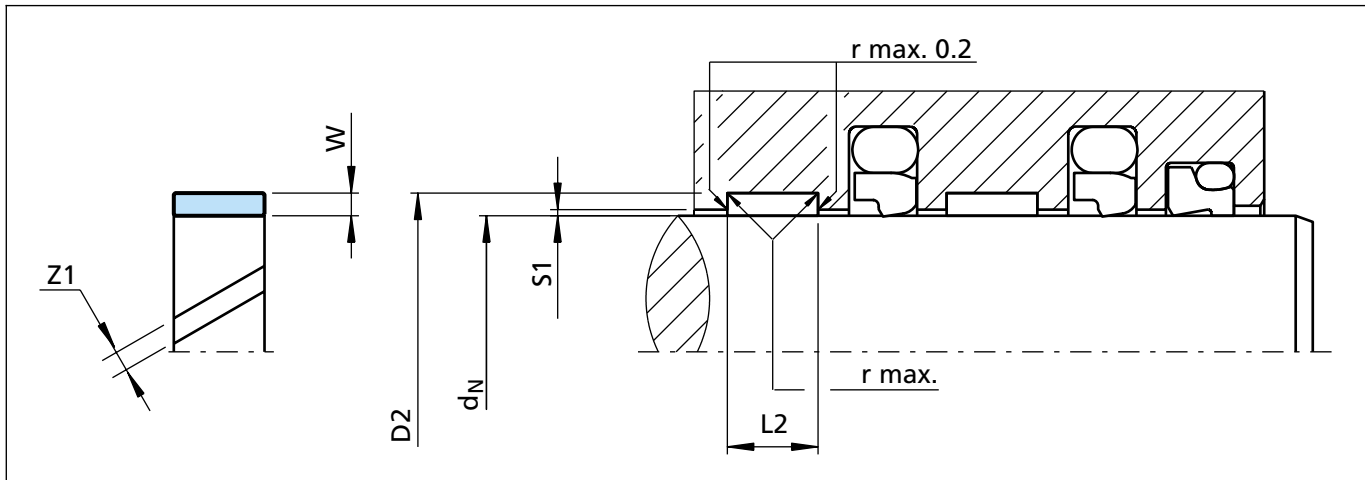

Figure 13 Installation drawing

**Table XXVIII Installation Dimensions**

Series No.	Rod Diameter <sup>1)</sup>	Groove Diameter	Groove Width	Ring Thickness
	$d_N$ f8/h9	$D_2$ H8	$L_2$ +0.2	$W$
GR43	10 - 50.0	$d_N$ +3.10	4.00	1.55
GR65	15 - 140.0	$d_N$ +5.00	5.60	2.50
GR69	20 - 220.0	$d_N$ +5.00	9.70	2.50
GR73	80 - 300.0	$d_N$ +5.00	15.00	2.50
GR75	200 - 300.0	$d_N$ +5.00	25.00	2.50
GR98	280 - 300.0	$d_N$ +8.00	25.00	4.00

<sup>1)</sup> Recommended diameter ranges

For Slydring® to other standards, e.g French standard NF E 48-037, please contact us.

**Table XXIX Recommended Radii for Groove Dia.**

$D_N$	$r$ max.
8 - 250	0.2
>250	0.4

**Table XXX Radial Clearance  $S_1$  <sup>2)</sup>**

Rod Dia. $d_N$	$S_1$ min.	$S_1$ max.
8 - 20	0.20	0.30
20 - 100	0.25	0.40
101 - 250	0.30	0.60
251 - 300	0.40	0.80

<sup>2)</sup> Specifications valid only in the area of the Slydring®, but not for the seal area.



**Table XXXI Recommended Gap**

$D_N$	Ring Gap Z1
10 - 39	2 - 2.5
40 - 149	2 - 3
>150	3 - 4

**Table XXXII Surface Roughness**

Parameter	Mating Surface $\mu\text{m}$	Groove Surface $\mu\text{m}$
	HiMod® Materials	
$R_{\text{max}}$	1.00 - 4.00	< 16.0
$R_{z \text{ DIN}}$	0.63 - 2.50	< 10.0
$R_a$	0.10 - 0.40	< 2.5

**Ordering Example**

Slydring® for rod diameter  $d_N = 63.0 \text{ mm}$   
 Series GR69 from Table XXVIII  
 Groove width: 9.70 mm, ring thickness: 2.50 mm

Material: HiMod® HM061  
 (other materials see Table I)

Standard With angle cut  
 design: Design code: 0

TSS Article No.: GR6900630-HM061  
 (from Table XXXIII)

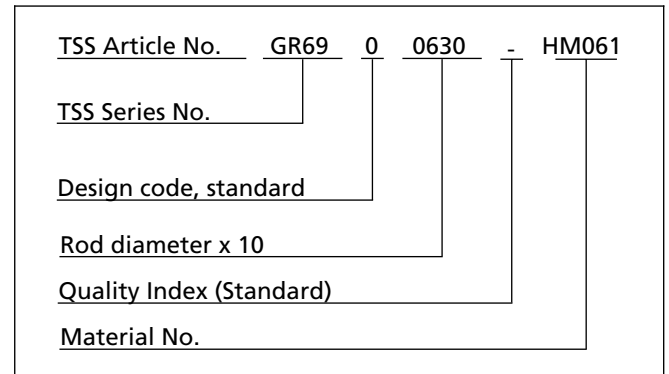

**Note**

HM062 and HM063 materials can be ordered by replacing the HM061 material code in the TSS Article Number.

Please check with your local TSS entity the availability and price of the HM062 or HM063. These materials may require new moulds.

**Table XXXIII Slydring® for Rods in HM061**

Dimensions				TSS Article No.	Polypac Ref. No.
Rod Diameter	Groove Diameter	Groove Width	Thickness		
$d_N$ f8/h9	$D_2$ H8	$L_2$ +0.2	$W$		
<b>20.0</b>	<b>23.1</b>	<b>4.0</b>	<b>1.55</b>	<b>GR4300200-HM061</b>	<b>WR 20 23.1 4</b>
20.0	25.0	5.6	2.50	GR6500200-HM061	WR 20 25 5.6
20.0	25.0	9.7	2.50	GR6900200-HM061	WR 20 25 9.7
22.0	27.0	5.6	2.50	GR6500220-HM061	WR 22 27 5.6
22.0	27.0	9.7	2.50	GR6900220-HM061	WR 22 27 9.7
<b>25.0</b>	<b>28.1</b>	<b>4.0</b>	<b>1.55</b>	<b>GR4300250-HM061</b>	<b>WR 25 28.1 4</b>
<b>25.0</b>	<b>30.0</b>	<b>5.6</b>	<b>2.50</b>	<b>GR6500250-HM061</b>	<b>WR 25 30 5.6</b>
25.0	30.0	9.7	2.50	GR6900250-HM061	WR 25 30 9.7
27.0	32.0	5.6	2.50	GR6500270-HM061	WR 27 32 5.6

All sizes printed in **bold** type conform to ISO 10766 and should be preferred for use.



# HiMod® Slydring® - Wear Ring

Dimensions				TSS Article No.	Polypac Ref. No.
Rod Diameter	Groove Diameter	Groove Width	Thickness		
$d_N$ f8/h9	$D_2$ H8	$L_2$ +0.2	$W$		
27.0	32.0	9.7	2.50	GR6900270-HM061	WR 27 32 9.7
<b>28.0</b>	<b>33.0</b>	<b>5.6</b>	<b>2.50</b>	<b>GR6500280-HM061</b>	<b>WR 28 33 5.6</b>
30.0	35.0	5.6	2.50	GR6500300-HM061	WR 30 35 5.6
30.0	35.0	9.7	2.50	GR6900300-HM061	WR 30 35 9.7
<b>32.0</b>	<b>37.0</b>	<b>5.6</b>	<b>2.50</b>	<b>GR6500320-HM061</b>	<b>WR 32 37 5.6</b>
<b>32.0</b>	<b>37.0</b>	<b>9.7</b>	<b>2.50</b>	<b>GR6900320-HM061</b>	<b>WR 32 37 9.7</b>
35.0	40.0	5.6	2.50	GR6500350-HM061	WR 35 40 5.6
35.0	40.0	9.7	2.50	GR6900350-HM061	WR 35 40 9.7
<b>36.0</b>	<b>41.0</b>	<b>5.6</b>	<b>2.50</b>	<b>GR6500360-HM061</b>	<b>WR 36 41 5.6</b>
<b>36.0</b>	<b>41.0</b>	<b>9.7</b>	<b>2.50</b>	<b>GR6900360-HM061</b>	<b>WR 36 41 9.7</b>
<b>40.0</b>	<b>45.0</b>	<b>5.6</b>	<b>2.50</b>	<b>GR6500400-HM061</b>	<b>WR 40 45 5.6</b>
<b>40.0</b>	<b>45.0</b>	<b>9.7</b>	<b>2.50</b>	<b>GR6900400-HM061</b>	<b>WR 40 45 9.7</b>
40.0	45.0	15.0	2.50	GR7300400-HM061	WR 40 45 15
<b>45.0</b>	<b>50.0</b>	<b>5.6</b>	<b>2.50</b>	<b>GR6500450-HM061</b>	<b>WR 45 50 5.6</b>
<b>45.0</b>	<b>50.0</b>	<b>9.7</b>	<b>2.50</b>	<b>GR6900450-HM061</b>	<b>WR 45 50 9.7</b>
45.0	50.0	15.0	2.50	GR7300450-HM061	WR 45 50 15
47.0	52.0	5.6	2.50	GR6500470-HM061	WR 47 52 5.6
<b>50.0</b>	<b>55.0</b>	<b>5.6</b>	<b>2.50</b>	<b>GR6500500-HM061</b>	<b>WR 50 55 5.6</b>
<b>50.0</b>	<b>55.0</b>	<b>9.7</b>	<b>2.50</b>	<b>GR6900500-HM061</b>	<b>WR 50 55 9.7</b>
50.0	55.0	15.0	2.50	GR7300500-HM061	WR 50 55 15
52.0	57.0	5.6	2.50	GR6500520-HM061	WR 52 57 5.6
52.0	57.0	9.7	2.50	GR6900520-HM061	WR 52 57 9.7
53.0	58.0	9.7	2.50	GR6900530-HM061	WR 53 58 9.7
55.0	60.0	5.6	2.50	GR6500550-HM061	WR 55 60 5.6
55.0	60.0	9.7	2.50	GR6900550-HM061	WR 55 60 9.7
<b>56.0</b>	<b>61.0</b>	<b>5.6</b>	<b>2.50</b>	<b>GR6500560-HM061</b>	<b>WR 56 61 5.6</b>
<b>56.0</b>	<b>61.0</b>	<b>9.7</b>	<b>2.50</b>	<b>GR6900560-HM061</b>	<b>WR 56 61 9.7</b>
58.0	63.0	5.6	2.50	GR6500580-HM061	WR 58 63 5.6
58.0	63.0	9.7	2.50	GR6900580-HM061	WR 58 63 9.7
60.0	65.0	5.6	2.50	GR6500600-HM061	WR 60 65 5.6
60.0	65.0	9.7	2.50	GR6900600-HM061	WR 60 65 9.7
<b>63.0</b>	<b>68.0</b>	<b>5.6</b>	<b>2.50</b>	<b>GR6500630-HM061</b>	<b>WR 63 68 5.6</b>
<b>63.0</b>	<b>68.0</b>	<b>9.7</b>	<b>2.50</b>	<b>GR6900630-HM061</b>	<b>WR 63 68 9.7</b>
63.0	68.0	15.0	2.50	GR7300630-HM061	ER 63 68 15
65.0	70.0	5.6	2.50	GR6500650-HM061	WR 65 70 5.6
65.0	70.0	9.7	2.50	GR6900650-HM061	WR 65 70 9.7

All sizes printed in **bold** type conform to ISO 10766 and should be preferred for use.



Dimensions				TSS Article No.	Polypac Ref. No.
Rod Diameter	Groove Diameter	Groove Width	Thickness		
$d_N$ f8/h9	$D_2$ H8	$L_2$ +0.2	W		
67.0	72.0	5.6	2.50	GR6500670-HM061	WR 67 72 5.6
<b>70.0</b>	<b>75.0</b>	<b>5.6</b>	<b>2.50</b>	<b>GR6500700-HM061</b>	<b>WR 70 75 5.6</b>
<b>70.0</b>	<b>75.0</b>	<b>9.7</b>	<b>2.50</b>	<b>GR6900700-HM061</b>	<b>WR 70 75 9.7</b>
70.0	75.0	15.0	2.50	GR7300700-HM061	WR 70 75 15
75.0	80.0	5.6	2.50	GR6500750-HM061	WR 75 80 5.6
75.0	80.0	9.7	2.50	GR6900750-HM061	WR 75 80 9.7
75.0	80.0	15.0	2.50	GR7300750-HM061	WR 75 80 15
80.0	85.0	5.6	2.50	GR6500800-HM061	WR 80 85 5.6
<b>80.0</b>	<b>85.0</b>	<b>9.7</b>	<b>2.50</b>	<b>GR6900800-HM061</b>	<b>WR 80 85 9.7</b>
<b>80.0</b>	<b>85.0</b>	<b>15.0</b>	<b>2.50</b>	<b>GR7300800-HM061</b>	<b>WR 80 85 15</b>
85.0	90.0	5.6	2.50	GR6500850-HM061	WR 85 90 5.6
85.0	90.0	9.7	2.50	GR6900850-HM061	WR 85 90 9.7
85.0	90.0	15.0	2.50	GR7300850-HM061	WR 85 90 15
90.0	95.0	5.6	2.50	GR6500900-HM061	WR 90 95 5.6
<b>90.0</b>	<b>95.0</b>	<b>9.7</b>	<b>2.50</b>	<b>GR6900900-HM061</b>	<b>WR 90 95 9.7</b>
92.0	97.0	25.0	2.50	GR7500920-HM061	WR 92 97 25
95.0	100.0	5.6	2.50	GR6500950-HM061	WR 95 100 5.6
95.0	100.0	9.7	2.50	GR6900950-HM061	WR 95 100 9.7
95.0	100.0	15.0	2.50	GR7300950-HM061	WR 95 100 15
100.0	105.0	5.6	2.50	GR6501000-HM061	WR 100 105 5.6
<b>100.0</b>	<b>105.0</b>	<b>9.7</b>	<b>2.50</b>	<b>GR6901000-HM061</b>	<b>WR 100 105 9.7</b>
<b>100.0</b>	<b>105.0</b>	<b>15.0</b>	<b>2.50</b>	<b>GR7301000-HM061</b>	<b>WR 100 105 15</b>
105.0	110.0	9.7	2.50	GR6901050-HM061	WR 105 110 9.7
105.0	110.0	15.0	2.50	GR7301050-HM061	WR 105 110 15
<b>110.0</b>	<b>115.0</b>	<b>9.7</b>	<b>2.50</b>	<b>GR6901100-HM061</b>	<b>WR 110 115 9.7</b>
<b>110.0</b>	<b>115.0</b>	<b>15.0</b>	<b>2.50</b>	<b>GR7301100-HM061</b>	<b>WR 110 115 15</b>
115.0	120.0	9.7	2.50	GR6901150-HM061	WR 115 120 9.7
120.0	125.0	5.6	2.50	GR6501200-HM061	WR 120 125 5.6
120.0	125.0	9.7	2.50	GR6901200-HM061	WR 120 125 9.7
120.0	125.0	15.0	2.50	GR7301200-HM061	WR 120 125 15
<b>125.0</b>	<b>130.0</b>	<b>15.0</b>	<b>2.50</b>	<b>GR7301250-HM061</b>	<b>WR 125 130 15</b>
135.0	140.0	9.7	2.50	GR6901350-HM061	WR 135 140 9.7
135.0	140.0	15.0	2.50	GR7301350-HM061	WR 135 140 15
155.0	160.0	15.0	2.50	GR7301550-HM061	WR 155 160 15
195.0	200.0	15.0	2.50	GR7301950-HM061	WR 195 200 15

All sizes printed in **bold** type conform to ISO 10766 and should be preferred for use.



## Installation Recommendation, HiMod® Slydring® for Rod Non ISO 10766 Groove Dimension

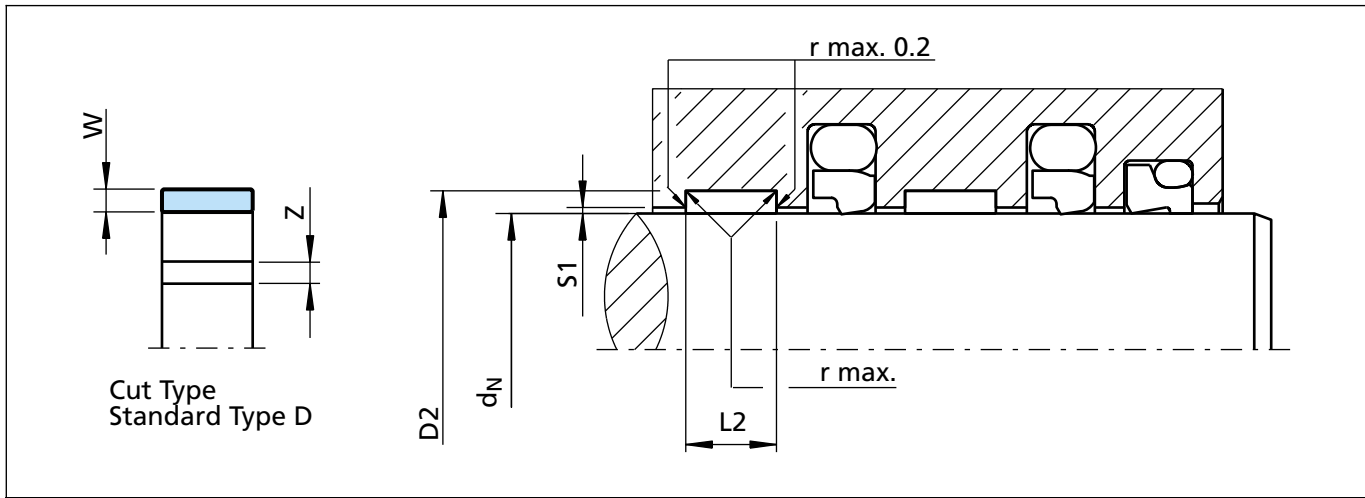

Figure 14 Installation drawing

**Table XXXIV Installation Dimensions HiMod® Slydring® for Rod non ISO 10766 Groove Dimensions**

Serial No.	Groove Diameter	Groove Width	Ring Thickness
	$D_2$ H8	$L_2 + 0.2$	$W$
GR48	$d_N + 4.00$	8.10	2.00
GR49	$d_N + 4.00$	9.70	2.00
GR51	$d_N + 4.00$	10.00	2.00
GRN5	$d_N + 4.00$	12.80	2.00
GR53	$d_N + 4.00$	15.00	2.00
GR54	$d_N + 4.00$	20.00	2.00
GRN1	$d_N + 6.00$	9.70	3.00
GR91	$d_N + 6.00$	10.00	3.00

Serial No.	Groove Diameter	Groove Width	Ring Thickness
	$D_2$ H8	$L_2 + 0.2$	$W$
GR92	$d_N + 6.00$	12.00	3.00
GRN3	$d_N + 6.00$	12.80	3.00
GRN4	$d_N + 6.00$	19.20	3.00
GR94	$d_N + 6.00$	20.00	3.00
GR95	$d_N + 6.00$	25.00	3.00
GR96	$d_N + 6.00$	30.00	3.00
GRL5	$d_N + 8.00$	30.00	4.00

**Table XXXV Recommended Radii for Groove Dia.**

$D_N$	$r$ max.
8 - 250	0.2
>250	0.4

**Table XXXVI Radial Clearance  $S_1$  <sup>2)</sup>**

Rod Dia. $d_N$	$S_1$ min.	$S_1$ max.
8 - 20	0.20	0.30
20 - 100	0.25	0.40
101 - 250	0.30	0.60
251 - 500	0.40	0.80
501 - 1000	0.50	1.10
>1001	0.60	1.20

<sup>2)</sup> Specifications valid only in the area of the Slydring®, but not for the seal area.





**Table XXXVII Recommended Gap**

$d_N$	Ring Gap Z
12 - 40	1 - 1.5
41 - 149	1.5 - 2.5
>150	2 - 4

**Table XXXVIII Surface Roughness**

Parameter	Mating Surface $\mu\text{m}$	Groove Surface $\mu\text{m}$
	HiMod® Materials	
$R_{\text{max}}$	1.00 - 4.00	< 16.0
$R_{z \text{ DIN}}$	0.63 - 2.50	< 10.0
$R_a$	0.10 - 0.40	< 2.5

**Ordering Example**

For Polypac Slydring® Ref. No. I/DWR 40/2  
 Rod diameter  $d_N = 40.0 \text{ mm}$   
 Groove width: 9.70 mm, ring thickness: 2.00 mm

Material: HM061  
 (other materials see Table I)

Standard design: With straight cut  
 Design code: D

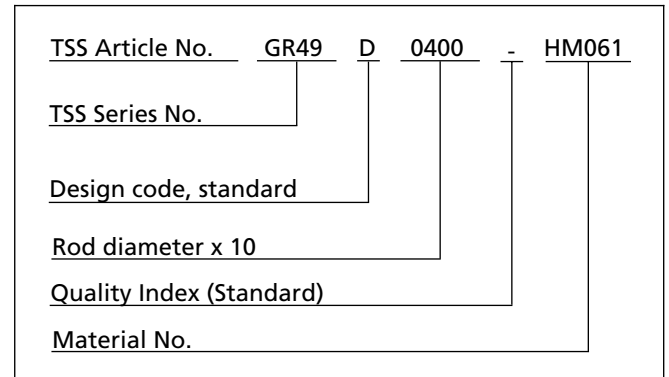

**Note**

HM062 and HM063 materials can be ordered by replacing the HM061 material code in the TSS Article Number.

Please check with your local TSS entity the availability and price of the HM062 or HM063. These materials may require new moulds.

**Table XXXIX Slydring® for Rod in HM061**

Dimensions				TSS Article No.	Polypac Ref. No.
Rod Diameter	Groove Diameter	Groove Width	Thickness		
$d_N \text{ h11}$	$D_2 \text{ H8}$	$L_2 +0.2$	$W$		
12.0	16.0	9.7	2.00	GR49D0120-HM061	I/DWR 12/2-9.6
14.0	18.0	9.7	2.00	GR49D0140-HM061	I/DWR 14/2-9.6
15.0	19.0	9.7	2.00	GR49D0150-HM061	I/DWR 15/2-9.6
16.0	20.0	9.7	2.00	GR49D0160-HM061	I/DWR 16/2-9.6
18.0	22.0	9.7	2.00	GR49D0180-HM061	I/DWR 18/2-9.6
20.0	24.0	9.7	2.00	GR49D0200-HM061	I/DWR 20/2-9.6
22.0	26.0	9.7	2.00	GR49D0220-HM061	I/DWR 22/2-9.6
24.0	28.0	9.7	2.00	GR49D0240-HM061	I/DWR 24/2-9.6
25.0	29.0	9.7	2.00	GR49D0250-HM061	I/DWR 25/2-9.6
26.0	30.0	9.7	2.00	GR49D0260-HM061	I/DWR 26/2-9.6
27.0	31.0	9.7	2.00	GR49D0270-HM061	I/DWR 27/2-9.6
28.0	32.0	9.7	2.00	GR49D0280-HM061	I/DWR 28/2-9.6



# HiMod® Slydring® - Wear Ring

Dimensions				TSS Article No.	Polypac Ref. No.
Rod Diameter	Groove Diameter	Groove Width	Thickness		
$d_N$ h11	$D_2$ H8	$L_2$ +0.2	$W$		
30.0	34.0	9.7	2.00	GR49D0300-HM061	I/DWR 30/2-9.6
30.0	36.0	9.7	3.00	GRN1D0300-HM061	I/DWR 30/3-9.6
31.0	35.0	9.7	2.00	GR49D0310-HM061	I/DWR 31/2-9.6
32.0	36.0	9.7	2.00	GR49D0320-HM061	I/DWR 32/2-9.6
34.0	38.0	9.7	2.00	GR49D0340-HM061	I/DWR 34/2-9.6
35.0	39.0	9.7	2.00	GR49D0350-HM061	I/DWR 35/2-9.6
35.0	41.0	9.7	3.00	GRN1D0350-HM061	I/DWR 35/3-9.6
35.0	39.0	12.8	2.00	GRN5D0350-HM061	I/DWR 35/2-12.8
36.0	40.0	9.7	2.00	GR49D0360-HM061	I/DWR 36/2-9.6
36.0	42.0	9.7	3.00	GRN1D0360-HM061	I/DWR 36/3-9.6
37.0	41.0	9.7	2.00	GR49D0370-HM061	I/DWR 37/2-9.6
38.0	42.0	9.7	2.00	GR49D0380-HM061	I/DWR 38/2-9.6
40.0	44.0	9.7	2.00	GR49D0400-HM061	I/DWR 40/2-9.6
40.0	46.0	9.7	3.00	GRN1D0400-HM061	I/DWR 40/3-9.6
40.0	46.0	12.8	3.00	GRN3D0400-HM061	I/DWR 40/3-12.8
42.0	46.0	9.7	2.00	GR49D0420-HM061	I/DWR 42/2-9.6
42.0	48.0	9.7	3.00	GRN1D0420-HM061	I/DWR 42/3-9.6
44.0	50.0	9.7	3.00	GRN1D0440-HM061	I/DWR 44/3-9.6
45.0	51.0	9.7	3.00	GRN1D0450-HM061	I/DWR 45/3-9.6
45.0	51.0	12.8	3.00	GRN3D0450-HM061	I/DWR 45/3-12.8
46.0	50.0	9.7	2.00	GR49D0460-HM061	I/DWR 46/2-9.6
46.0	52.0	9.7	3.00	GRN1D0460-HM061	I/DWR 46/3-9.6
47.0	53.0	9.7	3.00	GRN1D0470-HM061	I/DWR 47/3-9.6
48.0	54.0	9.7	3.00	GRN1D0480-HM061	I/DWR 48/3-9.6
48.0	52.0	12.8	2.00	GRN5D0480-HM061	I/DWR 48/2-12.8
50.0	54.0	9.7	2.00	GR49D0500-HM061	I/DWR 50/2-9.6
50.0	56.0	9.7	3.00	GRN1D0500-HM061	I/DWR 50/3-9.6
50.0	56.0	12.8	3.00	GRN3D0500-HM061	I/DWR 50/3-12.8
52.0	58.0	9.7	3.00	GRN1D0520-HM061	I/DWR 52/3-9.6
53.0	59.0	9.7	3.00	GRN1D0530-HM061	I/DWR 53/3-9.6
54.0	60.0	9.7	3.00	GRN1D0540-HM061	I/DWR 54/3-9.6
54.0	60.0	12.8	3.00	GRN3D0540-HM061	I/DWR 54/3-12.8
55.0	59.0	9.7	2.00	GR49D0550-HM061	I/DWR 55/2-9.6
55.0	61.0	9.7	3.00	GRN1D0550-HM061	I/DWR 55/3-9.6
55.0	61.0	12.8	3.00	GRN3D0550-HM061	I/DWR 55/3-12.8
56.0	62.0	9.7	3.00	GRN1D0560-HM061	I/DWR 56/3-9.6





Dimensions				TSS Article No.	Polypac Ref. No.
Rod Diameter	Groove Diameter	Groove Width	Thickness		
$d_N$ h11	$D_2$ H8	$L_2$ +0.2	W		
56.0	62.0	12.8	3.00	GRN3D0560-HM061	I/DWR 56/3-12.8
58.0	64.0	12.8	3.00	GRN3D0580-HM061	I/DWR 58/3-12.8
60.0	64.0	9.7	2.00	GR49D0600-HM061	I/DWR 60/2-9.6
60.0	66.0	9.7	3.00	GRN1D0600-HM061	I/DWR 60/3-9.6
60.0	66.0	12.8	3.00	GRN3D0600-HM061	I/DWR 60/3-12.8
61.0	67.0	12.8	3.00	GRN3D0610-HM061	I/DWR 61/3-12.8
62.0	68.0	12.8	3.00	GRN3D0620-HM061	I/DWR 62/3-12.8
63.0	69.0	12.8	3.00	GRN3D0630-HM061	I/DWR 63/3-12.8
65.0	71.0	12.8	3.00	GRN3D0650-HM061	I/DWR 65/3-12.8
66.0	72.0	12.8	3.00	GRN3D0660-HM061	I/DWR 66/3-12.8
67.0	73.0	12.8	3.00	GRN3D0670-HM061	I/DWR 67/3-12.8
69.0	75.0	12.8	3.00	GRN3D0690-HM061	I/DWR 69/3-12.8
70.0	76.0	12.8	3.00	GRN3D0700-HM061	I/DWR 70/3-12.8
70.0	76.0	19.2	3.00	GRN4D0700-HM061	I/DWR 70/3-19.2
72.0	78.0	12.8	3.00	GRN3D0720-HM061	I/DWR 72/3-12.8
73.0	79.0	12.8	3.00	GRN3D0730-HM061	I/DWR 73/3-12.8
75.0	81.0	12.8	3.00	GRN3D0750-HM061	I/DWR 75/3-12.8
75.0	81.0	19.2	3.00	GRN4D0750-HM061	I/DWR 75/3-19.2
76.0	82.0	12.8	3.00	GRN3D0760-HM061	I/DWR 76/3-12.8
78.0	84.0	12.8	3.00	GRN3D0780-HM061	I/DWR 78/3-12.8
79.0	85.0	12.8	3.00	GRN3D0790-HM061	I/DWR 79/3-12.8
80.0	86.0	12.8	3.00	GRN3D0800-HM061	I/DWR 80/3-12.8
80.0	86.0	19.2	3.00	GRN4D0800-HM061	I/DWR 80/3-19.2
82.0	88.0	12.8	3.00	GRN3D0820-HM061	I/DWR 82/3-12.8
84.0	90.0	12.8	3.00	GRN3D0840-HM061	I/DWR 84/3-12.8
85.0	91.0	12.8	3.00	GRN3D0850-HM061	I/DWR 85/3-12.8
85.0	91.0	19.2	3.00	GRN4D0850-HM061	I/DWR 85/3-19.2
86.0	92.0	12.8	3.00	GRN3D0860-HM061	I/DWR 86/3-12.8
88.0	94.0	12.8	3.00	GRN3D0880-HM061	I/DWR 88/3-12.8
90.0	96.0	12.8	3.00	GRN3D0900-HM061	I/DWR 90/3-12.8
90.0	96.0	19.2	3.00	GRN4D0900-HM061	I/DWR 90/3-19.2
91.0	97.0	12.8	3.00	GRN3D0910-HM061	I/DWR 91/3-12.8
92.0	98.0	12.8	3.00	GRN3D0920-HM061	I/DWR 92/3-12.8
93.0	99.0	12.8	3.00	GRN3D0930-HM061	I/DWR 93/3-12.8
95.0	101.0	12.8	3.00	GRN3D0950-HM061	I/DWR 95/3-12.8
95.0	101.0	19.2	3.00	GRN4D0950-HM061	I/DWR 95/3-19.2



# HiMod® Slydring® - Wear Ring

Dimensions				TSS Article No.	Polypac Ref. No.
Rod Diameter	Groove Diameter	Groove Width	Thickness		
$d_N$ h11	$D_2$ H8	$L_2$ +0.2	$W$		
96.0	102.0	12.8	3.00	GRN3D0960-HM061	I/DWR 96/3-12.8
97.0	103.0	12.8	3.00	GRN3D0970-HM061	I/DWR 97/3-12.8
98.0	104.0	12.8	3.00	GRN3D0980-HM061	I/DWR 98/3-12.8
99.0	105.0	12.8	3.00	GRN3D0990-HM061	I/DWR 99/3-12.8
99.0	105.0	19.2	3.00	GRN4D0990-HM061	I/DWR 99/3-19.2
100.0	106.0	12.8	3.00	GRN3D1000-HM061	I/DWR 100/3-12.8
100.0	106.0	19.2	3.00	GRN4D1000-HM061	I/DWR 100/3-19.2
101.0	107.0	12.8	3.00	GRN3D1010-HM061	I/DWR 101/3-12.8
105.0	111.0	12.8	3.00	GRN3D1050-HM061	I/DWR 105/3-12.8
105.0	111.0	19.2	3.00	GRN4D1050-HM061	I/DWR 105/3-19.2
106.0	112.0	19.2	3.00	GRN4D1060-HM061	I/DWR 106/3-19.2
107.0	113.0	12.8	3.00	GRN3D1070-HM061	I/DWR 107/3-12.8
109.0	115.0	12.8	3.00	GRN3D1090-HM061	I/DWR 109/3-12.8
110.0	116.0	12.8	3.00	GRN3D1100-HM061	I/DWR 110/3-12.8
113.0	119.0	12.8	3.00	GRN3D1130-HM061	I/DWR 113/3-12.8
115.0	121.0	12.8	3.00	GRN3D1150-HM061	I/DWR 115/3-12.8
115.0	121.0	19.2	3.00	GRN4D1150-HM061	I/DWR 115/3-19.2
117.0	123.0	12.8	3.00	GRN3D1170-HM061	I/DWR 117/3-12.8
118.0	124.0	12.8	3.00	GRN3D1180-HM061	I/DWR 118/3-12.8
120.0	126.0	12.8	3.00	GRN3D1200-HM061	I/DWR 120/3-12.8
120.0	126.0	19.2	3.00	GRN4D1200-HM061	I/DWR 120/3-19.2
123.0	129.0	12.8	3.00	GRN3D1230-HM061	I/DWR 123/3-12.8
125.0	131.0	12.8	3.00	GRN3D1250-HM061	I/DWR 125/3-12.8
125.0	131.0	19.2	3.00	GRN4D1250-HM061	I/DWR 125/3-19.2
126.0	132.0	12.8	3.00	GRN3D1260-HM061	I/DWR 126/3-12.8
127.0	133.0	12.8	3.00	GRN3D1270-HM061	I/DWR 127/3-12.8
129.0	135.0	19.2	3.00	GRN4D1290-HM061	I/DWR 129/3-19.2
130.0	136.0	12.8	3.00	GRN3D1300-HM061	I/DWR 130/3-12.8
131.0	137.0	12.8	3.00	GRN3D1310-HM061	I/DWR 131/3-12.8
132.0	138.0	12.8	3.00	GRN3D1320-HM061	I/DWR 132/3-12.8
135.0	141.0	12.8	3.00	GRN3D1350-HM061	I/DWR 135/3-12.8
138.0	144.0	12.8	3.00	GRN3D1380-HM061	I/DWR 138/3-12.8
139.0	145.0	19.2	3.00	GRN4D1390-HM061	I/DWR 139/3-19.2
140.0	146.0	12.8	3.00	GRN3D1400-HM061	I/DWR 140/3-12.8
141.0	147.0	12.0	3.00	GR92D1410-HM061	I/DWR 141/3-12.0
141.0	147.0	12.8	3.00	GRN3D1410-HM061	I/DWR 141/3-12.8



Dimensions				TSS Article No.	Polypac Ref. No.
Rod Diameter	Groove Diameter	Groove Width	Thickness		
$d_N$ h11	$D_2$ H8	$L_2$ +0.2	W		
141.0	147.0	19.2	3.00	GRN4D1410-HM061	I/DWR 141/3-19.2
142.0	148.0	12.8	3.00	GRN3D1420-HM061	I/DWR 142/3-12.8
143.0	149.0	12.8	3.00	GRN3D1430-HM061	I/DWR 143/3-12.8
145.0	151.0	12.8	3.00	GRN3D1450-HM061	I/DWR 145/3-12.8
145.0	151.0	19.2	3.00	GRN4D1450-HM061	I/DWR 145/3-19.2
148.0	154.0	12.8	3.00	GRN3D1480-HM061	I/DWR 148/3-12.8
150.0	156.0	12.8	3.00	GRN3D1500-HM061	I/DWR 150/3-12.8
150.0	156.0	19.2	3.00	GRN4D1500-HM061	I/DWR 150/3-19.2
152.0	158.0	12.8	3.00	GRN3D1520-HM061	I/DWR 152/3-12.8
152.0	158.0	19.2	3.00	GRN4D1520-HM061	I/DWR 152/3-19.2
154.0	160.0	19.2	3.00	GRN4D1540-HM061	I/DWR 154/3-19.2
155.0	161.0	19.2	3.00	GRN4D1550-HM061	I/DWR 155/3-19.2
160.0	166.0	19.2	3.00	GRN4D1600-HM061	I/DWR 160/3-19.2
162.0	168.0	19.2	3.00	GRN4D1620-HM061	I/DWR 162/3-19.2
163.0	169.0	19.2	3.00	GRN4D1630-HM061	I/DWR 163/3-19.2
165.0	171.0	19.2	3.00	GRN4D1650-HM061	I/DWR 165/3-19.2
170.0	176.0	19.2	3.00	GRN4D1700-HM061	I/DWR 170/3-19.2
173.0	179.0	19.2	3.00	GRN4D1730-HM061	I/DWR 173/3-19.2
175.0	181.0	19.2	3.00	GRN4D1750-HM061	I/DWR 175/3-19.2
180.0	186.0	12.8	3.00	GRN3D1800-HM061	I/DWR 180/3-12.8
180.0	186.0	19.2	3.00	GRN4D1800-HM061	I/DWR 180/3-19.2
183.0	189.0	19.2	3.00	GRN4D1830-HM061	I/DWR 183/3-19.2
184.0	190.0	19.2	3.00	GRN4D1840-HM061	I/DWR 184/3-19.2
185.0	191.0	19.2	3.00	GRN4D1850-HM061	I/DWR 185/3-19.2
190.0	196.0	19.2	3.00	GRN4D1900-HM061	I/DWR 190/3-19.2
195.0	201.0	19.2	3.00	GRN4D1950-HM061	I/DWR 195/3-19.2
196.0	202.0	19.2	3.00	GRN4D1960-HM061	I/DWR 196/3-19.2
198.0	204.0	19.2	3.00	GRN4D1980-HM061	I/DWR 198/3-19.2
200.0	206.0	19.2	3.00	GRN4D2000-HM061	I/DWR 200/3-19.2
205.0	211.0	19.2	3.00	GRN4D2050-HM061	I/DWR 205/3-19.2
210.0	216.0	19.2	3.00	GRN4D2100-HM061	I/DWR 210/3-19.2
215.0	221.0	19.2	3.00	GRN4D2150-HM061	I/DWR 215/3-19.2
220.0	226.0	19.2	3.00	GRN4D2200-HM061	I/DWR 220/3-19.2
225.0	231.0	19.2	3.00	GRN4D2250-HM061	I/DWR 225/3-19.2
230.0	236.0	19.2	3.00	GRN4D2300-HM061	I/DWR 230/3-19.2
231.0	237.0	19.2	3.00	GRN4D2310-HM061	I/DWR 231/3-19.2



## HiMod® Slydring® - Wear Ring

Dimensions				TSS Article No.	Polypac Ref. No.
Rod Diameter	Groove Diameter	Groove Width	Thickness		
$d_N$ h11	$D_2$ H8	$L_2$ +0.2	$W$		
235.0	241.0	19.2	3.00	GRN4D2350-HM061	I/DWR 235/3-19.2
240.0	246.0	19.2	3.00	GRN4D2400-HM061	I/DWR 240/3-19.2
245.0	251.0	19.2	3.00	GRN4D2450-HM061	I/DWR 245/3-19.2
248.0	254.0	19.2	3.00	GRN4D2480-HM061	I/DWR 248/3-19.2
250.0	256.0	19.2	3.00	GRN4D2500-HM061	I/DWR 250/3-19.2
254.0	260.0	19.2	3.00	GRN4D2540-HM061	I/DWR 254/3-19.2
255.0	261.0	19.2	3.00	GRN4D2550-HM061	I/DWR 255/3-19.2
260.0	266.0	19.2	3.00	GRN4D2600-HM061	I/DWR 260/3-19.2
265.0	271.0	19.2	3.00	GRN4D2650-HM061	I/DWR 265/3-19.2
270.0	276.0	19.2	3.00	GRN4D2700-HM061	I/DWR 270/3-19.2
275.0	281.0	19.2	3.00	GRN4D2750-HM061	I/DWR 275/3-19.2
280.0	286.0	19.2	3.00	GRN4D2800-HM061	I/DWR 280/3-19.2
285.0	291.0	19.2	3.00	GRN4D2850-HM061	I/DWR 285/3-19.2
290.0	296.0	19.2	3.00	GRN4D2900-HM061	I/DWR 290/3-19.2
295.0	301.0	19.2	3.00	GRN4D2950-HM061	I/DWR 295/3-19.2
300.0	306.0	19.2	3.00	GRN4D3000-HM061	I/DWR 300/3-19.2



## ■ Orkot® Slydring® for Piston and Rod

### Description

Orkot® Slydring® of fabric reinforced composite materials is used in hydraulic cylinders exposed to high loads that can occur e.g. in mobile hydraulics and presses. The high compressive strength, good sliding behaviour and the exceptional wear resistant properties ensure a long service life.

Slydring® of Orkot® fabric composite materials is produced as standard from tubular material. It is manufactured with an angle cut and already has the necessary gap "Z1".

For large diameters > 300 mm, rings can be cut from Orkot® C320, C380 strip material. This offers economical solutions for non-standard diameters or when quantities are limited. Strip material is coiled to a diameter of 200 to 300 mm and can be ordered either:

- cut and finished to the required length (see page 5)
- coils at full lengths of 2 m, 3 m or 5 m (see next page)

Strip material requires more care in fitting, in particular if the diameter is below 200 to 300 mm.

### Advantages

- Dimensionally stable and vibration absorbing
- Even distribution of high radial forces
- Good sliding and dry running properties
- High wear resistance
- Good wiping effect
- Long service life.

### Application Examples

Orkot® Slydring is widely used as a bearing element for heavy duty hydraulic equipment:

- Hydraulic actuators
- Mobile hydraulics
- Excavators
- Construction equipment
- Forestry machinery
- Mining
- Steel mills
- Presses
- Water locks
- Marine engineering

### Technical Data

Velocity: Up to 1 m/s, with reciprocating movements

Temperature: - 60°C to + 120°C

Pr under dynamic conditions (C380, C320, C932):  
 max. 100 N/mm<sup>2</sup> at 25°C  
 max. 50 N/mm<sup>2</sup> >60°C

Ultimate compressive strength (C380, C320):  
 max. > 300 N/mm<sup>2</sup>  
 (C932): max. 260 N/mm<sup>2</sup>

When calculating the width of Orkot® Slydring® it is recommended to use a safety factor f=2 (see page 8).

#### Important Note:

The above stated limits for pressure and speed are maximum values individually. Friction heat generated by the combination of pressure and speed may cause local heat built-up. Care should be taken not to apply high values for pressure and speed at the same time.

### Materials

#### Orkot® C320

Orkot® C320 is a fabric composite material made of a thermosetting polymer, reinforced by a fine plastic mesh and lubricant additives impregnated throughout the material. It has a very high resistance to wear, good dry-running properties and dampens vibrations. Colour: dark gray.

#### Orkot® C380

Orkot C380 is the standard material, this turquoise coloured composite is a further development of the proven C320. It is most versatile; suitable for all commonly used hydraulic fluids such as mineral or synthetic oils, as well as water based fluids. It is an excellent electrical insulator and features enhanced sliding properties in various media.

#### Orkot® C932

A composite of phenolic resin impregnated into a fine cotton fabric. The material stiffness is higher than C380 / C320. The use in water based fluids is not recommended. Colour: yellow-brown.





# Orkot® Slydring® - Wear Ring

**Table XL Serial Numbers for Orkot® Slydring®, made from tube, ready-to-fit**

Piston Serial No.	Rod Serial No.	Groove Width	Ring Thickness
GP41	GR41	2.5	1.55
<b>GP43</b>	<b>GR43</b>	<b>4.0</b>	<b>1.55</b>
GP47	GR47	6.3	1.55
GP48	GR48	8.1	2.00
GP49	GR49	9.7	2.00
GP51	GR51	10.0	2.00
GP53	GR53	15.0	2.00
GP64	GR64	4.2	2.50
<b>GP65</b>	<b>GR65</b>	<b>5.6</b>	<b>2.50</b>
GP67	GR67	6.3	2.50
GP68	GR68	8.1	2.50
<b>GP69</b>	<b>GR69</b>	<b>9.7</b>	<b>2.50</b>
<b>GP73</b>	<b>GR73</b>	<b>15.0</b>	<b>2.50</b>
GP74	GR74	20.0	2.50
<b>GP75</b>	<b>GR75</b>	<b>25.0</b>	<b>2.50</b>
GP76	GR76	30.0	2.50
GP77	GR77	35.0	2.50
GP93	GR93	15.0	3.00
GP94	GR94	20.0	3.00
GP95	GR95	25.0	3.00
GP96	GR96	30.0	3.00
GP99	GR99	9.7	4.00
GPL2	GRL2	15.0	4.00
GPL3	GRL3	20.0	4.00
<b>GP98</b>	<b>GR98</b>	<b>25.0</b>	<b>4.00</b>
GPL5	GRL5	30.0	4.00
GPL7	GRL7	40.0	4.00
GPL9	GRL9	50.0	4.00

Note that customer specific sizes can be supplied without tooling costs.

**Table XLI Serial Numbers for Orkot® Slydring®, Coiled Strip, to be cut to length**

Serial Number	Coiled length	Groove Width	Ring Thickness
GM65A0000-C380	2 m	5.6	2.50
GM69A0000-C380	2 m	9.7	2.50
GM69A3000-C380	3 m	9.7	2.50
GM69A5000-C380	5 m	9.7	2.50
GM73A0000-C380	2 m	15.0	2.50

Serial Number	Coiled length	Groove Width	Ring Thickness
GM73A3000-C380	3 m	15.0	2.50
GM73A5000-C380	5 m	15.0	2.50
GM74A0000-C380	2 m	20.0	2.50
GM74A3000-C380	3 m	20.0	2.50
GM74A5000-C380	5 m	20.0	2.50
GM75A0000-C380	2 m	25.0	2.50
GM75A3000-C380	3 m	25.0	2.50
GM75A5000-C380	5 m	25.0	2.50
GM76A0000-C380	2 m	30.0	2.50
GM78A5000-C380	5 m	40.0	2.50
GM95A0000-C380	2 m	25.0	3.00
GM95A5000-C380	5 m	25.0	3.00
GM98A0000-C380	2 m *	25.0	4.00
GM98A3000-C380	3 m *	25.0	4.00
GM98A5000-C380	5 m *	25.0	4.00
GML7A3000-C380	3 m *	40.0	4.00
GML7A5000-C380	5 m *	40.0	4.00

Coils have an inside diameter of approximately 200 mm  
\* 4 mm strip is coiled at 700 mm diam. approximately

## Installation Recommendations

In order to protect the seal and guide system against ingress of foreign particles, we recommend the use of Turcite® Slydring® in combination with Orkot® Slydring®. The larger face area of these rings (Series GP 99 from Table IV) embeds the contaminant particles when present in the system and keeps them away from the actual guides and seals (Figure 15). Reducing the piston diameter at both ends allows the particles to become embedded on the face side.

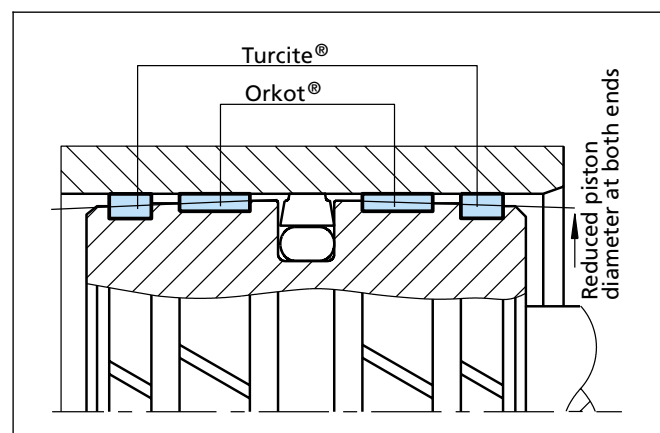

Figure 15 Arrangement of the Slydring® on the piston





## ■ Installation Recommendation, Orkot® Slydring® for Piston According to ISO 10766 Groove Dimension

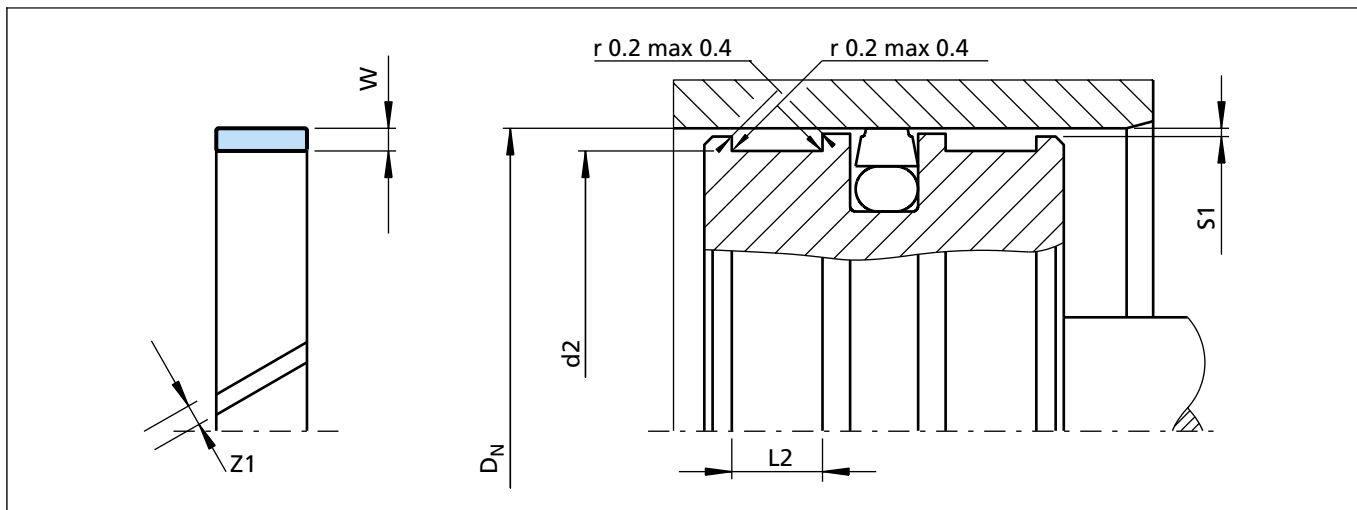

Figure 16 Installation drawing

**Table XLII Installation Dimensions**

Serial No.	Bore Diameter <sup>1)</sup>	Groove Diameter	Groove Width	Ring Thickness	Ring Gap <sup>2)</sup>
	$D_N$ H9	$d_2$ h8	$L_2 +0.2$	$W$	$Z1$
GP43	16 - 50.0	$D_N -3.10$	4.00	1.55	1 - 3
GP65	16 - 125.0	$D_N -5.00$	5.60	2.50	2 - 6
GP69	25 - 250.0	$D_N -5.00$	9.70	2.50	2 - 9
GP73	80 - 500.0	$D_N -5.00$	15.00	2.50	4 - 17
GP75	125 - 999.9	$D_N -5.00$	25.00	2.50	6 - 33
GP75X	1000 - 1500.0	$D_N -5.00$	25.00	2.50	33 - 48
GP98	280 - 999.9	$D_N -8.00$	25.00	4.00	10 - 33
GP98X	1000 - 1500.0	$D_N -8.00$	25.00	4.00	33 - 48

<sup>1)</sup> Recommended diameter ranges.

<sup>2)</sup> see figure 17.

For Slydring® to other standards, e.g French standard NF E 48-037, please contact us.

### Radial clearance S1

The minimum radial gap is to be calculated taking into account;

- the fitting tolerances of the hardware
- the tolerance on the ring thickness
- an allowance for wear
- in case of high radial loads an allowance for elastic deformation
- a safety margin to avoid metal-to-metal contact

The gaps S1 can be chosen larger than near to the seal (attention: take care of gap dimension for the seal) thus allowing slight tilting of the piston, still without metal-to-metal contact.

It also allows foreign particles to be wiped away by the Slydring® rather than being squeezed between the metal components. The slot 'Z1' allows fluid to pass across the ring thus preventing fluid pressure build-up which might cause extrusion of the guide ring. To ensure the ring cannot escape out of the groove it is recommended to observe following radial gap sizes as maximum:

- 0.50 mm for GP43 ( 1.55 mm thickness)
- 0.90 mm for GP65 to GP75 ( 2.50 mm thickness)
- 1.50 mm for GP98 and GP98X ( 4.00 mm thickness)



# Orkot<sup>®</sup> Slydring<sup>®</sup> - Wear Ring

Table XLIII Recommended Radii for Groove Dia.

D <sub>N</sub>	r max.
8 - 250	0.2
> 250	0.4

Table XLIV Surface Roughness

Parameter	Mating Surface $\mu\text{m}$	Groove Surface $\mu\text{m}$
R <sub>max</sub>	1.00 - 4.00	< 16.0
R <sub>z</sub> DIN	0.63 - 2.50	< 10.0
R <sub>a</sub>	0.10 - 0.40	< 2.5

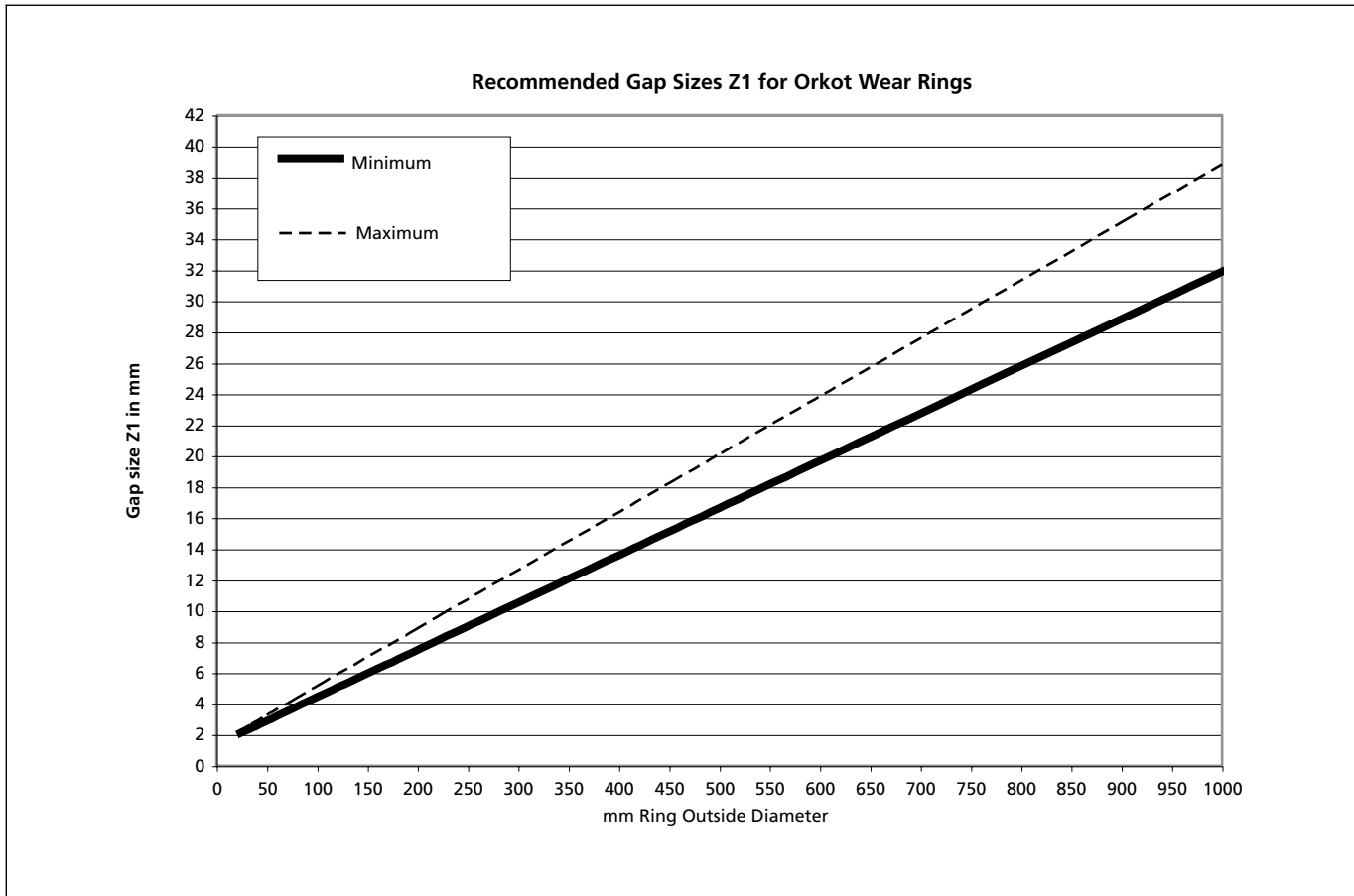

Figure 17 Recommended Gap Sizes Z1 for Orkot Wear Ring



## Ordering Example

Slydring® for bore diameter  $D_N = 100.0$  mm  
 Series GP 69 from Table XLII  
 Groove width: 9.7 mm, ring thickness: 2.50 mm

Material: Orkot® C380  
 (other materials see Table I)

Standard design: With angle cut  
 Design code: 0

TSS Part No.: GP6901000  
 (from Table XLV)

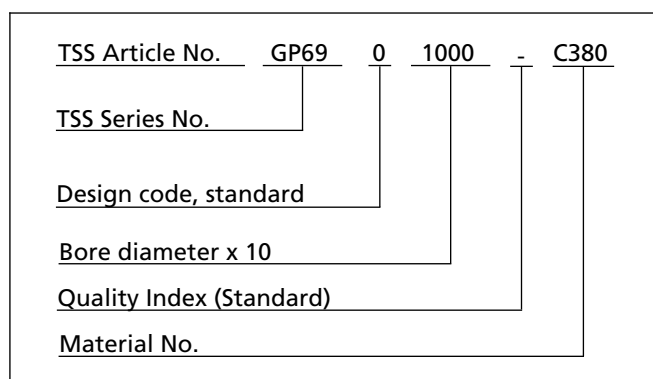

The TSS Article No. can be formed from the example above.

## Ordering Example for diameter > 1000 mm

Slydring® for bore diameter  $D_N = 1200.0$  mm  
 Series GP75X from Table XLII  
 Groove width: 25.0 mm, ring thickness: 2.50 mm

Material: Orkot® C380

TSS Part No.: GP75X1200  
 (from Table XLV)

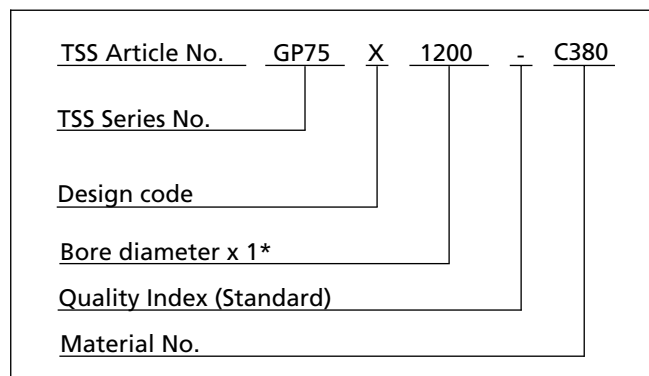

\* For diameters  $\geq 1000.0$  mm multiply only by factor 1.

## Please Note

Orkot® Slydring® for pistons can be used as rod guide ring, f.inst.

### GP69 0 1000 - C380

is identical and can be replaced with

### GR69 0 0950 - C380

**Table XLV Slydring® for Pistons**

Dimensions				TSS Part No.
Bore Diameter	Groove Diameter	Groove Width	Thickness	
$D_N$ H9	$d_2$ h8	$L_2$ +0.2	$W$	
<b>16.0</b>	<b>11.0</b>	<b>5.6</b>	<b>2.50</b>	<b>GP6500160</b>
18.0	13.0	5.6	2.50	GP6500180
<b>20.0</b>	<b>15.0</b>	<b>5.6</b>	<b>2.50</b>	<b>GP6500200</b>
22.0	17.0	5.6	2.50	GP6500220
<b>25.0</b>	<b>20.0</b>	<b>5.6</b>	<b>2.50</b>	<b>GP6500250</b>
25.0	20.0	9.7	2.50	GP6900250
27.0	22.0	5.6	2.50	GP6500270
28.0	23.0	5.6	2.50	GP6500280
30.0	25.0	9.7	2.50	GP6900300

All sizes printed in **bold** type conform to ISO 10766 and should be preferred for use. Additional sizes not covered by this list are also held in stock. Also please note that customer specific sizes can be supplied without tooling costs.



# Orkot<sup>®</sup> Slydring<sup>®</sup> - Wear Ring

Dimensions				TSS Part No.
Bore Diameter	Groove Diameter	Groove Width	Thickness	
<b>D<sub>N</sub></b> H9	<b>d<sub>2</sub></b> h8	<b>L<sub>2</sub></b> +0.2	<b>W</b>	
<b>32.0</b>	<b>28.9</b>	<b>4.0</b>	<b>1.55</b>	<b>GP4300320</b>
<b>32.0</b>	<b>27.0</b>	<b>5.6</b>	<b>2.50</b>	<b>GP6500320</b>
32.0	27.0	9.7	2.50	GP6900320
33.0	28.0	5.6	2.50	GP6500330
35.0	30.0	5.6	2.50	GP6500350
35.0	30.0	9.7	2.50	GP6900350
36.0	31.0	5.6	2.50	GP6500360
36.0	31.0	9.7	2.50	GP6900360
37.0	32.0	9.7	2.50	GP6900370
<b>40.0</b>	<b>36.9</b>	<b>4.0</b>	<b>1.55</b>	<b>GP4300400</b>
<b>40.0</b>	<b>35.0</b>	<b>5.6</b>	<b>2.50</b>	<b>GP6500400</b>
40.0	35.0	9.7	2.50	GP6900400
41.0	36.0	5.6	2.50	GP6500410
41.0	36.0	9.7	2.50	GP6900410
42.0	37.0	5.6	2.50	GP6500420
44.0	39.0	5.6	2.50	GP6500440
45.0	40.0	5.6	2.50	GP6500450
45.0	40.0	9.7	2.50	GP6900450
46.0	41.0	9.7	2.50	GP6900460
48.0	43.0	5.6	2.50	GP6500480
<b>50.0</b>	<b>45.0</b>	<b>5.6</b>	<b>2.50</b>	<b>GP6500500</b>
50.0	45.0	9.7	2.50	GP6900500
51.0	46.0	9.7	2.50	GP6900510
51.0	46.0	15.0	2.50	GP7300510
52.0	47.0	5.6	2.50	GP6500520
53.0	48.0	5.6	2.50	GP6500530
55.0	50.0	5.6	2.50	GP6500550
55.0	50.0	9.7	2.50	GP6900550
58.0	53.0	5.6	2.50	GP6500580
60.0	55.0	5.6	2.50	GP6500600
60.0	55.0	9.7	2.50	GP6900600
61.0	56.0	5.6	2.50	GP6500610
62.0	57.0	5.6	2.50	GP6500620

All sizes printed in **bold** type conform to ISO 10766 and should be preferred for use. Additional sizes not covered by this list are also held in stock. Also please note that customer specific sizes can be supplied without tooling costs.



Dimensions				TSS Part No.
Bore Diameter	Groove Diameter	Groove Width	Thickness	
$D_N$ H9	$d_2$ h8	$L_2$ +0.2	W	
62.0	56.0	9.7	2.50	GP6900610
<b>63.0</b>	<b>58.0</b>	<b>5.6</b>	<b>2.50</b>	<b>GP6500630</b>
<b>63.0</b>	<b>58.0</b>	<b>9.7</b>	<b>2.50</b>	<b>GP6900630</b>
65.0	60.0	5.6	2.50	GP6500650
65.0	60.0	9.7	2.50	GP6900650
68.0	63.0	5.6	2.50	GP6500680
68.0	63.0	9.7	2.50	GP6900680
70.0	65.0	5.6	2.50	GP6500700
70.0	65.0	9.7	2.50	GP6900700
74.0	69.0	5.6	2.50	GP6500740
75.0	70.0	5.6	2.50	GP6500750
75.0	70.0	9.7	2.50	GP6900750
<b>80.0</b>	<b>75.0</b>	<b>5.6</b>	<b>2.50</b>	<b>GP6500800</b>
<b>80.0</b>	<b>75.0</b>	<b>9.7</b>	<b>2.50</b>	<b>GP6900800</b>
<b>80.0</b>	<b>75.0</b>	<b>25.0</b>	<b>2.50</b>	<b>GP7500800</b>
85.0	80.0	5.6	2.50	GP6500850
85.0	80.0	9.7	2.50	GP6900850
90.0	85.0	5.6	2.50	GP6500900
90.0	85.0	9.7	2.50	GP6900900
95.0	90.0	5.6	2.50	GP6500950
95.0	90.0	9.7	2.50	GP6900950
<b>100.0</b>	<b>95.0</b>	<b>5.6</b>	<b>2.50</b>	<b>GP6501000</b>
<b>100.0</b>	<b>95.0</b>	<b>9.7</b>	<b>2.50</b>	<b>GP6901000</b>
<b>100.0</b>	<b>95.0</b>	<b>15.0</b>	<b>2.50</b>	<b>GP7301000</b>
<b>100.0</b>	<b>95.0</b>	<b>25.0</b>	<b>2.50</b>	<b>GP7501000</b>
105.0	100.0	5.6	2.50	GP6501050
105.0	100.0	9.7	2.50	GP6901050
110.0	105.0	9.7	2.50	GP6901100
115.0	110.0	9.7	2.50	GP6901150
120.0	115.0	9.7	2.50	GP6901200
120.0	115.0	15.0	2.50	GP7301200
<b>125.0</b>	<b>120.0</b>	<b>5.6</b>	<b>2.50</b>	<b>GP6501250</b>
<b>125.0</b>	<b>120.0</b>	<b>9.7</b>	<b>2.50</b>	<b>GP6901250</b>

All sizes printed in **bold** type conform to ISO 10766 and should be preferred for use. Additional sizes not covered by this list are also held in stock. Also please note that customer specific sizes can be supplied without tooling costs.



# Orkot<sup>®</sup> Slydring<sup>®</sup> - Wear Ring

Dimensions				TSS Part No.
Bore Diameter	Groove Diameter	Groove Width	Thickness	
<b>D<sub>N</sub></b> H9	<b>d<sub>2</sub></b> h8	<b>L<sub>2</sub></b> +0.2	<b>W</b>	
<b>125.0</b>	<b>120.0</b>	<b>15.0</b>	<b>2.50</b>	<b>GP7301250</b>
<b>125.0</b>	<b>120.0</b>	<b>25.0</b>	<b>2.50</b>	<b>GP7501250</b>
130.0	125.0	9.7	2.50	GP6901300
130.0	125.0	15.0	2.50	GP7301300
135.0	130.0	9.7	2.50	GP6901350
135.0	130.0	15.0	2.50	GP7301350
<b>140.0</b>	<b>135.0</b>	<b>9.7</b>	<b>2.50</b>	<b>GP6901400</b>
<b>140.0</b>	<b>135.0</b>	<b>15.0</b>	<b>2.50</b>	<b>GP7301400</b>
<b>140.0</b>	<b>135.0</b>	<b>25.0</b>	<b>2.50</b>	<b>GP7501400</b>
145.0	140.0	25.0	2.50	GP7501450
150.0	145.0	9.7	2.50	GP6901500
150.0	145.0	15.0	2.50	GP7301500
150.0	145.0	25.0	2.50	GP7501500
<b>160.0</b>	<b>155.0</b>	<b>9.7</b>	<b>2.50</b>	<b>GP6901600</b>
<b>160.0</b>	<b>155.0</b>	<b>15.0</b>	<b>2.50</b>	<b>GP7301600</b>
170.0	165.0	15.0	2.50	GP7301700
175.0	170.0	25.0	2.50	GP7501750
<b>180.0</b>	<b>175.0</b>	<b>9.7</b>	<b>2.50</b>	<b>GP6901800</b>
<b>180.0</b>	<b>175.0</b>	<b>15.0</b>	<b>2.50</b>	<b>GP7301800</b>
180.0	175.0	25.0	2.50	GP7501800
190.0	185.0	9.7	2.50	GP6901900
190.0	185.0	15.0	2.50	GP7301900
<b>200.0</b>	<b>195.0</b>	<b>9.7</b>	<b>2.50</b>	<b>GP6902000</b>
<b>200.0</b>	<b>195.0</b>	<b>15.0</b>	<b>2.50</b>	<b>GP7302000</b>
200.0	195.0	25.0	2.50	GP7502000
205.0	200.0	15.0	2.50	GP7302050
210.0	205.0	15.0	2.50	GP7302100
<b>220.0</b>	<b>215.0</b>	<b>9.7</b>	<b>2.50</b>	<b>GP6902200</b>
<b>220.0</b>	<b>215.0</b>	<b>15.0</b>	<b>2.50</b>	<b>GP7302200</b>
220.0	215.0	25.0	2.50	GP7502200
230.0	225.0	9.7	2.50	GP6902300
230.0	225.0	15.0	2.50	GP7302300
230.0	225.0	25.0	2.50	GP7502300

All sizes printed in **bold** type conform to ISO 10766 and should be preferred for use. Additional sizes not covered by this list are also held in stock. Also please note that customer specific sizes can be supplied without tooling costs.



Dimensions				TSS Part No.
Bore Diameter	Groove Diameter	Groove Width	Thickness	
<b>D<sub>N</sub></b> H9	<b>d<sub>2</sub></b> h8	<b>L<sub>2</sub></b> +0.2	<b>W</b>	
240.0	235.0	9.7	2.50	GP6902400
240.0	235.0	15.0	2.50	GP7302400
240.0	235.0	25.0	2.50	GP7502400
<b>250.0</b>	<b>245.0</b>	<b>9.7</b>	<b>2.50</b>	<b>GP6902500</b>
<b>250.0</b>	<b>245.0</b>	<b>15.0</b>	<b>2.50</b>	<b>GP7302500</b>
250.0	245.0	25.0	2.50	GP7502500
270.0	265.0	25.0	2.50	GP7502600
280.0	275.0	9.7	2.50	GP6902800
<b>280.0</b>	<b>275.0</b>	<b>15.0</b>	<b>2.50</b>	<b>GP7302800</b>
<b>280.0</b>	<b>272.0</b>	<b>25.0</b>	<b>4.00</b>	<b>GP9802800</b>
300.0	295.0	15.0	2.50	GP7303000
300.0	295.0	25.0	2.50	GP7503000
300.0	292.0	25.0	4.00	GP9803000
310.0	302.0	25.0	4.00	GP9803100
<b>320.0</b>	<b>315.0</b>	<b>15.0</b>	<b>2.50</b>	<b>GP7303200</b>
<b>320.0</b>	<b>315.0</b>	<b>25.0</b>	<b>2.50</b>	<b>GP7503200</b>
<b>320.0</b>	<b>312.0</b>	<b>25.0</b>	<b>4.00</b>	<b>GP9803200</b>
340.0	335.0	25.0	2.50	GP7503400
340.0	332.0	25.0	4.00	GP9803400
350.0	345.0	25.0	2.50	GP7503500
<b>360.0</b>	<b>355.0</b>	<b>15.0</b>	<b>2.50</b>	<b>GP7303600</b>
<b>360.0</b>	<b>355.0</b>	<b>25.0</b>	<b>2.50</b>	<b>GP7503600</b>
<b>360.0</b>	<b>352.0</b>	<b>25.0</b>	<b>4.00</b>	<b>GP9803600</b>
<b>400.0</b>	<b>395.0</b>	<b>15.0</b>	<b>2.50</b>	<b>GP7304000</b>
<b>400.0</b>	<b>395.0</b>	<b>25.0</b>	<b>2.50</b>	<b>GP7504000</b>
<b>400.0</b>	<b>392.0</b>	<b>25.0</b>	<b>4.00</b>	<b>GP9804000</b>
420.0	415.0	25.0	2.50	GP7504200
440.0	432.0	25.0	4.00	GP9804400
<b>450.0</b>	<b>445.0</b>	<b>15.0</b>	<b>2.50</b>	<b>GP7304500</b>
<b>450.0</b>	<b>445.0</b>	<b>25.0</b>	<b>2.50</b>	<b>GP7504500</b>
<b>450.0</b>	<b>442.0</b>	<b>25.0</b>	<b>4.00</b>	<b>GP9804500</b>
<b>500.0</b>	<b>495.0</b>	<b>15.0</b>	<b>2.50</b>	<b>GP7305000</b>
<b>500.0</b>	<b>495.0</b>	<b>25.0</b>	<b>2.50</b>	<b>GP7505000</b>

All sizes printed in **bold** type conform to ISO 10766 and should be preferred for use.

Additional sizes not covered by this list are also held in stock. Also please note that customer specific sizes can be supplied without tooling costs.



## Orkot<sup>®</sup> Slydring<sup>®</sup> - Wear Ring

Dimensions				TSS Part No.
Bore Diameter	Groove Diameter	Groove Width	Thickness	
<b>D<sub>N</sub></b> H9	<b>d<sub>2</sub></b> h8	<b>L<sub>2</sub></b> +0.2	<b>W</b>	
<b>500.0</b>	<b>492.0</b>	<b>25.0</b>	<b>4.00</b>	<b>GP9805000</b>
600.0	595.0	25.0	2.50	GP7506000
600.0	592.0	25.0	4.00	GP9806000
700.0	692.0	25.0	4.00	GP9807000
1000.0	995.0	25.0	2.50	GP75X1000
1000.0	992.0	25.0	4.00	GP98X1000
1200.0	1195.0	25.0	2.50	GP75X1200
1500.0	1495.0	25.0	2.50	GP75X1500

All sizes printed in **bold** type conform to ISO 10766 and should be preferred for use.

Additional sizes not covered by this list are also held in stock. Also please note that customer specific sizes can be supplied without tooling costs.





## ■ Installation Recommendation, Orkot® Slydring® for Rod According to ISO 10766 Groove Dimension

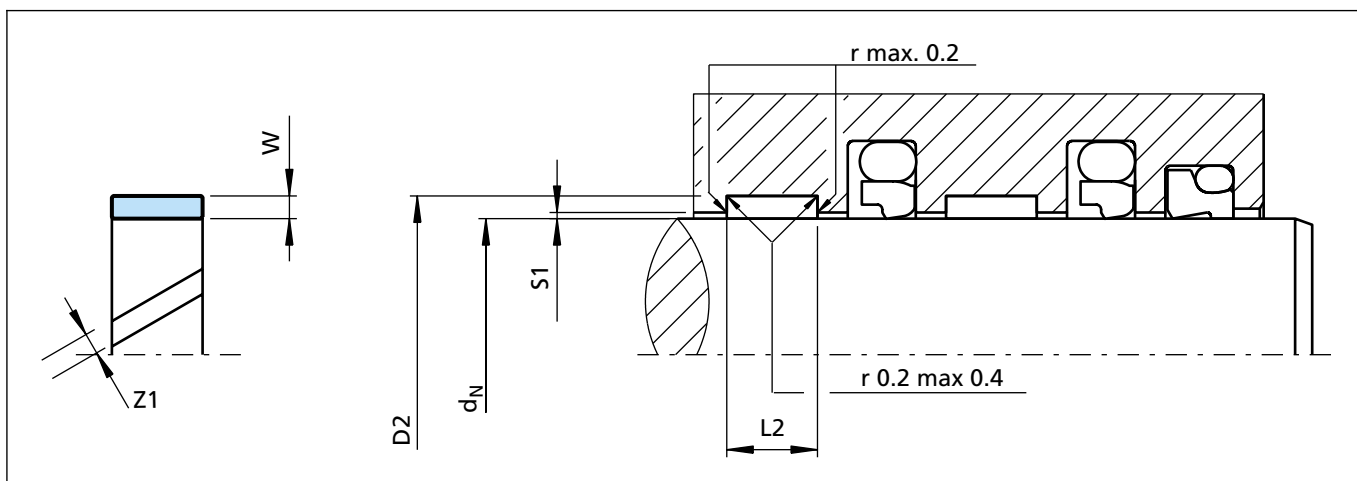

Figure 18 Installation drawing

**Table XLVI Installation Dimensions**

Serial No.	Rod Diameter <sup>1)</sup>	Groove Diameter	Groove Width	Ring Thickness	Ring Gap <sup>2)</sup>
	$d_N$ f8/h9	$D_2$ H8	$L_2$ +0.2	$W$	$Z1$
GR43	8 - 50.0	$d_N$ +3.10	4.00	1.55	1 - 3
GR65	16 - 120.0	$d_N$ +5.00	5.60	2.50	2 - 6
GR69	25 - 250.0	$d_N$ +5.00	9.70	2.50	2 - 9
GR73	75 - 500.0	$d_N$ +5.00	15.00	2.50	4 - 17
GR75	120 - 999.9	$d_N$ +5.00	25.00	2.50	5 - 33
GR75X	1000-1500.0	$d_N$ +5.00	25.00	2.50	33 - 49
GR98	280 - 999.9	$d_N$ +8.00	25.00	4.00	10 - 33
GR98X	1000-1500.0	$d_N$ +8.00	25.00	4.00	33 - 49

<sup>1)</sup> Recommended diameter ranges.

<sup>2)</sup> see figure 19.

For Slydring® to other standards, e.g French standard NF E 48-037, please contact us.

### Radial clearance S1

The minimum radial gap is to be calculated taking into account;

- the fitting tolerances of the hardware
- the tolerance on the ring thickness
- an allowance for wear
- in case of high radial loads an allowance for elastic deformation
- a safety margin to avoid metal-to-metal contact

The gaps S1 can be chosen larger than near to the seal (attention: take care of gap dimension for the seal) thus allowing slight bending of the rod, still without metal-to-metal contact. It also allows foreign particles to be wiped away by the Slydring® rather than being squeezed

between the metal components (see page 12). The slot "Z1" allows fluid to pass across the ring thus preventing fluid pressure build-up which might cause extrusion of the guide ring. To ensure the ring cannot escape out of the groove it is recommended to observe following radial gap sizes as maximum:

- 0.50 mm for GR43 ( 1.55 mm thickness)
- 0.90 mm for GR65 to GR75 ( 2.50 mm thickness)
- 1.50 mm for GR98 and GR98X ( 4.00 mm thickness)



# Orkot<sup>®</sup> Slydring<sup>®</sup> - Wear Ring

**Table XLVII Recommended Radii for Groove Bottom.**

$d_N$	r max.
8 - 250	0.2
> 250	0.4

**Table XLVIII Surface Roughness**

Parameter	Mating Surface $\mu\text{m}$	Groove Surface $\mu\text{m}$
$R_{\text{max}}$	1.00 - 4.00	< 16.0
$R_z$ DIN	0.63 - 2.50	< 10.0
$R_a$	0.10 - 0.40	< 2.5



Figure 19 Recommended Gap Sizes Z1 for Orkot Wear Ring



## Ordering Example

Slydring® for rod diameter  $d_N = 63.0$  mm  
 Series GR 65 from Table XLVI  
 Groove width: 5.6 mm, ring thickness: 2.50 mm

Material: Orkot® C380  
 (other materials see Table I)

Standard design: With angle cut  
 Design code: 0

TSS Part No.: GR6500630  
 (from Table XLIX)

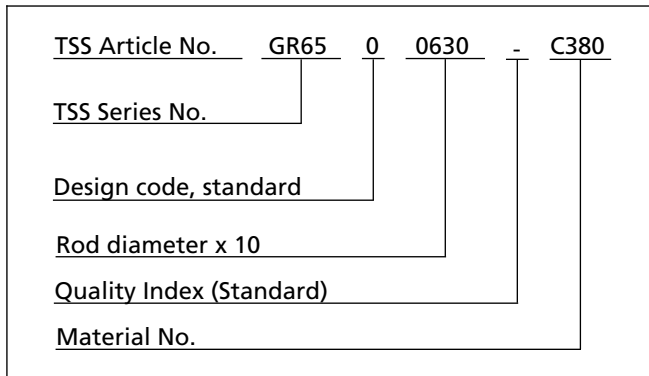

## Ordering Example

Slydring® for rod diameter  $d_N = 63.0$  mm  
 Series GR 69 from Table XLVI  
 Groove width: 9.7 mm, ring thickness: 2.50 mm

Material: Orkot® C380

Standard design: With angle cut  
 Design code: 0

TSS Part No.: GR6900630  
 (from Table XLIX)

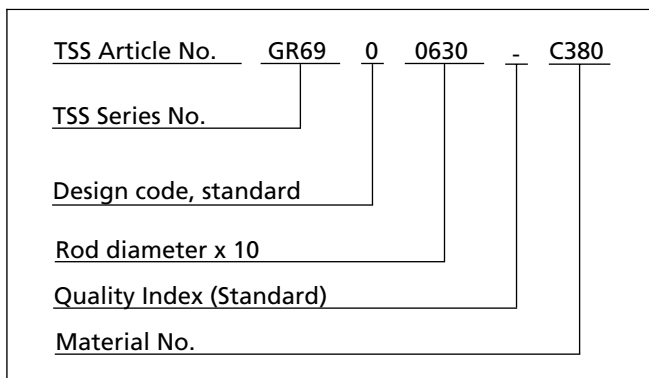

## Ordering Example for diameter >1000 mm

Slydring® for rod diameter  $d_N = 1200.0$  mm  
 Series GR 75X from Table XLVI  
 Groove width: 25.0 mm, ring thickness: 2.50 mm

Material: Orkot® C380

TSS Part No.: GR75X1200  
 (from Table XLIX)

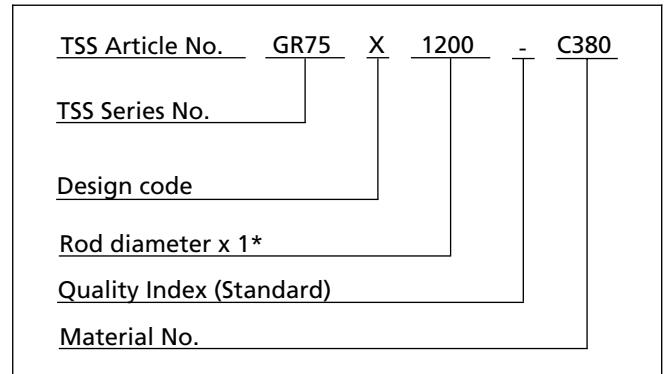

\* For diameters  $\geq 1000.0$  mm multiply only by factor 1.

## Please Note

Orkot® Slydring® for rods can be used as piston guide ring, f.inst.

### GR65 0 0630 - C380

is identical and can be replaced with

### GP65 0 0680 - C380



# Orkot<sup>®</sup> Slydring<sup>®</sup> - Wear Ring

Table XLIX Slydring<sup>®</sup> for Rods

Dimensions				TSS Part No.
Rod Diameter	Groove Diameter	Groove Width	Thickness	
$d_N$ f8/h9	$D_2$ H8	$L_2$ +0.2	$W$	
11.0	14.1	4.0	1.55	GR4300110
15.0	18.1	4.0	1.55	GR4300150
16.0	21.0	5.6	2.50	GR6500160
18.0	23.0	5.6	2.50	GR6500180
20.0	25.0	5.6	2.50	GR6500200
20.0	25.0	9.7	2.50	GR6900200
22.0	27.0	5.6	2.50	GR6500220
<b>25.0</b>	<b>30.0</b>	<b>5.6</b>	<b>2.50</b>	<b>GR6500250</b>
25.0	30.0	9.7	2.50	GR6900250
27.0	32.0	9.7	2.50	GR6900270
<b>28.0</b>	<b>31.1</b>	<b>4.0</b>	<b>1.55</b>	<b>GR4300280</b>
<b>28.0</b>	<b>33.0</b>	<b>5.6</b>	<b>2.50</b>	<b>GR6500280</b>
28.0	33.0	9.7	2.50	GR6900280
30.0	35.0	5.6	2.50	GR6500300
30.0	35.0	9.7	2.50	GR6900300
<b>32.0</b>	<b>37.0</b>	<b>5.6</b>	<b>2.50</b>	<b>GR6500320</b>
<b>32.0</b>	<b>37.0</b>	<b>9.7</b>	<b>2.50</b>	<b>GR6900320</b>
35.0	40.0	9.7	2.50	GR6900350
<b>36.0</b>	<b>41.0</b>	<b>5.6</b>	<b>2.50</b>	<b>GR6500360</b>
<b>36.0</b>	<b>41.0</b>	<b>9.7</b>	<b>2.50</b>	<b>GR6900360</b>
36.0	41.0	15.0	2.50	GR7300360
<b>40.0</b>	<b>45.0</b>	<b>5.6</b>	<b>2.50</b>	<b>GR6500400</b>
<b>40.0</b>	<b>45.0</b>	<b>9.7</b>	<b>2.50</b>	<b>GR6900400</b>
40.0	45.0	15.0	2.50	GR7300400
<b>40.0</b>	<b>45.0</b>	<b>25.0</b>	<b>2.50</b>	<b>GR7500400</b>
42.0	47.0	5.6	2.50	GR6500420
43.0	48.0	5.6	2.50	GR6500430
<b>45.0</b>	<b>50.0</b>	<b>5.6</b>	<b>2.50</b>	<b>GR6500450</b>
<b>45.0</b>	<b>50.0</b>	<b>9.7</b>	<b>2.50</b>	<b>GR6900450</b>
45.0	50.0	15.0	2.50	GR7300450
48.0	53.0	5.6	2.50	GR6500480
48.0	53.0	9.7	2.50	GR6900480
<b>50.0</b>	<b>55.0</b>	<b>5.6</b>	<b>2.50</b>	<b>GR6500500</b>

All sizes printed in **bold** type conform to ISO 10766 and should be preferred for use.

Additional sizes not covered by this list are also held in stock. Also please note that customer specific sizes can be supplied without tooling costs.



Dimensions				TSS Part No.
Rod Diameter	Groove Diameter	Groove Width	Thickness	
$d_N$ f8/h9	$D_2$ H8	$L_2$ +0.2	$W$	
<b>50.0</b>	<b>55.0</b>	<b>9.7</b>	<b>2.50</b>	<b>GR6900500</b>
50.0	55.0	15.0	2.50	GR7300500
52.0	57.0	5.6	2.50	GR6500520
52.0	57.0	9.7	2.50	GR6900520
55.0	60.0	9.7	2.50	GR6900550
55.0	60.0	15.0	2.50	GR7300550
55.0	60.0	25.0	2.50	GR7500550
<b>56.0</b>	<b>61.0</b>	<b>5.6</b>	<b>2.50</b>	<b>GR6500560</b>
<b>56.0</b>	<b>61.0</b>	<b>9.7</b>	<b>2.50</b>	<b>GR6900560</b>
<b>56.0</b>	<b>61.0</b>	<b>15.0</b>	<b>2.50</b>	<b>GR7300560</b>
58.0	63.0	5.6	2.50	GR6500580
58.0	63.0	9.7	2.50	GR6900580
60.0	65.0	5.6	2.50	GR6500600
60.0	65.0	9.7	2.50	GR6900600
60.0	65.0	15.0	2.50	GR7300600
60.0	65.0	25.0	2.50	GR7500600
<b>63.0</b>	<b>68.0</b>	<b>9.7</b>	<b>2.50</b>	<b>GR6900630</b>
63.0	68.0	15.0	2.50	GR7300630
65.0	70.0	5.6	2.50	GR6500650
65.0	70.0	9.7	2.50	GR6900650
65.0	70.0	15.0	2.50	GR7300650
<b>70.0</b>	<b>75.0</b>	<b>5.6</b>	<b>2.50</b>	<b>GR6500700</b>
<b>70.0</b>	<b>75.0</b>	<b>9.7</b>	<b>2.50</b>	<b>GR6900700</b>
70.0	75.0	15.0	2.50	GR7300700
<b>70.0</b>	<b>75.0</b>	<b>25.0</b>	<b>2.50</b>	<b>GR7500700</b>
75.0	80.0	5.6	2.50	GR6500750
75.0	80.0	9.7	2.50	GR6900750
75.0	80.0	15.0	2.50	GR7300750
80.0	85.0	5.6	2.50	GR6500800
<b>80.0</b>	<b>85.0</b>	<b>9.7</b>	<b>2.50</b>	<b>GR6900800</b>
<b>80.0</b>	<b>85.0</b>	<b>15.0</b>	<b>2.50</b>	<b>GR7300800</b>
<b>80.0</b>	<b>85.0</b>	<b>25.0</b>	<b>2.50</b>	<b>GR7500800</b>
85.0	90.0	9.7	2.50	GR6900850

All sizes printed in **bold** type conform to ISO 10766 and should be preferred for use.

Additional sizes not covered by this list are also held in stock. Also please note that customer specific sizes can be supplied without tooling costs.



# Orkot<sup>®</sup> Slydring<sup>®</sup> - Wear Ring

Dimensions				TSS Part No.
Rod Diameter	Groove Diameter	Groove Width	Thickness	
$d_N$ f8/h9	$D_2$ H8	$L_2$ +0.2	$W$	
85.0	90.0	15.0	2.50	GR7300850
90.0	95.0	5.6	2.50	GR6500900
<b>90.0</b>	<b>95.0</b>	<b>9.7</b>	<b>2.50</b>	<b>GR6900900</b>
<b>90.0</b>	<b>95.0</b>	<b>15.0</b>	<b>2.50</b>	<b>GR7300900</b>
90.0	95.0	25.0	2.50	GR7500900
95.0	100.0	5.6	2.50	GR6500950
95.0	100.0	9.7	2.50	GR6900950
95.0	100.0	15.0	2.50	GR7300950
100.0	105.0	5.6	2.50	GR6501000
<b>100.0</b>	<b>105.0</b>	<b>9.7</b>	<b>2.50</b>	<b>GR6901000</b>
<b>100.0</b>	<b>105.0</b>	<b>15.0</b>	<b>2.50</b>	<b>GR7301000</b>
100.0	105.0	25.0	2.50	GR7501000
105.0	110.0	15.0	2.50	GR7301050
105.0	110.0	25.0	2.50	GR7501050
<b>110.0</b>	<b>115.0</b>	<b>9.7</b>	<b>2.50</b>	<b>GR6901100</b>
<b>110.0</b>	<b>115.0</b>	<b>15.0</b>	<b>2.50</b>	<b>GR7301100</b>
110.0	115.0	25.0	2.50	GR7501100
115.0	120.0	9.7	2.50	GR6901150
115.0	120.0	15.0	2.50	GR7301150
120.0	125.0	15.0	2.50	GR7301200
<b>125.0</b>	<b>130.0</b>	<b>15.0</b>	<b>2.50</b>	<b>GR7301250</b>
125.0	130.0	25.0	2.50	GR7501250
130.0	135.0	15.0	2.50	GR7301300
<b>140.0</b>	<b>145.0</b>	<b>9.7</b>	<b>2.50</b>	<b>GR6901400</b>
<b>140.0</b>	<b>145.0</b>	<b>15.0</b>	<b>2.50</b>	<b>GR7301400</b>
140.0	145.0	25.0	2.50	GR7501400
150.0	155.0	15.0	2.50	GR7301500
150.0	155.0	25.0	2.50	GR7501500
155.0	160.0	15.0	2.50	GR7301550
155.0	160.0	25.0	2.50	GR7501550
<b>160.0</b>	<b>165.0</b>	<b>9.7</b>	<b>2.50</b>	<b>GR6901600</b>
<b>160.0</b>	<b>165.0</b>	<b>15.0</b>	<b>2.50</b>	<b>GR7301600</b>
<b>160.0</b>	<b>165.0</b>	<b>25.0</b>	<b>2.50</b>	<b>GR7501600</b>

All sizes printed in **bold** type conform to ISO 10766 and should be preferred for use. Additional sizes not covered by this list are also held in stock. Also please note that customer specific sizes can be supplied without tooling costs.



Dimensions				TSS Part No.
Rod Diameter	Groove Diameter	Groove Width	Thickness	
$d_N$ f8/h9	$D_2$ H8	$L_2$ +0.2	<b>W</b>	
170.0	175.0	15.0	2.50	GR7301700
170.0	175.0	25.0	2.50	GR7501700
<b>180.0</b>	<b>185.0</b>	<b>15.0</b>	<b>2.50</b>	<b>GR7301800</b>
190.0	195.0	15.0	2.50	GR7301900
190.0	195.0	25.0	2.50	GR7501900
<b>200.0</b>	<b>205.0</b>	<b>15.0</b>	<b>2.50</b>	<b>GR7302000</b>
<b>200.0</b>	<b>205.0</b>	<b>25.0</b>	<b>2.50</b>	<b>GR7502000</b>
<b>200.0</b>	<b>208.0</b>	<b>25.0</b>	<b>4.00</b>	<b>GR9802000</b>
210.0	215.0	15.0	2.50	GR7302100
<b>220.0</b>	<b>225.0</b>	<b>15.0</b>	<b>2.50</b>	<b>GR7302200</b>
<b>220.0</b>	<b>225.0</b>	<b>25.0</b>	<b>2.50</b>	<b>GR7502200</b>
230.0	235.0	25.0	2.50	GR7502300
240.0	245.0	25.0	2.50	GR7502400
240.0	248.0	25.0	4.00	GR9802400
<b>250.0</b>	<b>255.0</b>	<b>25.0</b>	<b>2.50</b>	<b>GR7502500</b>
270.0	275.0	15.0	2.50	GR7302700
<b>280.0</b>	<b>285.0</b>	<b>15.0</b>	<b>2.50</b>	<b>GR7302800</b>
<b>280.0</b>	<b>285.0</b>	<b>25.0</b>	<b>2.50</b>	<b>GR7502800</b>
<b>280.0</b>	<b>288.0</b>	<b>25.0</b>	<b>4.00</b>	<b>GR9802800</b>
300.0	305.0	25.0	2.50	GR7503000
<b>320.0</b>	<b>325.0</b>	<b>25.0</b>	<b>2.50</b>	<b>GR7503200</b>
<b>320.0</b>	<b>328.0</b>	<b>25.0</b>	<b>4.00</b>	<b>GR9803200</b>
350.0	355.0	25.0	2.50	GR7503500
<b>360.0</b>	<b>365.0</b>	<b>25.0</b>	<b>2.50</b>	<b>GR7503600</b>
<b>360.0</b>	<b>368.0</b>	<b>25.0</b>	<b>4.00</b>	<b>GR9803600</b>
400.0	405.0	25.0	2.50	GR7504000
400.0	408.0	25.0	4.00	GR9804000
800.0	805.0	25.0	2.50	GR7508000
800.0	808.0	25.0	4.00	GR9808000
1000.0	1005.0	25.0	2.50	GR75X1000
1000.0	1008.0	25.0	4.00	GR98X1000
1200.0	1205.0	25.0	2.50	GR75X1200
1500.0	1505.0	25.0	2.50	GR75X1500

All sizes printed in **bold** type conform to ISO 10766 and should be preferred for use. Additional sizes not covered by this list are also held in stock. Also please note that customer specific sizes can be supplied without tooling costs.



## Orkot<sup>®</sup> Slydring<sup>®</sup> - Wear Ring

---













**For further information:**

<b>Europe</b>	<b>Telephone</b>	<b>America</b>	<b>Telephone</b>
<b>AUSTRIA - Vienna</b> (ALBANIA, BOSNIA AND HERZEGOVINA, CROATIA, HUNGARY, MACEDONIA, SERBIA AND MONTENEGRO, SLOVENIA)	+43 (1) 406 47 33	<b>AMERICAS - Fort Wayne, IN</b>	+1 (260) 749 9631
<b>BELGIUM - Dion-Valmont</b> (LUXEMBOURG)	+32 (10) 22 57 50	<b>BRAZIL - Sao Paulo</b>	+55 (11) 3372 4500
<b>BULGARIA - Sofia</b> (ROMANIA, RUSSIA)	+359 2 96 99 510	<b>CANADA - Ontario</b>	+1 (416) 213 9444
<b>CZECH REPUBLIC - Rakovnik</b> (SLOVAKIA)	+420 313 529 111	<b>MEXICO - Mexico D.F.</b>	+52 55 57 19 50 05
<b>DENMARK - Hillerød</b>	+45 4822 8080	<b>USA, East - Philadelphia, PA</b>	+1 (610) 828 3209
<b>FINLAND - Vantaa</b> (ESTONIA, LATVIA, LITHUANIA)	+358 (0)9 8256 110	<b>USA, Great Lakes - Fort Wayne, IN</b>	+1 (260) 749 6781
<b>FRANCE - Maisons-Laffitte</b>	+33 (0)1 30 86 56 00	<b>USA, Midwest - Lombard, IL</b>	+1 (630) 268 9915
<b>GERMANY - Stuttgart</b>	+49 (711) 7 86 40	<b>USA, Mountain - Broomfield, CO</b>	+1 (303) 469 1357
<b>GREECE</b>	+41 (21) 6314111	<b>USA, Northwest - Portland, OR</b>	+1 (503) 595 6565
<b>ITALY - Livorno</b>	+39 (0586) 22 61 11	<b>USA, South - N. Charleston, SC</b>	+1 (843) 747 7656
<b>THE NETHERLANDS - Barendrecht</b>	+31 (10) 29 22 111	<b>USA, Southwest - Houston, TX</b>	+1 (713) 461 3495
<b>NORWAY - Oslo</b>	+47 22 64 60 80	<b>USA, West - Torrance, CA</b>	+1 (310) 371 1025
<b>POLAND - Warsaw</b>	+48 (22) 8 63 30 11		
<b>SPAIN - Madrid</b> (PORTUGAL)	+34 91 710 5730	<b>Asia</b>	<b>Telephone</b>
<b>SWEDEN - Jönköping</b>	+46 (36) 34 15 00	<b>ASIA PACIFIC REGIONAL</b>	+65 (6)265 6883
<b>SWITZERLAND - Crissier</b>	+41 (21) 631 41 11	<b>CHINA - Hong Kong</b>	+852 (2)366 9165
<b>TURKEY</b>	+41 (21) 6314111	<b>INDIA - Bangalore</b>	+91 (80) 2655 5157
<b>UNITED KINGDOM - Solihull</b> (EIRE)	+44 (0)121 744 1221	<b>JAPAN - Tokyo</b>	+81 (3) 5633 8008
		<b>KOREA - Gyunggi-Do</b>	+82 (31) 386 3283
		<b>MALAYSIA - Kuala Lumpur</b>	+60 (0) 3 9059 6388
		<b>TAIWAN - Taichung</b>	+886 (4) 23 58 00 82
		<b>THAILAND - Bangkok</b>	+66 (0) 2732-2861
		<b>SINGAPORE</b>	
		<b>and all other countries in Asia</b>	+65 (6)293 2500
<b>AFRICA REGIONAL</b>	+41 (21) 6314111		
<b>MIDDLE EAST REGIONAL</b>	+41 (21) 6314111		

[www.tss.trelleborg.com](http://www.tss.trelleborg.com)

